



Request for Bids to Provide Electrical Construction on the West Young Road Development Project

Project No. 7080

Advertised..... August 15, 2025
 Virtual Pre-Bid Meeting..... 1:00 p.m., August 19, 2025
 Site Visits completed prior to August 25, 2025
 Deadline for questions or clarification 4:00 p.m., August 25, 2025
 Bids due..... 1:30 p.m., August 29, 2025
 Potential award timeframe..... September 2025

Project Manager

Chad Bellenie, Environmental Project Manager

Board of Trustees

Susan Tilgner, Chair
 Commissioner Erica Crawley
 Ron Grossman
 Patrick King
 Jennie McAdams
 Stephen Sayre
 Randy Sokol
 Kenneth N. Wilson

Executive Director

Joseph A. Lombardi

Administration Office

4239 London Groveport Road
 Grove City, Ohio 43123

Telephone: (614) 871-5100
 Fax: (614) 871-5103
 E-Mail: procurement@swaco.org

Request for Bids for Electrical Construction for the West Young Road Development Project



Table of Contents

- 001. Public Notice
- 002. Request for Bids
 - I. General Information
 - A. SWACO
 - B. Board of Trustees
 - II. The Project
 - A. Description
 - B. Objective
 - C. Project Information
 - D. Required Forms and Documents
 - E. Exceptions to RFB
 - F. Sample Contract
 - G. Project Documents
 - H. Times
 - I. Site Visits
 - J. Timeline of Events
 - K. Definitions
 - III. Bid Format and Requirements
 - A. Bid Format
 - B. Bid Requirements
 - C. Bid Preparation Costs
 - D. Required Forms and Documents
 - IV. Submitting the Bid
 - A. Electronic Upload
 - B. Bid Submission
 - C. Bid Documents
 - V. Bid Questions, Modifications, Withdrawal, and Opening
 - A. Bidder Requests for Information and Addendums
 - B. Modification of Bids
 - C. Withdrawal of Bid
 - D. Rejection or Waiver of Bids
 - E. Bid Opening
 - F. Termination of RFB Process
 - VI. Standard Terms and Conditions
 - A. Budgeting
 - B. Taxes and Payment
 - C. Contract Termination
 - D. Pricing
 - E. Invoicing
 - F. Additional Fees
 - G. Indemnification and Insurance
 - VII. Applicable Law
 - A. Venue
 - B. Non-Discrimination
 - C. Public Records
 - D. Prevailing Wages

Table of Contents (*Continued*)

- 002. Request for Bids (*Continued*)
 - VIII. Bid Award
 - A. Award Basis
 - B. Lowest and Best
 - C. Notice of Award
 - IX. Awarding the Contract
 - A. Information Provided to Successful Bidder
 - B. Contract Execution
- 003. Exhibit A – Scope of Bid / Additional Information
- 004. Exhibit B – Required Forms and Documents
 - I. Required Forms
 - a) Bid with Bid Sheet and Bidder's Representative
 - b) Non-Collusion Affidavit
 - c) Non-Discrimination Affidavit
 - d) Affidavit of Authority
 - e) Delinquent Tax Affidavit
 - f) W-9 Form (*Rev. March 2024 by the IRS*)
 - g) Addendum Acknowledgement
 - h) RFB Exceptions
 - i) Acknowledgement (Local, Certified, EOE, and Green)
 - II. Required Documents from Bidder
 - a) Bidder's Statement
 - b) Bid Guaranty for Bid Bond
 - c) Consent of Surety for Payment Bond
- 005. Exhibit C – Sample Contract and Contract Forms
 - I. Sample Contract
 - II. Contract Forms
 - A. Supplementary Conditions
 - B. Notice of Award
 - C. Notice to Proceed
 - D. Notice of Commencement of Public Improvement
 - E. Field Work Order
 - F. Change Order
 - G. Certificate of Substantial Completion
 - H. Partial Release and Waiver of Lien
 - I. Final Release and Waiver of Lien
 - J. Release of Lien
- 006. Exhibit D – SWACO General Conditions for Construction
- 007. Exhibit E – Specifications
- 008. Exhibit F – Drawings
- 009. Exhibit G – Prevailing Wage Rates



Public Notice

The Solid Waste Authority of Central Ohio (SWACO) is inviting sealed bids from qualified suppliers to provide Electrical Construction for the West Young Road Development Project. Site visits are optional and must be scheduled by appointment before August 25, 2025. A virtual pre-bid meeting is scheduled for 1:00 p.m., August 19, 2025. Do Business With Us and register to download the RFB documents by visiting www.swaco.org/Bids.aspx. Bids for this Project must be received by SWACO no later than 1:30 p.m. (EST) August 29, 2025. Contact SWACO Procurement in writing only at procurement@swaco.org for questions concerning this RFB. No phone calls please. SWACO reserves the right to reject any and all Bids and to waive minor irregularities or informalities in the selection process.

Advertised in *The Columbus Dispatch* on Friday, August 15, 2025.

I. General Information

A. SWACO. The Solid Waste Authority of Central Ohio (“SWACO”) is a regional solid waste authority established in accordance with Ohio Revised Code Section 343.011. SWACO was created in 1989 in response to Substitute House Bill 592 (“HB 592”) to develop and implement a comprehensive solid waste management plan for the Franklin County Solid Waste Management District, which is comprised principally of Franklin County but includes parts of five (5) adjacent counties (collectively the “District”).

As a political subdivision of the State of Ohio, SWACO operates a Subtitle D sanitary landfill with an allowable maximum daily capacity of eight thousand (8,000) tons and two (2) waste transfer stations with a combined capacity of approximately two thousand (2,000) tons per day. SWACO owns and/or leases multiple facilities and operates on an estimated fifty-one million dollars (\$51,000,000) of annual revenue and twenty-five million (\$25,000,000) of SWACO’s EPA Trust Fund.

SWACO employs approximately one hundred thirty-five (135) full-time staff who work under four (4) major organizational functions: Administration, Operations, Legal Affairs, and Innovation & Programs. SWACO also provides programs aimed at reducing the generation and disposal of solid waste within SWACO’s District. These programs include public education and awareness, yard waste composting, and other waste-reduction activities. SWACO is also responsible for maintenance activities at a closed landfill. Total solid waste generation within SWACO’s District exceeds one million tons (1,000,000) per year.

B. Board of Trustees. A nine (9)-member Board of Trustees (“Board”) governs SWACO. Pursuant to Ohio Revised Code Section 343.011 and SWACO’s bylaws, the Mayor of the City of Columbus and the Franklin County Board of Commissioners each appoint two (2) members to the Board. Other members include one (1) designee of the Franklin County Health Commissioner, one (1) designee of Franklin County’s Township Trustees, and three (3) members appointed by the Board representing the public, general interest of the citizens, and the industrial, commercial, or institutional generators of solid wastes within the District. The Board appoints SWACO’s Executive Director, who serves to direct the daily operations and functions of SWACO as SWACO’s Chief Executive Officer.

II. The Project

A. Project Description. This Project generally encompasses installing a new 480Y/277V, 400A, three- (3)-phase power service from existing AEP overhead three-(3)-phase service. This new service shall accommodate the installation of a seventy-five (75) horsepower dewatering pump and VFD, six (6) power receptacle pedestals, two (2) overhead utility lights, and a security camera. Service conductors will run underground from the AEP service pole to a new service equipment rack.

B. Project Objective. SWACO is seeking qualified Bidders that can complete the Project as described in the RFB Documents.

C. Project Information. Additional information, attached hereto as *Exhibit A* and made part of this RFB, provides additional information relating to the Successful Bidder and the Project.

D. Required Forms and Documents. Section III, Subsection C, provides a list of Required Forms, attached hereto as **Exhibit B**, and a list of Required Documents to be provided by Bidder for this RFB.

1. All Required Forms (Exhibit B) are to be filled out in their entirety, notarized where applicable, and included with the Bid submission. Please be sure to include any needed documentation for the *Acknowledgment* form.

2. Bidder must also provide a *Bidder's Statement*, *Bid Guaranty*, and *Consent of Surety* (as applicable) with their Bid submission. Section III, Subsection C, provides an explanation for each document.

3. Bids must be submitted on the Bid Sheet provided in **Exhibit B**. A spreadsheet of the Bid Tab is available for download as a separate attachment for Bidders to use.

E. Exceptions to RFB. Any exceptions to this RFB will be considered and included in SWACO's analysis. If the Bidder fails to list any exceptions, SWACO will assume compliance with the terms, conditions, and requirements of the RFB, including the Sample Contract, and Bidder shall not raise any exceptions later if selected for award. Please see Exhibit B, Required Forms and Documents, for the *RFB Exceptions* Form.

F. Sample Contract. A sample contract is provided, attached hereto as **Exhibit C**, setting forth the proposed terms, conditions, provisions and/or specifications, which shall govern the relationship of SWACO and the Successful Bidder, if any, upon the award of a contract for the Project.

G. Project Documents. Documents that may also be included with the Contract are SWACO's General Conditions, attached hereto as **Exhibit D**, Specifications, attached hereto as **Exhibit E**, Construction Plans attached hereto as **Exhibit F**, and Prevailing Wages, attached hereto as **Exhibit G**.

H. Times. All times set forth in this RFB are listed at Grove City, Ohio local time, which is Eastern Standard Time (EST).

I. Virtual Pre-Bid Meeting. A virtual pre-bid meeting is scheduled for 1:00 p.m. (EST), August 19, 2025. **All Bidders are required to attend the pre-bid meeting.** Those attending must sign in with your name and company to be validated as attending. Please see the information below to attend the pre-bid meeting either virtually or in person.

Pre-Bid Meeting | RFB Electrical Construction for WYR Development
August 19, 2025 at 1:00 p.m. (EST)

Microsoft Teams

[Join the meeting now](#)

Meeting ID: 244 315 097 412 2

Passcode: tD75HF6u

Dial in by phone

[+1 513-301-2202,393166339#](#) United States, Cincinnati

[Find a local number](#)

Phone conference ID: 393 166 339#

For organizers: [Meeting options](#) | [Reset dial-in PIN](#)

J. Site Visits. Bidders can request a site visit by contacting Mr. Chad Bellenie. Site visits are encouraged and can be coordinated by emailing Mr. Bellenie at chad.bellenie@swaco.org prior to August 25, 2025. All visits must be completed prior to August 25, 2025.

K. Timeline of Events. The Public Notice for this Project was posted on August 15, 2025. Bid Documents are available on SWACO’s website (www.swaco.org/Bids.aspx) through 1:30 p.m., August 29, 2025. Dates listed below show the timeline of this RFB. Deadlines for pre-bid meetings, site visits, questions, when bids are due, and awards are shown. Please note that all dates listed below may be altered at SWACO's sole and complete discretion.

Advertised.....	August 15, 2025
Virtual Pre-Bid Meeting	1:00 p.m., August 19, 2025
Site Visits	completed prior to August 25, 2025
Deadline for questions or clarification.....	4:00 p.m., August 25, 2025
Bids due	1:30 p.m., August 29, 2025
Potential award timeframe	September 2025

L. Definitions. For purposes of this RFB, the words, terms, and phrases set forth below shall have the indicated meanings. Any other terms, words, or phrases herein shall have their ordinary meaning.

1. *Bid* means the written response to this RFB, including, without limitation, any modifications or revisions thereto, submitted pursuant to the terms, conditions and provisions set forth in this RFB.
2. *Bid Documents* means this RFB, the Proposed Contract, Exhibits, any addenda or documents issued by SWACO after release of this RFB but before the Bid due date.
3. *Bidder* means any vendor that submits a Bid.
4. *FCSL* means the Franklin County Sanitary Landfill located at 4200 London Groveport Road, Grove City.
5. *JPTS* means the Jackson Pike Transfer Station located at 2566 Jackson Pike, Columbus.
6. *Project* means providing all necessary labor, equipment, tools, and materials required to provide the Project as described in the RFB Documents.
7. *RFB* means this Request For Bids.
8. *Sample Contract* means the sample contract provided by SWACO to potential Bidders setting forth the proposed terms, conditions, provisions and/or specifications which may govern the relationship of SWACO and the Successful Bidder, if any, upon award of the contract for the Project.
9. *Successful Bidder* means the Bidder submitting the lowest and best responsive bid as determined by SWACO in its sole and complete discretion.
10. *SWACO* means the Solid Waste Authority of Central Ohio.

III. Bid Format and Requirements

A. Bid Format. All Bids must be electronically uploaded to SWACO using the link and instructions provided in Section IV below.

B. Bid Requirements. All Bids should be assembled in sequential order of the requested information in this Section III and shall be submitted in such a manner as to facilitate the review of the content contained therein.

1. All prospective Bidders must be able to show at least three (3) client references demonstrating experience performing similar projects within the past ten (10) years of similar size and scope of work. All Bidders should be prepared to show proof of such experience upon request. Failure to provide documentation will result in disqualification from the bidding process.

2. Bidders must submit a proposed construction schedule with their Bid for the Project.

3. **Bids must be submitted using the Bid Sheet contained in Exhibit B, along with the *Required Forms and Documents*.**

4. Bidders must disclose any employees who were previously employed at SWACO within the last two (2) years**.

**For every employee disclosed, please provide the date he/she was hired, a detailed explanation as to how the Bidder will prevent the employee from participating in this Project, and an affirmation from the employee that he/she will not disclose confidential information acquired in the course of his/her employment with SWACO.

C. Bid Preparation Costs. All costs of preparing and submitting a Bid pursuant to the Bid Documents shall be the sole and complete responsibility of the Bidder.

D. Required Forms and Documents. Each Bid must contain the following:

1. Required Forms, attached hereto as *Exhibit B*, must be filled out in their entirety, fully executed, and included with the Bid:

- a) Bid Sheet and Bidder's Representative
- b) Non-Collusion Affidavit
- c) Non-Discrimination Affidavit
- d) Affidavit of Authority
- e) Delinquent Tax Affidavit
- f) W-9 Form (*Rev. March 2024 by the IRS*)
- g) Addendum Acknowledgment
- h) Exceptions to RFB
- i) Acknowledgement (Local, Certified, EOE, and Green)

2. Bidders must also include with their Bid the following required documents:

- a) Bidder's Statement – The Bidder's Statement must provide evidence that will enable SWACO to judge the responsibility, experience, skill, and financial standing of Bidder by including detailed information to the effect that Bidder maintains a permanent place of business, statements as to its present physical condition, and evidence to the fact that Bidder has a suitable financial status to meet the obligations to furnish the equipment, materials, and labor referenced in the bid package for purchase by SWACO.
- b) Bid Guarantee – The Bid Guaranty is surety that if a Bid is accepted, the Bid price will be honored in the contract.

- i. A Bid Guarantee is to be provided by the Bidder stating that a Bid Bond can be acquired if the Project is awarded to them. A Bid Bond pursuant to Ohio Revised Code 153.571 in which the bond guarantees the Bid price.
 - ii. The Bid Guarantee can be in the form of: (i) a bond equal to one hundred percent (100%) of the Bid price; or, (ii) a certified check, cashier's check or letter of credit pursuant to Chapter 1305 of the Ohio Revised Code on a solvent bank note equal to ten percent (10%) of the Bid price.
- c) Consent of Surety – A Consent of Surety is to be provided by the Bidder stating that a Payment Bond can be acquired if the Project is awarded to them. A Payment Bond guarantees the Successful Bidder's payment of all persons and/or organizations providing labor and/or materials in the prosecution of the Services as set forth in the RFB Documents. Such payment bond shall be equal to one hundred percent (100%) of the contract price.

IV. Submitting the Bid

A. Electronic Upload. All Bids must be uploaded electronically in PDF format and titled, "**Bidder's Name – Electric Construction**". ZIP FILES WILL NOT BE ACCEPTED. Please include Bidder's name with the file name and upload to the following link:

<https://swaco.sharefile.com/r-rbb64a0365e5e46cba3960173dbed7a05>

Click on the link above, which will take you to another screen to enter your email, name, and company before the link opens for you to submit your Bid.

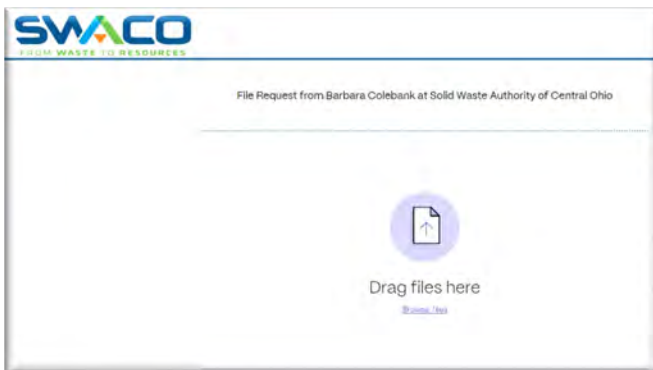

← Next, drag and drop your documents into the ShareFile box.

Please Note: A successful upload will display as shown to the right ➡.

You will not receive additional confirmation of your document upload.

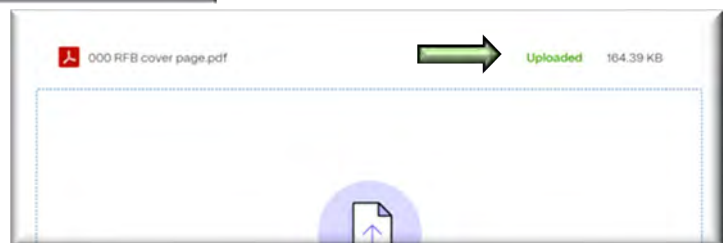

Do not email your Bid if you are having problems uploading your document(s). If you are not able to upload the Bid documents to the link above, please contact Barbara Colebank at barbara.colebank@swaco.org.

B. Bid Submission. It is the sole responsibility of the Bidder for the electronic upload of its Bid prior to 1:30 p.m., August 29, 2025.

1. The submission of a Bid shall be considered evidence that the Bidder has examined and is satisfied as to the terms, conditions, provisions, specifications and/or requirements for the Project described in the Bid Documents.
2. No pleas of ignorance of any of the terms, conditions, provisions and/or specifications set forth in the Bid Documents shall be accepted as a basis for any claim for an increase in the amount bid by a Bidder or an extension of the times set forth in the Bid Documents.
3. Unless otherwise specified in the Bid Documents, the Bid price(s) shall include all applicable federal, state, and local taxes. The Successful Bidder shall pay all taxes lawfully imposed on it with respect to any product or service delivered in accordance with the Bid Documents and/or any contract awarded as a result of the process set forth in the Bid Documents.
4. Failure to submit the Bid electronically to the link in Paragraph A above shall not be considered as a valid submission to SWACO.
5. Bids submitted by facsimile transmission, e-mail, or in any other form not specified herein shall not be accepted by SWACO.

C. Bid Documents. As appropriate, the Bid Documents must be signed by the individual, by one (1) or more members of the partnership, by one (1) or more members or officers of each firm representing a joint venture, or by one (1) or more officers of a corporation, or by an agent of the Bidder legally qualified and acceptable to SWACO.

1. If the Bid is made by an individual, his or her name, and business address must be set forth in the Bid;
2. If the Bid is made by a partnership, the name and business address of each partnership member must be indicated in the Bid;
3. If the Bid is made as a joint venture, the name and business address of each member or officer of the firms represented by the joint venture must be indicated in the Bid;
4. If the Bid is made by a corporation, the name of the state under the laws of which the corporation is chartered and the name and title of the officer or officers having authority under the bylaws to sign contracts, the name of the corporation, and the business address of its corporate officials must be shown.

V. Bid Questions, Modifications, Withdrawal, and Opening

A. Bidder Requests for Information and Addendums. Requests for information from a Bidder shall be submitted **in writing only** to SWACO Procurement via e-mail at procurement@swaco.org or to SWACO, Attn: SWACO Procurement, 4239 London Groveport Road, Grove City, Ohio 43123. **Any and all such requests must be received no later than 4:00 p.m. on August 25, 2025.** SWACO shall respond to any properly submitted request for information by a written addendum issued to all Bidders who have obtained the Bid Documents for this Project.

1. In addition, SWACO, on its own initiative, may issue such other addenda as it may deem appropriate from time to time. No request for information shall be considered answered by SWACO until SWACO has issued an addendum in response to such request for information, and copies of the written request for information and SWACO's response has been issued to each Bidder.

2. Upon receipt of any addendum, Bidders shall notify SWACO in writing of its receipt of the addendum by completing the *Addendum Acknowledgement* form in **Exhibit B** and submit with their Bid submission.

B. Modification of Bids. At any time prior to the opening of Bids, a Bidder may modify its Bid in writing by submitting a modification marked in the same manner as the original document to SWACO. The document must be marked as a modification or replacement to the original electronic submission. Any such modification must be received by SWACO prior to the opening date and time of the Bids to be considered effective.

C. Withdrawal of Bid. Prior to the opening of Bids, a Bidder may withdraw its Bid provided the Bidder makes a written request to withdraw the Bid. Such requests must be received by procurement@swaco.org or at the address indicated above in Paragraph A prior to the Bid opening. The written request to withdraw must be executed by a party authorized to execute the Bid, include an executed Affidavit of Authority, and be electronically uploaded to the link provided in Section IV. Any properly withdrawn Bid shall be returned to the Bidder unopened.

D. Rejection or Waiver of Bids. SWACO may, in its sole and complete discretion, at any time prior to SWACO's Executive Director's execution of any contract that may be awarded to the apparent Successful Bidder, terminate the process set forth in this RFB and not accept any Bids; reject or waive any and/or all Bids; waive any irregularities contained in any Bid; and/or reject all bids and advertise for new Bids.

E. Bid Opening. All Bids received at or before 1:30 p.m., August 29, 2025, shall be electronically opened. Bid Results will be emailed to those who registered to download the Bid Documents.

F. Termination of RFB Process. SWACO reserves the right to terminate the process contained in this RFB and/or to reject any and/or all of the Bids on any basis without disclosure of a reason. Solicitation and/or opening of any Bid submitted in response to this RFB and the other Bid Documents does not create any express or implied obligation on SWACO to award the Proposed Contract. SWACO may, at its sole and complete discretion, disqualify and/or refuse to consider any Bid and/or Bids, and/or refuse to award the Proposed Contract to any Bidder and/or Bidders, for any reason, including, without limitation, the following:

1. The failure of a Bidder to respond to all requirements specified in the Bid Documents.
2. More than one (1) Bid for the Project is submitted from an individual, firm, joint venture, or corporation under the same or different name, or corporation under the same name or corporations with one (1) or more of the same persons as officers or directors of such corporations, or corporations which are holding companies, parent companies or sister companies which are subsidiaries of such corporations.
3. Evidence of collusion among Bidders.
4. Bid prices which are obviously unbalanced.

5. Bidder lacks sufficient experience, competency and/or adequate machinery, equipment, plant, or other resources to perform the Proposed Contract and/or as required by the other Bid Documents.
6. Evidence of uncompleted work, whether or not with SWACO, which, in the opinion of SWACO, might hinder or prevent the prompt delivery of the Project if it should be awarded to the Bidder.
7. Bidder has an “unresolved audit finding” issued by the Office of the Auditor of the State of Ohio.
8. For the reasons set forth below, Bids will be considered irregular and may, at SWACO’s sole and complete discretion, be rejected. However, SWACO is not obligated to reject such Bids.
 - a) If the Bid is on a form other than that furnished by SWACO and/or if the form is altered or any part thereof is detached. Computer generated facsimiles of SWACO’s forms are acceptable.
 - b) If there are unauthorized additions, conditions or alternate bids or irregularities of any kind which may tend to make the Bid incomplete, indefinite, or ambiguous as to its meaning.
 - c) If the Bidder adds any provisions reserving the right to accept or reject an award, and/or to enter into the Proposed Contract pursuant to an award. This does not exclude a Bid limiting the maximum gross amount of awards acceptable to any one (1) Bidder at any one (1) Bid letting, provided that any selection of awards will be made by SWACO.
 - d) If the Bid does not contain a price for a particular Bid item.
 - e) The Bidder fails to return all of the Bid forms included in the Bid Documents (including, without limitation, required affidavits), and/or to completely fill out the Bid forms and/or to provide complete responses for requested information.
 - f) If the Bid is not properly signed.

VI. Standard Terms and Conditions

- A. Budgeting. All budgets are subject to the annual appropriation of funds by the SWACO Board of Trustees. Budget information is not available for this Project; however, it is fully funded.
- B. Taxes and Payment. The Bidder is hereby notified that:
 1. SWACO is a Political subdivision pursuant to ORC Section 343 and exempt from State sales or use taxes. Therefore, such taxes shall not be included in any rate or price quotations submitted as part of any Bid; and
 2. SWACO does not pay retainers, deposits, or make any other advance payments prior to services rendered.
- C. Contract Termination. SWACO’s standard contract termination is at least fifteen (15) days in writing prior to the date of the intended early termination of the Proposed Contract.
- D. Pricing. Bidders are to quote firm or fixed prices for the duration of any contract which may be a result of the Bid unless otherwise noted in the Bid Documents. In case of discrepancy

in computing the amount of the Bid, the unit price quoted will govern. In the event of a conflict between the price in numbers and the price in words, the price in words will control.

E. Invoicing. All invoices shall be submitted monthly. Each invoice shall show the SWACO purchase order number, the quantity and brief description of the service performed, material or equipment furnished, and the total amount of cost.

1. Each invoice must separate and list this information per facility location.

2. If changes occur, other than the scheduled service, material or equipment ordered, invoice must state extra charges, hours, material or equipment, or services provided and include a brief description of extra charges, which must be preapproved in writing by SWACO. The invoice must indicate the SWACO personnel who authorized the changes and/or extra charges. If applicable, a copy of an executed “change order” must be included.

F. Additional Fees. Notwithstanding any term, condition, or provision set forth in the Bid, SWACO shall not be obligated or liable to the Successful Bidder and/or any other party for any late payment, collection costs, fees, and/or interest charges.

G. Indemnification and Insurance. Each Successful Bidder is advised that in addition to any other terms, conditions or provisions that may be contained in any contract awarded and executed as a result of this RFB (including without limitation warranty provisions), the Successful Bidder shall agree to the following indemnification and insurance provisions:

1. *General Duty to Indemnify SWACO.* The Successful Bidder shall indemnify and hold harmless SWACO, its trustees, officers, employees and representatives from and against all claims, damages, losses, liens, causes of action, suits, judgments, and expenses (including reasonable attorney's fees and other reasonable costs of defense), of any nature, kind or description, which (a) are caused by or result from the performance of the Services by the Successful Bidder, anyone directly or indirectly employed by the Successful Bidder, any sub-contractor of the Successful Bidder, or anyone for whose acts the Successful Bidder is legally liable, and (b) are attributable to bodily injury, personal injury, sickness, disease or death of any person, or to damage to or destruction of property, but (c) only to the extent they are caused by any negligent, reckless or willful act, error or omission of the Successful Bidder, anyone directly or indirectly employed by the Successful Bidder, any sub-contractor of the Successful Bidder, or anyone for whose acts the Successful Bidder is legally liable. The terms and conditions of this paragraph shall survive termination of this contract for any reason.

2. Successful Bidder shall promptly correct, repair, and/or replace any part, work, supplies and/or other materials installed as part of the Services and damaged and/or destroyed as a result of an insured loss or damage. Such correction, repair and/or replacement shall be the Successful Bidder’s sole responsibility and shall be undertaken and completed at no additional cost to SWACO.

3. **PLEASE NOTE: THE GENERAL DUTY TO INDEMNIFY SWACO IS NOT NEGOTIABLE. IF YOU ARE UNABLE TO AGREE TO THE PROVISION SET FORTH ABOVE, SWACO WILL BE UNABLE TO ENTER INTO A CONTRACT WITH YOUR COMPANY.**

4. *Liability Insurance.* The Successful Bidder shall purchase and maintain the following liability and other insurance at the indicated limits, under the terms set forth below:

- a) General Liability Insurance, containing the following limits and terms:
 - 1) \$1,000,000.00 per occurrence
 - 2) \$2,000,000.00 aggregate
 - 3) \$1,000,000.00 Products/Completed Operations Aggregate
 - 4) Name SWACO as an additional insured
 - 5) Waiver of subrogation in favor of SWACO and all related entities or subsidiaries, employees, agents and/or representatives
 - 6) Automobile Liability Insurance, containing a limit of \$1,000,000.00 per occurrence
 - 7) Worker's Compensation and Employer's Liability Insurance, containing the following limits:
 - Statutory Limits for the State of Ohio \$500,000.00/\$500,000.00/\$500,000.00 Employer's Liability Limit
 - 8) Professional Liability Insurance covering errors, omissions, and/or negligence of the Advisor with a coverage limit of \$5,000,000.00.
 - 9) Umbrella Liability Insurance containing the limit of \$4,000,000.00 per occurrence and terms including the following "form coverage."

b) **The limits set forth above may be adjusted according to industry standards, risk, and further assurances.**

c) Each policy of insurance required to be purchased and maintained by the Successful Bidder shall be purchased from an insurance carrier rated by A.M. Best as A-, VII or better;

d) Each policy and respective certificate of insurance shall expressly provide that should the Successful Bidder's insurance lapse, be cancelled, non-renewed or materially altered, the Successful Bidder shall provide SWACO with no less than thirty (30) days prior written notice of such cancellation, non-renewal, expiration or material alteration of the coverage contained in such policy or evidenced by such certificate of insurance.

e) The Successful Bidder shall maintain all insurance in the required amounts, without interruption, from the date of the execution of the contract until the date of the termination of the contract or the date of payment of the final invoice issued by Successful Bidder, whichever is later. Failure of the Successful Bidder to comply with the terms and conditions of this paragraph shall constitute a material breach of the contract and shall be cause for termination of this Contract by SWACO.

f) Insurance policies required to be purchased and maintained by the Successful Bidder may include a reasonable loss deductible, as is customary for the Successful Bidder's industry, which shall be the sole responsibility of the Successful Bidder to pay in the event of any covered loss.

5. SWACO and the Successful Bidder waive all rights against each other for damages caused by fire or other perils to the extent of actual recovery of any insurance proceeds under any property insurance obtained pursuant to the

requirements set forth above or any other property insurance applicable to the performance of the Services, except such rights as they have to proceeds of such insurance held by SWACO as fiduciary. The Successful Bidder agrees to obtain waivers in favor of SWACO of such claims by all of its subcontractors.

6. Notwithstanding the paragraph above, and regardless of the amount of any insurance proceeds recovered by the parties under the insurance policies set forth above, the Successful Bidder shall be liable to SWACO for the full amount of any claims, damages, losses, liens, causes of action, suits, judgments and expenses (including reasonable attorney's fees and other reasonable costs of defense) of any nature, kind or description which are in excess of such insurance proceeds.

VII. Applicable Law

A. Venue. Without regard to its own “choice of law” provisions, the bidding process and any Contract awarded as a result of the process set forth in this RFB shall be governed by the laws of the State of Ohio to the exclusion of the laws of any other jurisdiction. The State of Ohio shall have jurisdiction over any action hereunder or related to the implementation of the bidding process contained herein and the performance of any Contract awarded hereunder as a result of this bidding process to the exclusion of any other forum. Any action or proceeding shall take place in a court of law located in Franklin County, Ohio.

B. Non-Discrimination. Bidders shall not discriminate against any employee or qualified applicant for employment who is both available and qualified for work because of age, race, color, religion, sex, disability, creed, military status, or national origin. Bidders shall not discriminate based upon age, race, color, religion, sex, disability, creed, military status, or national origin in any undertaking related to employment including, but not limited to, such actions as hiring, upgrading, demotion or transfer, recruitment or recruitment advertising, layoff or termination, rates of pay or other forms of compensation, and selection for training, including apprenticeship.

C. Public Records. All Bidders are advised that Bids received by SWACO in response to this RFB may constitute public records as defined by Ohio Revised Code Section 149.43 and any additional information submitted by Bidder pursuant to this RFB shall become the property of SWACO. However, if there is material in a Bid that a Bidder deems to be confidential, it should be clearly identified as such, marked confidential, and accompanied by a written explanation stating the basis of such claim. Any confidential material that is properly designated shall be removed from the Bid prior to release of the Bid to the public if permitted by the laws of the State of Ohio including, without limitation, Ohio Revised Code Section 149.43. The determination as to the confidentiality of any material identified as confidential by a Bidder shall be made by SWACO in SWACO’s sole and complete discretion. SWACO shall assume no risk, nor shall it be held liable by any Bidder for the release of any material which Bidder may claim to be confidential. Submittal by Bidder of a Bid to SWACO shall be deemed acknowledgement of the terms and provisions contained in this paragraph C.

D. Prevailing Wages. Prevailing Wage rates of wages for workers employed on this Project are determined pursuant to the Ohio Department of Commerce. Prevailing Wage rates are included with the Bid Documents, attached hereto as **Exhibit G**; however, it is the responsibility of the Bidder to understand, and report correct prevailing wages (**Sections 4115.03 to 4115.16 of the Ohio Revised Code**).

VIII. Bid Award

A. Award Basis. There are estimated quantities listed in this RFB, and unit prices (to the nearest cent) are requested. Bids are on a firm basis and shall remain in effect for the term of the contract. Prices in the Bid shall govern for award evaluation and payment purposed. SWACO reserves the right to award this contract in the best interest of SWACO.

B. Lowest and Best. SWACO shall award the contract for the Project to the Bidder that submits the lowest and best responsive Bid. Bids will be evaluated within sixty (60) days of the Bid opening day. All Bidders shall allow SWACO sixty (60) days after the opening of Bids to make an award of Contract without invalidating their Bid(s). SWACO may, at its sole option, request any or all Bidders to provide additional information. Factors that determine the lowest and best responsive bid include without limitation:

1. The Bidder's responsiveness to the terms, conditions, provisions and/or specifications set forth in the Bid Documents.
2. The known quality of the Bidder's work on similar Projects.
3. The Bidder's capability to undertake the work of the Project in accordance with the terms, conditions, provisions and/or specifications contained in the Bid Documents, and including, without limitation, those contained in the Proposed Contract.
4. The Bidder's references.
5. Bidder warranties.

C. Notice of Award. SWACO shall issue a letter indicating SWACO's intent to award the Contract to the Bidder submitting the lowest and best responsive bid ("Successful Bidder"), if any. An award is effective only upon execution of a written Contract by both SWACO's Executive Director, pursuant to its Procurement Policy, and the Successful Bidder (if any).

IX. Awarding the Contract

A. Information Provided to Successful Bidder. SWACO shall provide to the Successful Bidder, upon request, any information concerning the Project to which it has access. SWACO may, at its sole option, provide information to the Successful Bidder in electronic format.

B. Contract Execution. Any Contract awarded as a result of the bidding process set forth in this RFB and the other Bid Documents shall be executed by the Successful Bidder and returned to SWACO pursuant to the terms, conditions, and provisions set forth in the Bid Documents and pertinent provisions of the Ohio Revised Code, within thirty (30) days after the Bidder has received notice of the award of the Contract and the Contract for signature. No Bid or Contract shall be considered binding upon SWACO until execution of the Contract by SWACO's Executive Director and, if required by SWACO's procurement policy or deemed appropriate by SWACO staff, approval of the Contract by SWACO's Board of Trustees.

1. SWACO may, at SWACO's sole and complete discretion, withdraw the award of the Contract to the Successful Bidder if the Successful Bidder shall fail to execute the Contract and return the executed Contract to SWACO within thirty (30) days of receipt of the notice of award of the Contract.
2. If SWACO should withdraw the award of the Contract to a Successful Bidder pursuant to subparagraph 1 above, SWACO may, in its sole and complete discretion, award the Contract to the next lowest and best responsive Bidder, re-advertise and re-bid the entire Project, or not award the Contract at all.

Exhibit A

003. Project Information

I. Project Information

- A. The Project scope generally encompasses installing a new 480Y/277V, 400A, three- (3)-phase power service from existing AEP overhead three- (3)-phase service. This new service shall accommodate the installation of a seventy-five (75) horsepower dewatering pump and VFD, six (6) power receptable pedestals, two (2) overhead utility lights, and a security camera. Service conductors will run underground from the AEP service pole to a new service equipment rack.
- B. The purchase and installation of a security camera system is specified as an Axis P3735-PLE Panoramic Camera, Point to Point Wireless Bridge, and Network Switch.
- C. The purchase and installation of the dewatering pump and VFD setup and is specified to include Xylem CD150S 75 HP with VFD, or equivalent, one hundred (100) feet of twelve-inch (12”) DR17 HDPE suction pipe with floating tee, four hundred (400) feet of eight-inch (8”) discharge hose, and any other appurtenances. All equipment as part of this Bid Item is to be submitted with the Bid and is to be approved by SWACO prior to contract award.
- D. Successful Bidder must be a state-licensed electrician and is responsible for complying with all permit requirements. Electrical permits and inspections for commercial properties in Pleasant Township will be obtained through the Ohio Department of Commerce: Bureau of Building Code Compliance.
- E. The engineer for the Project is Affinity Infrastructure, LLC, 200 East Campus View Blvd., Suite 200, Columbus, OH 43235.
- F. Milestones
 - Anticipated Contract Award September 9, 2025
 - Completion of WorkOctober 31, 2025
 - Work Complete and Ready for Final PaymentNovember 7, 2025
- G. A virtual pre-bid meeting is scheduled on Tuesday, August 19, 2025, at 1:00 p.m. (EST):

Microsoft Teams

[Join the meeting now](#)

Meeting ID: 244 315 097 412 2

Passcode: tD75HF6u

Dial in by phone

[+1 513-301-2202,,393166339#](#) United States, Cincinnati

[Find a local number](#)

Phone conference ID: 393 166 339#

For organizers: [Meeting options](#) | [Reset dial-in PIN](#)

H. Work Hours

1. Work hours for this Project are permissible during daylight hours only and are designated below:
Monday through Friday7:00 a.m. to 5:00 p.m.
Saturday7: 00 a.m. to 12:00 p.m.
Sunday.....No Work
2. Any additional hours outside of the designated work hours above (for placing concrete, etc.) MUST be pre-approved by SWACO’s project manager.
3. No work shall be performed without a SWACO designated representative onsite.

II. General Information

- A. There will be no exceptions to extend time for bidding or construction.
- B. Bid Tab included with the RFB. Bid pricing is to include all work shown in the Bid documents. It is the Bidder's responsibility to assign costs to the appropriate bid item. Any questions as to the scope of work are to be addressed prior to submitting the bid.
For example, when pricing out Bid Item 7 – Dewatering Pump, Bidder is to include all conduit, wiring, junction box, disconnect rack, pump materials, and labor. The intent is to capture pricing for all work in the plans and Bid documents in the Bid Tab. If Bidder is unclear as to which Bid item the work should be charged to, Bidder can request clarification from SWACO.
- C. Any questions to the scope of work are to be addressed prior to submitting the Bid by submitting questions in writing to procurement@swaco.org.
- D. Bi-weekly meetings are to be attended by the Contractor’s project manager and superintendent.
- E. Contractors are never permitted to work without a SWACO designated representative onsite.

III. Measurement and Payment Section

Bid Item 1 – Mobilization/Demobilization

Includes all labor, equipment, and material to the site, as well as contractor provided utilities and ongoing related expenses required for administration of the work. Surface preparation required by the Contractor for staging areas and parking areas will be paid of this item. Additionally, mobilization shall include bonds and insurance. Mobilization will be paid at the rate of fifty percent (50%) of the first payment application.

Bid Item 2 – Electrical Equipment Rack

Includes all labor, materials, and equipment to install the equipment rack shown on drawings E-2, E-3, and E-4. Also include costs for conduit and wiring from AEP transformer to rack.

Bid Item 3 – Utility Lighting

Includes all labor, materials, and equipment to install utility lighting pole foundations, poles, lights, conduit, wiring, and other appurtenance listed in drawing E-2 and E-3.

Bid Item 4 – Security Camera/Wi-Fi Bridge/ Network Switch

Includes all labor, materials, and equipment to install camera on utility lighting pole shown on drawing E-2. Also include costs for conduit and wiring from equipment rack to the camera.

Bid Item 5 – Block Heater Receptacle Power Pedestals

Includes all labor, materials, and equipment to install pedestals shown on drawing E-2. Also include costs for conduit and wiring from equipment rack to each pedestal.

Bid Item 6 – Heavy Duty Protection Bollard

Includes all labor, materials, and equipment to install the heavy-duty protection bollards shown on drawings E-2 and E-3.

Bid Item 7 – Dewatering Pump & VFD Setup

Includes all labor, materials, and equipment to install dewatering pump on drawings E-1 and E-2. Also include costs for disconnect rack, junction box, and conduit and wiring from equipment rack to the pump and VFD. Pump and VFD setup is to include Xylem CD150S 75 HP with VFD, or equivalent, one hundred (100) feet of twelve-inch (12”) DR17 HDPE suction pipe with floating tee, four hundred (400) feet of eight-inch (8”) discharge hose, and any other appurtenances. All equipment as part of this Bid Item is to be submitted with the Bid and is to be approved by SWACO prior to contract award.

Exhibit B

004. Required Forms and Documents

I. Required Forms

- a) Bid with Bid Sheet and Bidder's Representative
- b) Non-Collusion Affidavit
- c) Non-Discrimination Affidavit
- d) Affidavit of Authority
- e) Delinquent Tax Affidavit
- f) W-9 Form (*Rev. March 2024 by the IRS*)
- g) Addendum Acknowledgement
- h) RFB Exceptions
- i) Acknowledgement (Local, Certified, EOE, and Green)

II. Required Documents from Bidder

- a) Bidder's Statement
- b) Bid Guaranty for Bid Bond
- c) Consent of Surety for Payment Bond

BID SHEET

To the Solid Waste Authority of Central Ohio (“SWACO”), Franklin County, Ohio, to provide the Project as outlined in this RFB and in accordance with the specifications provided; therefore, **EACH BIDDER MUST TAKE NOTICE OF THE FACT THAT EVEN THOUGH ITS BID MAY BE ACCEPTED AND THE DOCUMENTS SIGNED BY THE BIDDER TO WHOM AN AWARD IS MADE AND BY SWACO, THAT NO SUCH AWARD OR SIGNING BY SWACO SHALL BE CONSIDERED A BINDING CONTRACT WITHOUT THE PROPER CERTIFICATE BY THE FISCAL OFFICER OF SWACO INDICATING THAT FUNDS ARE AVAILABLE TO COVER THE COST OF THE WORK TO BE DONE, OR WITHOUT THE APPROVAL OF THE LEGAL COUNSEL OF SWACO AS TO THE FORM OF THE CONTRACT AND ALL THE PERTINENT DOCUMENTS RELATING THERETO HAVING BEEN APPROVED BY SAID LEGAL COUNSEL OF SWACO AND SUCH BIDDER IS HEREBY CHARGED WITH THIS NOTICE.**

The signer of the Bid, as Bidder, also declares that the only person, persons, company or parties interested in this Bid are named in this Bid, that he/she has carefully examined the advertisement, instructions to Bidders, General Conditions, sample contract documents, and all other documents related to this Bid as listed in the “Table of Contents” section of the Request for Bid package; that the Bidder or his/her representative has made such investigation as is necessary to determine the character and extent of the purchase and he/she proposes and agrees that if this Bid be accepted he/she will contract with SWACO to perform all necessary procedures in order to execute SWACO’s purchase within the time period set forth and according to the requirements of SWACO herein and hereinafter set forth for the following prices:

THE BIDDER’S LUMP SUM TOTALS BELOW ARE ITS TOTAL BIDS BASED ON UNIT PRICES. THESE FIGURES ARE FOR INFORMATION ONLY AT THE TIME OF OPENING BIDS. SWACO WILL MAKE THE TABULATION FROM THE UNIT PRICES. IF THERE IS AN ERROR IN THE LUMP SUM TOTAL BY THE BIDDER, IT SHALL BE CHANGED AS ONLY THE LUMP SUM PRICES SHALL GOVERN.

BID SHEET (CONTINUED)

This Bid is to provide the Project according to the information provided in the Request for Bid documents.

Company Name _____

Bid Tab

BID ITEM	DESCRIPTION	ESTIMATED QUANTITY	UNIT	UNIT PRICE	TOTAL
1	Mobilization / Demobilization	1	LS	\$	\$
2	Dewatering Pump	1	LS	\$	\$
3	Security Camera/Wifi Bridge/Network Switch	1	LS	\$	\$
4	Light Poles	2	EA	\$	\$
5	Bollards	8	EA	\$	\$
6	Receptacle Power Pedestals	6	EA	\$	\$
7	Transformer Pad	1	EA	\$	\$
8	Electrical Equipment Rack	1	LS	\$	\$
TOTAL					\$

Note: All work in Bid must reflect all notes, specifications, and details outlined in the construction drawings and associated documents.

Proposed construction schedule: _____

[Write out the Total Bid Amount below]

Submitted this _____ day of _____, 20_____.

By: _____
Authorized Signature

Bidder's Representative

Contact Person for this Bid _____

Title _____

E-mail Address _____

Company Name _____

Mailing Address _____

City, State, Zip _____

Phone Number _____ Fax Number _____

Mobile Number _____

Attach additional paperwork if necessary.

If Bidder is:

An Individual

By: _____
(Individual's signature)

(Printed or typed name of individual)

Doing business as: _____

License or Registration Number: _____

Business Address: _____

Phone No. _____ Fax No.: _____

~~~~~

**A Partnership**

By: \_\_\_\_\_  
(Firm name)

\_\_\_\_\_  
(General partner's signature)

\_\_\_\_\_  
(Printed or typed name of general partner) (Attach evidence of authority to sign.)

License or Registration Number: \_\_\_\_\_

Business Address: \_\_\_\_\_

Phone No. \_\_\_\_\_ Fax No.: \_\_\_\_\_

~~~~~

A Corporation

By: _____
(Corporation name)

(State of incorporation)

By: _____
(Signature of officer authorized to sign)

(Printed or typed name and title of officer authorized to sign. Attach evidence of authority to sign.)

(CORPORATE SEAL)

Attest: _____
(Secretary)

License or Registration Number: _____

Business Address: _____

Phone No. _____ Fax No.: _____

~~~~~

**Limited Liability Company**

By: \_\_\_\_\_  
(Firm name)

\_\_\_\_\_  
(State of formation)

By: \_\_\_\_\_  
(Signature of member authorized to sign)

\_\_\_\_\_  
(Printed /typed name and title of authorized member. Attach evidence of authority to sign.)

License or Registration Number: \_\_\_\_\_

Business Address: \_\_\_\_\_

Phone No. \_\_\_\_\_ Fax No.: \_\_\_\_\_

~~~~~

A Joint Venture

Joint Venture Name: _____

By: _____
(Signature)

(Printed or Typed Name) (Title)

By: _____
(Signature)

(Printed or Typed Name) (Title)

(Address)

Phone and fax number and address for receipt of communications to joint venture:

(Each joint venturer must sign. The manner of signing for each individual, partnership, corporation or limited liability company that is a party to the joint venture shall be in the manner indicated above).

++ END OF BID FORM ++

NON-DISCRIMINATION AFFIDAVIT

STATE OF _____)
) ss
COUNTY OF _____)

_____ being duly sworn, deposes and states that during the term
Affiant
and performance of any agreement or contract between the Solid Waste Authority of Central Ohio
and _____ (“Bidder”) that neither Bidder nor any
subcontractor of Bidder shall discriminate against any employee or qualified applicant for
employment who is both available and qualified for work because of age, race, color, religion, sex,
disability, creed, military status, or national origin. Further, Bidder agrees that neither it nor any
subcontractor shall discriminate based upon age, race, color, religion, sex, disability, creed,
military status, or national origin in any undertaking related to employment including, but not
limited to, such actions as hiring, upgrading, demotion or transfer, recruitment or recruitment
advertising, layoff or termination, rates of pay or other forms of compensation, and selection for
training, including apprenticeship.

Affiant's Signature

Affiant's Printed Name

Sworn to before me and subscribed in my presence this ____ day of _____, 20__.

Notary Public

My Commission Expires: _____
(Date)

(County) *(State)*

NON-COLLUSION AFFIDAVIT

(This affidavit must be executed for the Bidder to be considered)

STATE OF _____)
) SS
COUNTY OF _____)

_____, being duly sworn, deposes and says that he/she is
(Name)

_____ of _____
(Title) (Company Name)

the party making the foregoing Bid; that such Bid is genuine and not collusive or sham; that said Bidder is not financially interested in, or otherwise affiliated in a business way with any other Bidder on the same contract; that said Bidder has not colluded, conspired, connived, or agreed, directly or indirectly with any Bidder or person, to put in a sham Bid, or that such other person shall refrain from submitting a Bid, and has not in any manner, directly or indirectly sought by agreement or collusion, or communication or conference, with any person to fix the Bid price of Affiant or any other Bidder, or to fix any overhead profit of cost element of said Bid price, or of that of any other Bidder, or to secure any advantage against Solid Waste Authority of Central Ohio, State of Ohio, or any person or persons interested in the proposed contract; and that all statements contained in this Bid are true; and further, that such Bidder has not, directly or indirectly, submitted this Bid or the contents thereof; or divulged information or data relative to any association or to any member or agent thereof.

Affiant

Sworn to before me and subscribed in my presence this _____ day of _____, 20_____.

Notary Public

My Commission Expires:

must obtain your correct taxpayer identification number (TIN), which may be your social security number (SSN), individual taxpayer identification number (ITIN), adoption taxpayer identification number (ATIN), or employer identification number (EIN), to report on an information return the amount paid to you, or other amount reportable on an information return. Examples of information returns include, but are not limited to, the following.

- Form 1099-INT (interest earned or paid).
- Form 1099-DIV (dividends, including those from stocks or mutual funds).
- Form 1099-MISC (various types of income, prizes, awards, or gross proceeds).
- Form 1099-NEC (nonemployee compensation).
- Form 1099-B (stock or mutual fund sales and certain other transactions by brokers).
- Form 1099-S (proceeds from real estate transactions).
- Form 1099-K (merchant card and third-party network transactions).
- Form 1098 (home mortgage interest), 1098-E (student loan interest), and 1098-T (tuition).
- Form 1099-C (canceled debt).
- Form 1099-A (acquisition or abandonment of secured property).

Use Form W-9 only if you are a U.S. person (including a resident alien), to provide your correct TIN.

Caution: If you don't return Form W-9 to the requester with a TIN, you might be subject to backup withholding. See *What is backup withholding*, later.

By signing the filled-out form, you:

1. Certify that the TIN you are giving is correct (or you are waiting for a number to be issued);
2. Certify that you are not subject to backup withholding; or
3. Claim exemption from backup withholding if you are a U.S. exempt payee; and
4. Certify to your non-foreign status for purposes of withholding under chapter 3 or 4 of the Code (if applicable); and
5. Certify that FATCA code(s) entered on this form (if any) indicating that you are exempt from the FATCA reporting is correct. See *What Is FATCA Reporting*, later, for further information.

Note: If you are a U.S. person and a requester gives you a form other than Form W-9 to request your TIN, you must use the requester's form if it is substantially similar to this Form W-9.

Definition of a U.S. person. For federal tax purposes, you are considered a U.S. person if you are:

- An individual who is a U.S. citizen or U.S. resident alien;
- A partnership, corporation, company, or association created or organized in the United States or under the laws of the United States;
- An estate (other than a foreign estate); or
- A domestic trust (as defined in Regulations section 301.7701-7).

Establishing U.S. status for purposes of chapter 3 and chapter 4 withholding. Payments made to foreign persons, including certain distributions, allocations of income, or transfers of sales proceeds, may be subject to withholding under chapter 3 or chapter 4 of the Code (sections 1441–1474). Under those rules, if a Form W-9 or other certification of non-foreign status has not been received, a withholding agent, transferee, or partnership (payor) generally applies presumption rules that may require the payor to withhold applicable tax from the recipient, owner, transferor, or partner (payee). See Pub. 515, *Withholding of Tax on Nonresident Aliens and Foreign Entities*.

The following persons must provide Form W-9 to the payor for purposes of establishing its non-foreign status.

- In the case of a disregarded entity with a U.S. owner, the U.S. owner of the disregarded entity and not the disregarded entity.
- In the case of a grantor trust with a U.S. grantor or other U.S. owner, generally, the U.S. grantor or other U.S. owner of the grantor trust and not the grantor trust.
- In the case of a U.S. trust (other than a grantor trust), the U.S. trust and not the beneficiaries of the trust.

See Pub. 515 for more information on providing a Form W-9 or a certification of non-foreign status to avoid withholding.

Foreign person. If you are a foreign person or the U.S. branch of a foreign bank that has elected to be treated as a U.S. person (under Regulations section 1.1441-1(b)(2)(iv) or other applicable section for chapter 3 or 4 purposes), do not use Form W-9. Instead, use the appropriate Form W-8 or Form 8233 (see Pub. 515). If you are a qualified foreign pension fund under Regulations section 1.897(l)-1(d), or a partnership that is wholly owned by qualified foreign pension funds, that is treated as a non-foreign person for purposes of section 1445 withholding, do not use Form W-9. Instead, use Form W-8EXP (or other certification of non-foreign status).

Nonresident alien who becomes a resident alien. Generally, only a nonresident alien individual may use the terms of a tax treaty to reduce or eliminate U.S. tax on certain types of income. However, most tax treaties contain a provision known as a saving clause. Exceptions specified in the saving clause may permit an exemption from tax to continue for certain types of income even after the payee has otherwise become a U.S. resident alien for tax purposes.

If you are a U.S. resident alien who is relying on an exception contained in the saving clause of a tax treaty to claim an exemption from U.S. tax on certain types of income, you must attach a statement to Form W-9 that specifies the following five items.

1. The treaty country. Generally, this must be the same treaty under which you claimed exemption from tax as a nonresident alien.
2. The treaty article addressing the income.
3. The article number (or location) in the tax treaty that contains the saving clause and its exceptions.
4. The type and amount of income that qualifies for the exemption from tax.
5. Sufficient facts to justify the exemption from tax under the terms of the treaty article.

Example. Article 20 of the U.S.-China income tax treaty allows an exemption from tax for scholarship income received by a Chinese student temporarily present in the United States. Under U.S. law, this student will become a resident alien for tax purposes if their stay in the United States exceeds 5 calendar years. However, paragraph 2 of the first Protocol to the U.S.-China treaty (dated April 30, 1984) allows the provisions of Article 20 to continue to apply even after the Chinese student becomes a resident alien of the United States. A Chinese student who qualifies for this exception (under paragraph 2 of the first Protocol) and is relying on this exception to claim an exemption from tax on their scholarship or fellowship income would attach to Form W-9 a statement that includes the information described above to support that exemption.

If you are a nonresident alien or a foreign entity, give the requester the appropriate completed Form W-8 or Form 8233.

Backup Withholding

What is backup withholding? Persons making certain payments to you must under certain conditions withhold and pay to the IRS 24% of such payments. This is called "backup withholding." Payments that may be subject to backup withholding include, but are not limited to, interest, tax-exempt interest, dividends, broker and barter exchange transactions, rents, royalties, nonemployee pay, payments made in settlement of payment card and third-party network transactions, and certain payments from fishing boat operators. Real estate transactions are not subject to backup withholding.

You will not be subject to backup withholding on payments you receive if you give the requester your correct TIN, make the proper certifications, and report all your taxable interest and dividends on your tax return.

Payments you receive will be subject to backup withholding if:

1. You do not furnish your TIN to the requester;
2. You do not certify your TIN when required (see the instructions for Part II for details);
3. The IRS tells the requester that you furnished an incorrect TIN;
4. The IRS tells you that you are subject to backup withholding because you did not report all your interest and dividends on your tax return (for reportable interest and dividends only); or
5. You do not certify to the requester that you are not subject to backup withholding, as described in item 4 under "*By signing the filled-out form*" above (for reportable interest and dividend accounts opened after 1983 only).

Certain payees and payments are exempt from backup withholding. See *Exempt payee code*, later, and the separate Instructions for the Requester of Form W-9 for more information.

See also *Establishing U.S. status for purposes of chapter 3 and chapter 4 withholding*, earlier.

What Is FATCA Reporting?

The Foreign Account Tax Compliance Act (FATCA) requires a participating foreign financial institution to report all U.S. account holders that are specified U.S. persons. Certain payees are exempt from FATCA reporting. See *Exemption from FATCA reporting code*, later, and the Instructions for the Requester of Form W-9 for more information.

Updating Your Information

You must provide updated information to any person to whom you claimed to be an exempt payee if you are no longer an exempt payee and anticipate receiving reportable payments in the future from this person. For example, you may need to provide updated information if you are a C corporation that elects to be an S corporation, or if you are no longer tax exempt. In addition, you must furnish a new Form W-9 if the name or TIN changes for the account, for example, if the grantor of a grantor trust dies.

Penalties

Failure to furnish TIN. If you fail to furnish your correct TIN to a requester, you are subject to a penalty of \$50 for each such failure unless your failure is due to reasonable cause and not to willful neglect.

Civil penalty for false information with respect to withholding. If you make a false statement with no reasonable basis that results in no backup withholding, you are subject to a \$500 penalty.

Criminal penalty for falsifying information. Willfully falsifying certifications or affirmations may subject you to criminal penalties including fines and/or imprisonment.

Misuse of TINs. If the requester discloses or uses TINs in violation of federal law, the requester may be subject to civil and criminal penalties.

Specific Instructions

Line 1

You must enter one of the following on this line; **do not** leave this line blank. The name should match the name on your tax return.

If this Form W-9 is for a joint account (other than an account maintained by a foreign financial institution (FFI)), list first, and then circle, the name of the person or entity whose number you entered in Part I of Form W-9. If you are providing Form W-9 to an FFI to document a joint account, each holder of the account that is a U.S. person must provide a Form W-9.

• **Individual.** Generally, enter the name shown on your tax return. If you have changed your last name without informing the Social Security Administration (SSA) of the name change, enter your first name, the last name as shown on your social security card, and your new last name.

Note for ITIN applicant: Enter your individual name as it was entered on your Form W-7 application, line 1a. This should also be the same as the name you entered on the Form 1040 you filed with your application.

• **Sole proprietor.** Enter your individual name as shown on your Form 1040 on line 1. Enter your business, trade, or "doing business as" (DBA) name on line 2.

• **Partnership, C corporation, S corporation, or LLC, other than a disregarded entity.** Enter the entity's name as shown on the entity's tax return on line 1 and any business, trade, or DBA name on line 2.

• **Other entities.** Enter your name as shown on required U.S. federal tax documents on line 1. This name should match the name shown on the charter or other legal document creating the entity. Enter any business, trade, or DBA name on line 2.

• **Disregarded entity.** In general, a business entity that has a single owner, including an LLC, and is not a corporation, is disregarded as an entity separate from its owner (a disregarded entity). See Regulations section 301.7701-2(c)(2). A disregarded entity should check the appropriate box for the tax classification of its owner. Enter the owner's name on line 1. The name of the owner entered on line 1 should never be a disregarded entity. The name on line 1 should be the name shown on the income tax return on which the income should be reported. For

example, if a foreign LLC that is treated as a disregarded entity for U.S. federal tax purposes has a single owner that is a U.S. person, the U.S. owner's name is required to be provided on line 1. If the direct owner of the entity is also a disregarded entity, enter the first owner that is not disregarded for federal tax purposes. Enter the disregarded entity's name on line 2. If the owner of the disregarded entity is a foreign person, the owner must complete an appropriate Form W-8 instead of a Form W-9. This is the case even if the foreign person has a U.S. TIN.

Line 2

If you have a business name, trade name, DBA name, or disregarded entity name, enter it on line 2.

Line 3a

Check the appropriate box on line 3a for the U.S. federal tax classification of the person whose name is entered on line 1. Check only one box on line 3a.

IF the entity/individual on line 1 is a(n) . . .	THEN check the box for . . .
• Corporation	Corporation.
• Individual or • Sole proprietorship	Individual/sole proprietor.
• LLC classified as a partnership for U.S. federal tax purposes or • LLC that has filed Form 8832 or 2553 electing to be taxed as a corporation	Limited liability company and enter the appropriate tax classification: P = Partnership, C = C corporation, or S = S corporation.
• Partnership	Partnership.
• Trust/estate	Trust/estate.

Line 3b

Check this box if you are a partnership (including an LLC classified as a partnership for U.S. federal tax purposes), trust, or estate that has any foreign partners, owners, or beneficiaries, and you are providing this form to a partnership, trust, or estate, in which you have an ownership interest. You must check the box on line 3b if you receive a Form W-8 (or documentary evidence) from any partner, owner, or beneficiary establishing foreign status or if you receive a Form W-9 from any partner, owner, or beneficiary that has checked the box on line 3b.

Note: A partnership that provides a Form W-9 and checks box 3b may be required to complete Schedules K-2 and K-3 (Form 1065). For more information, see the Partnership Instructions for Schedules K-2 and K-3 (Form 1065).

If you are required to complete line 3b but fail to do so, you may not receive the information necessary to file a correct information return with the IRS or furnish a correct payee statement to your partners or beneficiaries. See, for example, sections 6698, 6722, and 6724 for penalties that may apply.

Line 4 Exemptions

If you are exempt from backup withholding and/or FATCA reporting, enter in the appropriate space on line 4 any code(s) that may apply to you.

Exempt payee code.

- Generally, individuals (including sole proprietors) are not exempt from backup withholding.
- Except as provided below, corporations are exempt from backup withholding for certain payments, including interest and dividends.
- Corporations are not exempt from backup withholding for payments made in settlement of payment card or third-party network transactions.
- Corporations are not exempt from backup withholding with respect to attorneys' fees or gross proceeds paid to attorneys, and corporations that provide medical or health care services are not exempt with respect to payments reportable on Form 1099-MISC.

The following codes identify payees that are exempt from backup withholding. Enter the appropriate code in the space on line 4.

1—An organization exempt from tax under section 501(a), any IRA, or a custodial account under section 403(b)(7) if the account satisfies the requirements of section 401(f)(2).

- 2—The United States or any of its agencies or instrumentalities.
- 3—A state, the District of Columbia, a U.S. commonwealth or territory, or any of their political subdivisions or instrumentalities.
- 4—A foreign government or any of its political subdivisions, agencies, or instrumentalities.
- 5—A corporation.
- 6—A dealer in securities or commodities required to register in the United States, the District of Columbia, or a U.S. commonwealth or territory.
- 7—A futures commission merchant registered with the Commodity Futures Trading Commission.
- 8—A real estate investment trust.
- 9—An entity registered at all times during the tax year under the Investment Company Act of 1940.
- 10—A common trust fund operated by a bank under section 584(a).
- 11—A financial institution as defined under section 581.
- 12—A middleman known in the investment community as a nominee or custodian.
- 13—A trust exempt from tax under section 664 or described in section 4947.

The following chart shows types of payments that may be exempt from backup withholding. The chart applies to the exempt payees listed above, 1 through 13.

IF the payment is for . . .	THEN the payment is exempt for . . .
• Interest and dividend payments	All exempt payees except for 7.
• Broker transactions	Exempt payees 1 through 4 and 6 through 11 and all C corporations. S corporations must not enter an exempt payee code because they are exempt only for sales of noncovered securities acquired prior to 2012.
• Barter exchange transactions and patronage dividends	Exempt payees 1 through 4.
• Payments over \$600 required to be reported and direct sales over \$5,000 ¹	Generally, exempt payees 1 through 5. ²
• Payments made in settlement of payment card or third-party network transactions	Exempt payees 1 through 4.

¹ See Form 1099-MISC, Miscellaneous Information, and its instructions.

² However, the following payments made to a corporation and reportable on Form 1099-MISC are not exempt from backup withholding: medical and health care payments, attorneys' fees, gross proceeds paid to an attorney reportable under section 6045(f), and payments for services paid by a federal executive agency.

Exemption from FATCA reporting code. The following codes identify payees that are exempt from reporting under FATCA. These codes apply to persons submitting this form for accounts maintained outside of the United States by certain foreign financial institutions. Therefore, if you are only submitting this form for an account you hold in the United States, you may leave this field blank. Consult with the person requesting this form if you are uncertain if the financial institution is subject to these requirements. A requester may indicate that a code is not required by providing you with a Form W-9 with "Not Applicable" (or any similar indication) entered on the line for a FATCA exemption code.

- A—An organization exempt from tax under section 501(a) or any individual retirement plan as defined in section 7701(a)(37).
- B—The United States or any of its agencies or instrumentalities.
- C—A state, the District of Columbia, a U.S. commonwealth or territory, or any of their political subdivisions or instrumentalities.
- D—A corporation the stock of which is regularly traded on one or more established securities markets, as described in Regulations section 1.1472-1(c)(1)(i).
- E—A corporation that is a member of the same expanded affiliated group as a corporation described in Regulations section 1.1472-1(c)(1)(i).

F—A dealer in securities, commodities, or derivative financial instruments (including notional principal contracts, futures, forwards, and options) that is registered as such under the laws of the United States or any state.

G—A real estate investment trust.

H—A regulated investment company as defined in section 851 or an entity registered at all times during the tax year under the Investment Company Act of 1940.

I—A common trust fund as defined in section 584(a).

J—A bank as defined in section 581.

K—A broker.

L—A trust exempt from tax under section 664 or described in section 4947(a)(1).

M—A tax-exempt trust under a section 403(b) plan or section 457(g) plan.

Note: You may wish to consult with the financial institution requesting this form to determine whether the FATCA code and/or exempt payee code should be completed.

Line 5

Enter your address (number, street, and apartment or suite number). This is where the requester of this Form W-9 will mail your information returns. If this address differs from the one the requester already has on file, enter "NEW" at the top. If a new address is provided, there is still a chance the old address will be used until the payor changes your address in their records.

Line 6

Enter your city, state, and ZIP code.

Part I. Taxpayer Identification Number (TIN)

Enter your TIN in the appropriate box. If you are a resident alien and you do not have, and are not eligible to get, an SSN, your TIN is your IRS ITIN. Enter it in the entry space for the Social security number. If you do not have an ITIN, see *How to get a TIN* below.

If you are a sole proprietor and you have an EIN, you may enter either your SSN or EIN.

If you are a single-member LLC that is disregarded as an entity separate from its owner, enter the owner's SSN (or EIN, if the owner has one). If the LLC is classified as a corporation or partnership, enter the entity's EIN.

Note: See *What Name and Number To Give the Requester*, later, for further clarification of name and TIN combinations.

How to get a TIN. If you do not have a TIN, apply for one immediately. To apply for an SSN, get Form SS-5, Application for a Social Security Card, from your local SSA office or get this form online at www.SSA.gov. You may also get this form by calling 800-772-1213. Use Form W-7, Application for IRS Individual Taxpayer Identification Number, to apply for an ITIN, or Form SS-4, Application for Employer Identification Number, to apply for an EIN. You can apply for an EIN online by accessing the IRS website at www.irs.gov/EIN. Go to www.irs.gov/Forms to view, download, or print Form W-7 and/or Form SS-4. Or, you can go to www.irs.gov/OrderForms to place an order and have Form W-7 and/or Form SS-4 mailed to you within 15 business days.

If you are asked to complete Form W-9 but do not have a TIN, apply for a TIN and enter "Applied For" in the space for the TIN, sign and date the form, and give it to the requester. For interest and dividend payments, and certain payments made with respect to readily tradable instruments, you will generally have 60 days to get a TIN and give it to the requester before you are subject to backup withholding on payments. The 60-day rule does not apply to other types of payments. You will be subject to backup withholding on all such payments until you provide your TIN to the requester.

Note: Entering "Applied For" means that you have already applied for a TIN or that you intend to apply for one soon. See also *Establishing U.S. status for purposes of chapter 3 and chapter 4 withholding*, earlier, for when you may instead be subject to withholding under chapter 3 or 4 of the Code.

Caution: A disregarded U.S. entity that has a foreign owner must use the appropriate Form W-8.

Part II. Certification

To establish to the withholding agent that you are a U.S. person, or resident alien, sign Form W-9. You may be requested to sign by the withholding agent even if item 1, 4, or 5 below indicates otherwise.

For a joint account, only the person whose TIN is shown in Part I should sign (when required). In the case of a disregarded entity, the person identified on line 1 must sign. Exempt payees, see *Exempt payee code*, earlier.

Signature requirements. Complete the certification as indicated in items 1 through 5 below.

1. Interest, dividend, and barter exchange accounts opened before 1984 and broker accounts considered active during 1983. You must give your correct TIN, but you do not have to sign the certification.

2. Interest, dividend, broker, and barter exchange accounts opened after 1983 and broker accounts considered inactive during 1983. You must sign the certification or backup withholding will apply. If you are subject to backup withholding and you are merely providing your correct TIN to the requester, you must cross out item 2 in the certification before signing the form.

3. Real estate transactions. You must sign the certification. You may cross out item 2 of the certification.

4. Other payments. You must give your correct TIN, but you do not have to sign the certification unless you have been notified that you have previously given an incorrect TIN. "Other payments" include payments made in the course of the requester's trade or business for rents, royalties, goods (other than bills for merchandise), medical and health care services (including payments to corporations), payments to a nonemployee for services, payments made in settlement of payment card and third-party network transactions, payments to certain fishing boat crew members and fishermen, and gross proceeds paid to attorneys (including payments to corporations).

5. Mortgage interest paid by you, acquisition or abandonment of secured property, cancellation of debt, qualified tuition program payments (under section 529), ABL accounts (under section 529A), IRA, Coverdell ESA, Archer MSA or HSA contributions or distributions, and pension distributions. You must give your correct TIN, but you do not have to sign the certification.

What Name and Number To Give the Requester

For this type of account:	Give name and SSN of:
1. Individual	The individual
2. Two or more individuals (joint account) other than an account maintained by an FFI	The actual owner of the account or, if combined funds, the first individual on the account ¹
3. Two or more U.S. persons (joint account maintained by an FFI)	Each holder of the account
4. Custodial account of a minor (Uniform Gift to Minors Act)	The minor ²
5. a. The usual revocable savings trust (grantor is also trustee)	The grantor-trustee ¹
b. So-called trust account that is not a legal or valid trust under state law	The actual owner ¹
6. Sole proprietorship or disregarded entity owned by an individual	The owner ³
7. Grantor trust filing under Optional Filing Method 1 (see Regulations section 1.671-4(b)(2)(i)(A))**	The grantor*

For this type of account:	Give name and EIN of:
8. Disregarded entity not owned by an individual	The owner
9. A valid trust, estate, or pension trust	Legal entity ⁴
10. Corporation or LLC electing corporate status on Form 8832 or Form 2553	The corporation
11. Association, club, religious, charitable, educational, or other tax-exempt organization	The organization
12. Partnership or multi-member LLC	The partnership
13. A broker or registered nominee	The broker or nominee
14. Account with the Department of Agriculture in the name of a public entity (such as a state or local government, school district, or prison) that receives agricultural program payments	The public entity
15. Grantor trust filing Form 1041 or under the Optional Filing Method 2, requiring Form 1099 (see Regulations section 1.671-4(b)(2)(i)(B))**	The trust

¹ List first and circle the name of the person whose number you furnish. If only one person on a joint account has an SSN, that person's number must be furnished.

² Circle the minor's name and furnish the minor's SSN.

³ You must show your individual name on line 1, and enter your business or DBA name, if any, on line 2. You may use either your SSN or EIN (if you have one), but the IRS encourages you to use your SSN.

⁴ List first and circle the name of the trust, estate, or pension trust. (Do not furnish the TIN of the personal representative or trustee unless the legal entity itself is not designated in the account title.)

* **Note:** The grantor must also provide a Form W-9 to the trustee of the trust.

** For more information on optional filing methods for grantor trusts, see the Instructions for Form 1041.

Note: If no name is circled when more than one name is listed, the number will be considered to be that of the first name listed.

Secure Your Tax Records From Identity Theft

Identity theft occurs when someone uses your personal information, such as your name, SSN, or other identifying information, without your permission to commit fraud or other crimes. An identity thief may use your SSN to get a job or may file a tax return using your SSN to receive a refund.

To reduce your risk:

- Protect your SSN,
- Ensure your employer is protecting your SSN, and
- Be careful when choosing a tax return preparer.

If your tax records are affected by identity theft and you receive a notice from the IRS, respond right away to the name and phone number printed on the IRS notice or letter.

If your tax records are not currently affected by identity theft but you think you are at risk due to a lost or stolen purse or wallet, questionable credit card activity, or a questionable credit report, contact the IRS Identity Theft Hotline at 800-908-4490 or submit Form 14039.

For more information, see Pub. 5027, Identity Theft Information for Taxpayers.

Victims of identity theft who are experiencing economic harm or a systemic problem, or are seeking help in resolving tax problems that have not been resolved through normal channels, may be eligible for Taxpayer Advocate Service (TAS) assistance. You can reach TAS by calling the TAS toll-free case intake line at 877-777-4778 or TTY/TDD 800-829-4059.

Protect yourself from suspicious emails or phishing schemes.

Phishing is the creation and use of email and websites designed to mimic legitimate business emails and websites. The most common act is sending an email to a user falsely claiming to be an established legitimate enterprise in an attempt to scam the user into surrendering private information that will be used for identity theft.

The IRS does not initiate contacts with taxpayers via emails. Also, the IRS does not request personal detailed information through email or ask taxpayers for the PIN numbers, passwords, or similar secret access information for their credit card, bank, or other financial accounts.

If you receive an unsolicited email claiming to be from the IRS, forward this message to phishing@irs.gov. You may also report misuse of the IRS name, logo, or other IRS property to the Treasury Inspector General for Tax Administration (TIGTA) at 800-366-4484. You can forward suspicious emails to the Federal Trade Commission at spam@uce.gov or report them at www.ftc.gov/complaint. You can contact the FTC at www.ftc.gov/idtheft or 877-IDTHEFT (877-438-4338). If you have been the victim of identity theft, see www.IdentityTheft.gov and Pub. 5027.

Go to www.irs.gov/IdentityTheft to learn more about identity theft and how to reduce your risk.

Privacy Act Notice

Section 6109 of the Internal Revenue Code requires you to provide your correct TIN to persons (including federal agencies) who are required to file information returns with the IRS to report interest, dividends, or certain other income paid to you; mortgage interest you paid; the acquisition or abandonment of secured property; the cancellation of debt; or contributions you made to an IRA, Archer MSA, or HSA. The person collecting this form uses the information on the form to file information returns with the IRS, reporting the above information. Routine uses of this information include giving it to the Department of Justice for civil and criminal litigation and to cities, states, the District of Columbia, and U.S. commonwealths and territories for use in administering their laws. The information may also be disclosed to other countries under a treaty, to federal and state agencies to enforce civil and criminal laws, or to federal law enforcement and intelligence agencies to combat terrorism. You must provide your TIN whether or not you are required to file a tax return. Under section 3406, payors must generally withhold a percentage of taxable interest, dividends, and certain other payments to a payee who does not give a TIN to the payor. Certain penalties may also apply for providing false or fraudulent information.

RFB Exceptions

Bidder's Name: _____

List any exceptions to the RFB below, including the Sample Contract. Provide a summary discussion of reasons for proposed exceptions and include any proposed alternative language. Any exceptions to the RFB will be considered and included in SWACO's evaluation. SWACO is not obligated to accept the requested exceptions, but failure to list the exception will prevent Bidder from raising it during contract negotiations.

List Exceptions Below.

--

Local, Certified, Equal Opportunity, and Green

SWACO is interested in contracting with companies that either meet the Local, Certified Business, Equal Opportunity Employer, and/or Environmentally Friendly classification descriptions below, and/or companies that have supplier equality programs that encompass local and/or certified companies. Please read each description below and complete the Acknowledgment form.

Local Business – Local businesses that meet the eligibility requirements as stated in the following paragraphs below, qualify as a Local Vendor:

- i. a domestic corporation, sole proprietorship, partnership, or joint venture that has its principal place of business located within Franklin County, Ohio or a county contiguous to Franklin County, Ohio ("Contiguous County") as registered in official documents filed with the Secretary of State, State of Ohio or the Franklin County Ohio recorder's office or a Contiguous County's recorder's office; or
- ii. a domestic corporation, sole proprietorship, partnership, or joint venture that holds a valid vendor's license which indicates its principal place of business is located within Franklin County or Contiguous County; or
- iii. a domestic corporation, sole proprietorship, partnership, or joint venture that employs more than 100 employees in Franklin County, Ohio and/or a county contiguous to Franklin County, Ohio; or
- iv. a domestic corporation, sole proprietorship, partnership, or joint venture that has more than fifty percent (50%) of its total employment located within Franklin County, Ohio and/or a county contiguous to Franklin County, Ohio.

Certified Business – Any business who is certified through any of the following certification programs are considered a Certified Business:

- i. City of Columbus; or
- ii. State of Ohio's Minority Business Enterprise (MBE), Veteran Business Enterprise (VBE), Women Business Enterprise (WBE), Minority Women Business Enterprise (MWBE), LGBT Business Enterprise (LGBTBE), Small Business Enterprise (SBE); or
- iii. Encouraging Diversity Growth and Equity (EDGE) program; or
- iv. Federal Disadvantaged Business Enterprise (DBE) program.

Equal Opportunity Employer – A business that agrees not to discriminate against any employee or job applicant because of race, color, religion, national origin, military status, sex, physical or mental disability, or age and has implemented equal opportunity employment practices in place.

Green/Environmentally Friendly – A business that has a verified green business program in place that reduces or minimizes the impact of waste, causing no harm to ecosystems or the environment. Vendors must provide documentation of the Green Business program to qualify as Environmentally Friendly, such as the GreenSpot Certificate of Membership from The City of Columbus.

****** If you qualify as a **Local, Certified, Equal Opportunity, or Environmentally Friendly** business, as described, please include supporting documentation affirming said characteristic and include with the *Acknowledgment* form:

ACKNOWLEDGEMENT

Thank you for your interest in SWACO! As a government agency, SWACO is requesting the additional information below to assist in delivering transparency and fairness to vendors by identifying contractor characteristics. The information you supply assists SWACO in promoting equitable practices and aligns with SWACO's Guiding Principles (<https://www.swaco.org/182/Vision-Mission-Goals>).

Please review the classifications below, check the appropriate box, and **attach** any certifications, evidence of being a Local or Certified business, an Equal Opportunity Employer, and/or Environmentally Friendly.

Local Business

Any contractor / business that is a domestic corporation, sole proprietorship, partnership, or joint venture that has its principal place of business located within Franklin County, Ohio or a county contiguous to Franklin County, Ohio ("Contiguous County") and that Vendor...

_____ has filed its official documents with the Secretary of State, State of Ohio or the Franklin County Ohio recorder's office or a Contiguous County's recorder's office.

_____ holds a valid vendor's license which indicates its principal place of business is located within Franklin County or Contiguous County.

_____ employs more than one hundred (100) employees in Franklin County, Ohio and/or a county contiguous to Franklin County, Ohio.

_____ has more than fifty percent (50%) of its total employment located within Franklin County, Ohio and/or a county contiguous to Franklin County, Ohio.

Certified Business

Any contractor / business that is certified through one of the following programs:

_____ Certified through the City of Columbus.

_____ State of Ohio's Minority Business Enterprise (MBE), Encouraging Diversity Growth and Equity (EDGE), Veteran Business Enterprise (VBE), Women Business Enterprise (WBE), Minority Women Business Enterprise (MWBE), LGBT Business Enterprise (LGBTBE), Small Business Enterprise (SBE), or Federal Disadvantaged Business Enterprise (DBE).

Equal Opportunity Employer

_____ A contractor / business that agrees not to discriminate against any employee or job applicant because of race, color, religion, national origin, military status, sex, physical or mental disability, or age and has implemented equal opportunity employment practices in place.

Environmentally Friendly

_____ A contractor / business that has a verified green business program in place that reduces or minimizes the impact of waste, causing no harm to ecosystems or the environment. Vendors must provide documentation of the Green Business program to qualify as Environmentally Friendly, such as the GreenSpot Certificate of Membership from The City of Columbus.

None

_____ Vendor is not a Local Business, Certified Business, Equal Opportunity Employer, or Environmentally Friendly.

Printed Vendor Name

Representative's E-Mail Address

Vendor Representative's Signature

Representative's Telephone Number

Printed Vendor Representative's Name

Exhibit C

Sample Contract and Sample Contract Forms

Sample Contract

The following Sample Contract contains SWACO's standard terms and conditions provided for review.

Any exceptions to the RFB or this Sample Contract must be noted in the *Exceptions to RFB* form included with the Required Forms in Exhibit B.

CONTRACT FOR CONSTRUCTION SERVICES

This Agreement is by and between the Solid Waste Authority of Central Ohio, ("SWACO"), a regional solid waste district established pursuant to Ohio Revised Code Section 343.011 with a business address of 4239 London-Groveport Road, Grove City, Ohio 43123, and [SELECTED VENDOR] ("Contractor"), located at [SELECTED VENDOR ADDRESS].

NOW, THEREFORE, in consideration of the mutual promises herein contained, SWACO and Contractor agree as follows:

1. Term. The term of this Contract shall commence on [START DATE] and shall terminate on [END DATE] ("Contract Times"). For multi-year contracts, SWACO's funds are contingent upon the approval of the annual budget by the Board of Trustees. If SWACO's Board of Trustees fails at any time to continue funding for the payments or any other obligations due by SWACO under this Contract, SWACO will be released from its obligations on the date the funding expires. This Contract may be terminated by SWACO for any or no reason upon delivery by first class U.S. mail, postage prepaid, or delivery by hand, of a written "Notice of Termination" to Contractor at least fifteen (15) days prior to the date of the intended early termination of this Contract.

1.1. The Work to be performed under this Contract shall be completed within the established Contract Times. Contractor shall begin the Work of the Project upon written instruction by SWACO. As established in the Milestone schedule, the date of Work Complete and Ready for Final Payment shall not be later than the termination date listed above. Additionally, Substantial Completion for the Work for the Project, including final cleanup and resolution of any punch list items, shall be completed prior to the date of Work Complete and Ready for Final Payment.

1.2. *Non-Exclusivity of Contract*. Contractor understands and agrees that this Contract for the provision of Services is not intended to be, nor shall it be construed to be, an exclusive Contract with SWACO for the provision of the type of Services set forth in this Contract.

1.3. *Level of Services Requested*. SWACO is not required by this Contract to request any Services, or a minimum amount of Services, from the Contractor.

2. Scope of Services. Contractor shall provide all services in accordance with the terms, conditions, and provisions as set forth in this Contract, the Request for Bid attached hereto as Exhibit A and Contractor's Bid attached hereto as Exhibit B, all of which are incorporated herein by reference as if fully rewritten (collectively "Services"). Contractor shall perform all Services in accordance with the terms, conditions, and provisions set forth in this Contract and the attached exhibit(s).

2.1. *Standard of Care*. Contractor shall perform all Services in accordance with professional standards of skill, care, and diligence for Contractor's profession and in

accordance with pertinent provisions of the Ohio Revised Code, the Ohio Administrative Code, federal and/or local statutes, ordinances, rules, and regulations.

2.2. *Acceptance or Rejection of Services.* SWACO may, in its sole and complete discretion, accept or reject any portion of the Services provided by Contractor. In the event that any portion of the Services is rejected by SWACO, Contractor shall proceed, upon SWACO's request, with correcting any such rejected Services to the reasonable satisfaction of SWACO. The review or acceptance by SWACO of any Services performed by Contractor pursuant to this Contract shall not relieve Contractor of its responsibility to perform such Services pursuant to the terms and conditions of this Contract.

3. Contractor Compensation. At the rates set forth in Exhibit B, SWACO shall pay Contractor for the Services performed, and any additional services as mutually agreed in writing, an amount not to exceed \$[PROJECTED TOTAL AMOUNT]. Compensation shall be inclusive of all costs associated with Contractor providing Services.

3.1. Upon completion of any Service by Contractor and acceptance by SWACO, Contractor shall submit to SWACO an invoice setting forth the total number of hours of Services provided; the hourly rates for the Services rendered; the specific nature of the Services rendered; and, any other items for which compensation is sought.

3.2. All invoices should be submitted to SWACO within sixty (60) days after Services have been rendered and shall state SWACO's project and purchase order numbers, both of which are set forth on page one (1) of this Contract. SWACO shall pay such invoice within thirty (30) days of its approval by SWACO. However, regardless of when payment is made, and notwithstanding any terms set forth on the invoice and/or any other document to the contrary, SWACO shall never be obligated or liable to Contractor and/or any other party for any late payment or collection costs, fees, or interest charges.

3.3. Notwithstanding any term, condition, or provision set forth in this Contract and/or any other document to the contrary, the total monetary obligation of SWACO under this Contract shall never exceed the total sum of \$[PROJECTED TOTAL AMOUNT].

4. Contractor Duty to Indemnify SWACO. To the fullest extent permitted by law, Contractor shall indemnify SWACO as follows:

4.1 *Environmental Indemnification.* Contractor shall save, indemnify, and hold harmless SWACO, its Board of Trustees, employees, agents, officers, employees, and representatives from and against any and all liabilities, claims, demands, causes of action, penalties, judgments, forfeitures, liens, suits, costs, and expenses whatsoever, including those arising out of death, injury to persons, or damage to or destruction of property, and the cost and expenses incident thereto (including reasonable attorney's fees) resulting from contamination of or adverse effects on the environment, or any violation of governmental laws, regulations, or orders, in each case, to the extent caused by Contractor's performance of Services or its operations as contemplated by the Services as said relates to the FCSL, Model Landfill, or any other SWACO facility. SWACO shall promptly notify Contractor of any assertion of any claim against it for which it is entitled to be indemnified hereunder and shall give Contractor the opportunity to defend such claim.

4.2. *General Duty to Indemnify SWACO.* Contractor shall indemnify and hold harmless SWACO, its Trustees, officers, employees, and representatives from and against all claims, damages, losses, liens, causes of action, suits, judgments, and expenses (including reasonable attorney's fees and other reasonable costs of defense), of any nature, kind, or description, which (a) are caused by or result from the performance of the Services by Contractor, anyone directly or indirectly employed by Contractor, any subcontractor of Contractor, or anyone for whose acts Contractor is legally liable, and (b) are attributable to bodily injury, personal injury, sickness, disease, or death of any person, or to damage to or destruction of property, but (c) only to the extent they are caused by any negligent, reckless, or willful act, error, or omission of Contractor, anyone directly or indirectly employed by Contractor, any subcontractor of Contractor, or anyone for whose acts Contractor is legally liable. The terms, conditions, and provisions of this paragraph 4.3 shall survive the termination of this Contract for any reason.

4.3. *Correction, Repair, or Replacement of Insured Losses.* Contractor shall promptly correct, repair, and/or replace any items, work, and/or materials installed as part of the Services and damaged and/or destroyed as a result of an insured loss or damage. Such correction, repair, and/or replacement shall be Contractor's sole responsibility and shall be undertaken and completed at no additional cost to SWACO.

5. Operational Covenants. Contractor shall conduct its activities under this Contract in such a manner as not to unreasonably interfere with SWACO's use of the Franklin County Sanitary landfill ("FCSL") and/or any other SWACO facilities. Any such noise, odor, or other environmental impact levels produced by Contractor as a result of its operations or performance of the Services shall not cause a nuisance to the surrounding community, nor shall such noise, odor, or other environmental impact levels exceed, at the boundaries of the FCSL or Model Landfill, applicable State or local standards for noise, odor, or environmental impact levels. Contractor shall promptly mitigate any noise, odor, or other environmental impacts caused by its operations or performance of the Services which result in violations of law or meritorious complaints to SWACO. Contractor shall further operate any SWACO facility systems and/or any SWACO-supplied equipment in a prudent manner in accordance with sound engineering practices and in a manner consistent with that used by industry specialists providing same or similar services, as well as all applicable federal, State, and local laws, rules, ordinances, and regulations. Contractor agrees to maintain those facility systems for which its Services are contemplated under this Contract, as well as all associated SWACO-purchased equipment, in good working order throughout the term of this Contract.

6. Environmental Matters. Contractor shall construct, operate, and maintain any and all compliance related equipment, and shall otherwise conduct its activities hereunder, in full conformance with all applicable Environmental Laws and associated permits and shall timely provide copies of all documentation pertaining to compliance with Environmental Laws and permits, which documentation shall include but not be limited to correspondence to and from any governmental authority, compliance reporting and related data generated, permit applications, requests for waiver or exemption from any governmental authority, and/or notice(s) of violations received from any person, agency, or authority. Contractor further agrees to comply with all applicable federal, State and local laws, including Environmental Laws, rules, permits, ordinances, and regulations relating to or regulating the construction, operation, and/or performance of the Services relating to the FCSL or Model Landfill.

7. Contractor Liability Insurance. Contractor shall purchase and maintain the following liability and other insurance at the indicated limits and under the terms set forth below:

- 7.1. *General Liability Insurance*, containing the following limits and terms:
 - 7.1.1. \$1,000,000.00 per occurrence
 - 7.1.2. \$2,000,000.00 aggregate
 - 7.1.3. \$1,000,000.00 Products/Completed Operations Aggregate
 - 7.1.4. Name SWACO as an additional insured
 - 7.1.5. Waiver of subrogation in favor of SWACO and all related entities or subsidiaries, employees, agents and/or representatives

- 7.2. *Automobile Liability Insurance*, containing a limit of \$1,000,000.00 per occurrence.

- 7.3. *Worker's Compensation and Employer's Liability Insurance*, containing the following limits:
 - 7.3.1. Statutory Limits for the State of Ohio
 - 7.3.2. \$500,000.00/\$500,000.00/\$500,000.00 Employer's Liability Limit

- 7.4. *Professional Liability Insurance* covering errors, omissions, and/or negligence of Contractor with a coverage limit of \$5,000,000.00

- 7.5. *Umbrella Liability Insurance* containing the following limits and terms:
 - 7.5.1. \$2,000,000.00 per occurrence
 - 7.5.2. Following Form Coverage

- 7.6. Each policy of insurance required to be purchased and maintained by Contractor shall:
 - 7.6.1. Be purchased from an insurance carrier rated by A.M. Best as A-, VII or better;
 - 7.6.2. Each policy and respective certificate of insurance shall expressly provide that should Contractor's insurance lapse, be cancelled, non-renewed or materially altered, Contractor shall provide SWACO with no less than thirty (30) days prior written notice of such cancellation, non-renewal, expiration or material alteration of the coverage contained in such policy or evidenced by such certificate of insurance; and
 - 7.6.3. Within fifteen (15) days of the execution of this Contract by SWACO's Executive Director or his designee, Contractor shall without demand furnish SWACO with a certified copy of any insurance certificate and/or additional insured endorsement required to be purchased or maintained by Contractor under the terms of this Contract. Failure of Contractor to comply with the terms and conditions of this paragraph shall constitute a material breach of this Contract and shall be cause for termination of this Contract by SWACO.

- 7.7. Contractor shall maintain all insurance in the required amounts, without interruption, from the date of the execution of this Contract until the date of the termination of this Contract or the date of payment of the final invoice issued by Contractor, whichever is later. Failure of Contractor to comply with the terms and conditions of this paragraph shall constitute a material breach of this Contract and shall be cause for termination of this Contract by SWACO.

- 7.8. Insurance policies required to be purchased and maintained by Contractor may include a reasonable loss deductible, as is customary for the Contractor's industry, which shall be the sole responsibility of Contractor to pay in the event of any covered loss.
- 7.9. SWACO and Contractor waive all rights against each other for damages caused by fire or other perils to the extent of actual recovery of any insurance proceeds under any property insurance obtained pursuant to the requirements set forth above or any other property insurance applicable to the performance of the Services, except such rights as they have to proceeds of such insurance held by SWACO as fiduciary. Contractor agrees to obtain waivers in favor of SWACO of such claims by all of its subcontractors.
- 7.10. Notwithstanding paragraph 7.9 above, and regardless of the amount of any insurance proceeds recovered by the parties under the insurance policies set forth above, Contractor shall be liable to SWACO for the full amount of any claims, damages, losses, liens, causes of action, suits, judgments, and expenses, including reasonable attorney's fees and other reasonable costs of defense, of any nature, kind, or description which are in excess of such insurance proceeds.
8. Entire Contract. This Contract and the attached exhibit(s) represent the entire and integrated contract between SWACO and Contractor and supersede all prior negotiations, representations, agreements, or contracts, either written or oral, between the parties hereto.
9. Effect of Captions. The captions or headings in this Contract are for convenience only and in no way define, limit, or describe the scope or intent of any terms, conditions, provisions, or sections hereof.
10. No Personal Liability of SWACO Officials. Neither SWACO's Board of Trustees, either individually or collectively, nor any SWACO official executing this Contract or any modification hereto shall be subject to any personal liability by reason of such execution.
11. Contract Binding on Successors and Assigns. SWACO and Contractor each bind themselves, their successors, assigns, and legal representatives to the other party to this Contract.
12. No Third Party Interest. No person or corporation other than Contractor and SWACO have any interest hereunder and no claim shall be made or be valid, nor shall any term, condition, provision, or covenant herein be construed so as to give any person other than the parties hereto any legal or equitable right, remedy, or claim under or in respect to this Contract.
13. Assignment by Contractor. Contractor shall not assign or transfer any right, title, or interest in this Contract without the prior written consent of SWACO, which consent may be withheld by SWACO for any or no reason.
14. Construction of Contract Terms. If any paragraph, term, condition, or provision of this Contract is determined by a court of competent jurisdiction to be invalid or unenforceable, such determination shall not affect the validity or enforceability of any other paragraph, term, condition, or provision of this Contract, each of which shall be construed and enforced to the fullest extent of the law as if such invalid or unenforceable paragraph, term, condition, or provision were not contained herein.

15. Negotiation of Contract Terms, Conditions, and Provisions. The parties acknowledge and recognize that each of them participated materially in the negotiation and drafting of this Contract and had access to legal counsel during its negotiation and drafting.
16. Applicable Law; Venue. The laws of the State of Ohio, without regard to its own “choice of law” provisions, shall govern to the exclusion of the laws of any other jurisdiction in the interpretation and application of the terms, conditions, and provisions of this Contract. Any action or proceeding pertaining to this Contract shall be heard in a court of law having appropriate jurisdiction located in Franklin County, Ohio.
17. Delinquent Personal Property Tax Affidavit. The Delinquent Personal Property Tax Affidavit executed contemporaneously by Contractor with the execution of this Contract is incorporated herein by reference as if fully rewritten.
18. Contractor is Independent Contractor. Nothing contained in this Contract is intended to be, or shall be, construed to create or establish the relationship of a partnership, joint venture, or other business organization between the parties hereto nor to create an agency, representative, or employment relationship between Contractor or its employees and SWACO. Neither Contractor nor its employees shall be considered an employee of SWACO nor shall they acquire or be entitled to any compensation, rights, benefits, and/or participation of any kind whatsoever offered by SWACO including, without limitation, participation in the Ohio Public Employees Retirement System, worker’s compensation coverage and/or benefits, medical and hospital care, sick and vacation leave, unemployment compensation, disability, and severance pay.
19. Compliance with Law. By executing this Contract, Contractor acknowledges that it is in compliance with all federal, State, municipal and/or other local laws, ordinances, resolutions, rules, and regulations that govern this Contract and its performance including, without limitation, Ohio Revised Code section 3517.13, divisions (I) and (J).
20. Non-Discrimination. Contractor agrees that during the performance of this Contract, Contractor and any subcontractor shall not discriminate against any employee or qualified applicant for employment who is both available and qualified for work because of age, race, color, religion, sex, disability, creed, or national origin. Contractor and any subcontractor shall not discriminate based upon age, race, color, religion, sex, disability, creed, or national origin in any undertaking related to employment including, but not limited to, such actions as hiring, upgrading, demotion or transfer, recruitment or recruitment advertising, layoff or termination, rates of pay or other forms of compensation, and selection for training, including apprenticeship.
21. Contract Modification. This Contract may be modified by a writing signed by the Contractor and SWACO’s Executive Director, pursuant to SWACO’s procurement policy.
22. Employment Taxes. Each party will be solely responsible for reporting, withholding and/or paying all employment related taxes, payments and/or withholdings for its own personnel, including, but not limited to, federal, State, and local income taxes, social security, unemployment or disability deductions, withholdings, and/or payments, together with any interest and penalties not disputed with the appropriate taxing authority.

23. Sales, Use, Excise, and Property Tax. SWACO is exempt from any sales, use, excise, and property tax. To the extent sales, use, excise, or any similar tax is imposed on the Contractor in connection with the Scope of Services, such will be the sole and exclusive responsibility of the Contractor, and the Contractor will pay such taxes, together with any interest and penalties not disputed with the appropriate taxing authority, whether they are imposed at the time the services are rendered or a later time.

24. Drug-Free Workplace. Contractor will comply with all applicable State and federal laws regarding keeping a drug-free workplace. Contractor will make a good faith effort to ensure that all Contractor's employees, while working on SWACO property, will not have or be under the influence of illegal drugs, alcohol, or abuse prescription drugs in any way.

25. No Waiver. Either party's failure to enforce any provision or term of this Contract shall not be construed as a future or continuing waiver of such provision or term of this Contract.

26. Additional Terms and Conditions. SWACO and Contractor have included additional terms and conditions specific to this Contract as set forth and described in the exhibit(s) and incorporated herein by reference as if fully rewritten. In the event of a conflict between the exhibit(s) and the standard terms and conditions as provided in Section 1 through Section 28, the standard terms and conditions in Sections 1 through 28 shall prevail.

27. Signatures. The parties agree that facsimile, electronic, or scanned signatures shall be acceptable and shall have the same effect as original signatures.

28. Effective Date. This Contract shall become effective on the date as set forth herein.

Signature Page Follows

IN WITNESS WHEREOF, the parties hereto have executed this Contract on the dates set forth below.

**SWACO:
Solid Waste Authority of Central Ohio**

By: _____
Joseph A. Lombardi, Executive Director

Date: _____

**Contractor:
[SELECTED VENDOR]**

By: _____
*Authorized Signature

Date: _____

*By signing above, you represent and warrant that you have the full power and authority to execute this Agreement on behalf of the Contractor, and bind the Contractor to this Agreement, as well as the terms, conditions and obligations set forth herein.

Approved as to Form:

Rebecca L. Egelhoff, Director of Legal Affairs
Solid Waste Authority of Central Ohio

Date: _____

Exhibit C

Sample Contract and Contract Forms (*Continued*)

Contract Forms

- A. Supplementary Conditions
- B. Notice of Award
- C. Notice to Proceed
- D. Notice of Commencement of Public Improvement
- E. Field Work Order
- F. Change Order
- G. Certificate of Substantial Completion
- H. Partial Release and Waiver of Lien
- I. Final Release and Waiver of Lien
- J. Release of Lien



**SUPPLEMENTARY CONDITIONS
FOR SWACO FACILITIES CONSTRUCTION**
(Paragraphs keyed to the SWACO's General Conditions)

**[INSERT PROJECT NAME]
[DATE OF PROJECT]**

INSERT SUPPLEMENTARY CONDITIONS AS NECESSARY.

SAMPLE

NOTICE OF AWARD

[DATE]

[CONTRACTOR NAME]
[CONTRACTOR ADDRESS]
[CITY, STATE ZIP]

RE: [PROJECT NAME]

Dear Mr./Ms. [NAME]:

You are hereby notified that the Solid Waste Authority of Central Ohio (herein called “SWACO”), has reviewed all Bids submitted for [NAME OF PROJECT].

In accordance with the Bid Documents prepared for [INSERT PROJECT NAME], your Bid in the amount of \$[INSERT DOLLAR AMOUNT] has been accepted. SWACO intends to execute the Contract for this Project, provided, however, that you comply with the obligations of the Successful Bidder set forth in the SWACO General Conditions. Acceptance by SWACO is conditioned upon your compliance with those obligations and SWACO reserves the right to refrain from entering into or to rescind the contract if you do not fulfill those obligations within the respective times specified.

All required Bonds and Certificates of Insurance, in accordance with Article III of the SWACO General Conditions, shall be submitted to SWACO within fifteen (15) calendar days of the date of this Notice of Award for review and approval.

Subsequent to execution of the contract by SWACO, one (1) copy of the fully executed Agreement will be returned to you.

SOLID WASTE AUTHORITY OF CENTRAL OHIO

By: _____
[PRINTED NAME]
[TITLE]

NOTICE TO PROCEED

[DATE]

[CONTRACTOR]

[ADDRESS OF CONTRACTOR]

RE: [PROJECT NAME]

Dear Mr./Ms. [NAME]

You are hereby notified to commence Work in accordance with the Contract dated _____, 20____, on or before _____, 20____. Contractor shall complete the work in accordance with the dates for each milestone in the Contract, repeated below for reference only. Liquidated damages in the amount contained in the Contract for each calendar day the work remains incomplete after its associated milestone date will be imposed unless the Contract Times are otherwise adjusted for due cause by Change Order to the Contract.

MILESTONE	MILESTONE DATE
Substantial Completion of Work	[DATE]
Work Complete and Ready for Final Payment	[DATE]

SOLID WASTE AUTHORITY OF CENTRAL OHIO

By: [PROJECT MANAGER NAME AND TITLE]

NOTICE TO PROCEED

Page Two

ACCEPTANCE OF NOTICE

Receipt of the above NOTICE TO PROCEED is hereby acknowledged by [NAME OF CONTRACTOR] this _____ day of _____, 20____.

By: _____
(Signature of Officer)

(Print Name and Title of Officer)

Notice of Commencement of Public Improvement

Solid Waste Authority of Central Ohio
4239 London Groveport Road, Grove City, Ohio 43123
Phone: (614) 871-5100 • Fax: (614) 871-5103

Notice is hereby given in accordance with Section 1311.252 Ohio Revised Code of the commencement of the Public Improvement identified as:

Project Name _____	Public Owner Solid Waste Authority of Central Ohio
_____	4239 London Groveport Road
Project Location _____	Grove City, Ohio 43123
County _____	_____

Public Authority

The Public Authority responsible for the public improvement is:

Solid Waste Authority of Central Ohio
4239 London Groveport Road
Grove City, Ohio 43123

Designated Representative

The representative to whom service of an affidavit may be made pursuant to Section 1311.26 Ohio Revised Code is:

Mr. Joseph A. Lombardi, Executive Director
Solid Waste Authority Of Central Ohio
4239 London Groveport Road
Grove City, Ohio 43123

Affidavit

I certify or affirm that to the best of my knowledge, the information provided in this document is true and correct and that I am fully authorized to provide this Notice.

Affiant:

Solid Waste Authority of Central Ohio

Joseph A. Lombardi, Executive Director

Notary

The Affiant acknowledged and signed this instrument before me, a Notary Public in and for the County of _____, Ohio.

[Seal] Sworn and subscribed before me this _____ day of _____, 20____.

Notary Public
My commission expires _____

Notice of Commencement of Public Improvement *(Continued)*

Solid Waste Authority of Central Ohio
4239 London-Groveport Road, Grove City, Ohio 43123
Phone: (614) 871-5100 ♦ Fax: (614) 871-5103

Project Information

Project Name _____

Project Location _____

County _____

Contractor (attached additional pages as necessary)

Surety

Name _____

Address _____

City, State, Zip _____

Trade _____

Contract _____

Execution Date _____

Name _____

Address _____

City, State, Zip _____

Name _____

Address _____

City, State, Zip _____

Trade _____

Contract _____

Execution Date _____

Name _____

Address _____

City, State, Zip _____

Name _____

Address _____

City, State, Zip _____

Trade _____

Contract _____

Execution Date _____

Name _____

Address _____

City, State, Zip _____

Name _____

Address _____

City, State, Zip _____

Trade _____

Contract _____

Execution Date _____

Name _____

Address _____

City, State, Zip _____

Name _____

Address _____

City, State, Zip _____

Trade _____

Contract _____

Execution Date _____

Name _____

Address _____

City, State, Zip _____



FIELD WORK ORDER

[Name of Project]

FIELD WORK ORDER NO. _____

TO: _____
(Contractor's Name)

(Contractor's Address)

(Contractor's Address)

ATTN: _____
(Contractor's Contact)

TITLE: _____

DESCRIPTION:

REASON:

Issued By: _____
(Name and Title)

Issued Date: _____



CONSTRUCTION CHANGE ORDER

NO. _____

CONTRACTOR: _____ PROJECT NAME _____

ADDRESS: _____ CONTRACT _____

DATE: _____

You are hereby authorized and directed to make the changes to your contract with the Solid Waste Authority of Central Ohio covering the above project, as described below:

Bid Item No.	Bid Item	Unit	Original			Revised		
			Quantities	Unit Price	Bid Price	Quantities	Unit Price	Bid Price
TOTAL					0.00			0.00

Description of Changes

Description of Changes

Justification for Change

Justification for Change

Additional Contract Days: (If none, state "NONE") NONE



CERTIFICATE OF SUBSTANTIAL COMPLETION

PROJECT: _____ [*Project Name*]

DATE OF ISSUANCE: _____

OWNER: Solid Waste Authority of Central Ohio (SWACO)

PROJECT NO.: _____

CONTRACTOR: _____

ENGINEER: _____

This Certificate of Substantial Completion applies to all Work under the Contract Documents or to the following specified parts thereof.

TO: Solid Waste Authority of Central Ohio
(OWNER)

And TO: _____
(CONTRACTOR)

The Work to which this Certificate applies has been inspected by authorized representatives of SWACO, CONTRACTOR and ENGINEER, and that Work is hereby declared to be substantially complete in accordance with the Contract Documents on **[INSERT DATE OF SUBSTANTIAL COMPLETION]**.

A tentative list of items to be completed or corrected is attached hereto. This list may not be all-inclusive, and the failure to include an item in it does not alter the responsibility of CONTRACTOR to complete all the Work in accordance with the Contract Documents. The items in the tentative list shall be completed or corrected by CONTRACTOR within _____ days of the above date of Substantial Completion.

From the date of Substantial Completion, the responsibilities between OWNER and CONTRACTOR for security, operation, safety, maintenance, heat, utilities, insurance and warranties and guarantees shall be as follows:

RESPONSIBILITIES

OWNER: _____

CONTRACTOR: _____

The following documents are attached to and made a part of this Certificate:

[For items to be attached, see definition of Substantial Completion as supplemented and other specifically noted conditions precedent to achieving Substantial Completion as required by Contract Documents.]

This certificate does not constitute an acceptance of Work not in accordance with the Contract Documents nor is it a release of Contractor's obligation to complete the Work in accordance with the Contract Documents.

Executed by ENGINEER on _____, 20____

ENGINEER

By: _____
Authorized Signature

CONTRACTOR accepts this Certificate of Substantial Completion _____, 20____

CONTRACTOR

By: _____
Authorized Signature

OWNER accepts this Certificate of Substantial Completion on _____, 20____

OWNER

By: _____
Authorized Signature

END OF CERTIFICATE OF SUBSTANTIAL COMPLETION



PARTIAL RELEASE AND WAIVER OF LIEN

STATE OF _____)
) SS:
COUNTY OF _____)

The undersigned, _____ (hereinafter referred to as "Contractor") hereby represents that on _____ it was awarded a Contract by the Solid Waste Authority of Central Ohio, 4239 London Groveport Road, Grove City, Ohio 43123 (hereinafter referred to as "Owner"), to construct the _____ in accordance with the terms and conditions of the Contract dated _____ 20____, and the undersigned further represents that all progress payments heretofore received from the Owner on account of the Work have been applied by the Contractor to discharge in full all of the Contractor's obligations incurred in connection with the Work covered by all prior Estimates.

This affidavit is freely and voluntarily given with full knowledge of the facts, on this _____ day of _____, 20____.

[NAME OF CONTRACTOR]

(Contractor)

By: _____

Title: _____

Subscribed and sworn to before me this _____ day of _____, 20____.

Notary Public

My commission expires _____



FINAL RELEASE AND WAIVER OF LIEN

STATE OF _____)
) SS:
COUNTY OF _____)

The undersigned, _____ hereby represents that on _____, he/it was awarded a contract by Solid Waste Authority of Central Ohio, 4329 London Groveport Road, Grove City, Ohio 43123 hereinafter called the Owner, to construct the _____ [PROJECT NAME] _____ in accordance with the terms and conditions of the Agreement dated _____, 20____; and the said contract has now been completed.

The undersigned hereby warrants and certifies that all of his (its) indebtedness arising by reason of the said contract has been fully paid or satisfactorily secured; and that all claims from subcontractors and others for labor and material used in accomplishing the said project, as well as all other claims arising from the performance of the said contract, have been fully paid or satisfactorily settled. The undersigned further agrees that, if any such claim should hereafter arise, he (it) shall assume responsibility for the same immediately upon request to do so by the Owner.

The undersigned, for a valuable consideration, the receipt of which is hereby acknowledged, does further hereby waive, release and relinquish any and all claims or right of lien which the undersigned now has or may hereafter acquire upon the subject premises for labor and material used in accomplishing said project owned by the Owner.

This affidavit is freely and voluntarily given with full knowledge of the facts, on this _____ day of _____, 20____.

(Contractor)

By _____

(Title)

Subscribed and sworn to before me this _____ day of _____, 20____.

Notary Public
My commission expires _____



RELEASE OF LIEN AFFIDAVIT

(To be completed by all Contractors, Subcontractors and Materialmen Pursuant to ORC Section 1311.26 to 1311.32)

STATE OF _____)
) SS:
COUNTY OF _____)

TO WHOM IT MAY CONCERN:

WHEREAS, the undersigned _____ has been employed has
(Contractor, Subcontractor or Materialmen)
been employed by _____ to furnish labor
(Prime Contractor / Owner)
and/or materials for _____ for the Project known
(Nature of the Work)
as [PROJECT NAME] at _____ in Franklin County, Ohio.

The last of said labor and/or materials was provided to the above described project on the _____ day of _____, 20____.

NOW, THEREFORE, KNOW YE, that the undersigned for and in consideration of the sum of _
[INSERT DOLLAR AMOUNT] dollars and other good
and valuable considerations, the receipt of which is hereby acknowledged, do hereby waive and release
any and all funds at any time heretofore or hereafter designated for use in connection with the above
described project, under the statutes of the State of Ohio relating to mechanics' liens, on funds for public
works, on account of labor or materials, or both, furnished by the undersigned to or on account of the said
firm or individual named for said building or premises.

Witness: _____

Witness: _____ By: _____

Title: _____

Subscribed and sworn to before me this _____ day of _____, 20____.

Notary Public
My commission expires _____

Exhibit D

006. SWACO General Conditions for Construction

Any exceptions to the SWACO General Conditions of the Contract for Construction must be noted in the *Exceptions to RFB* form included with the Required Forms in Exhibit B.



Solid Waste Authority of Central Ohio

General Conditions of the Contract for Construction

TABLE OF CONTENTS

I. DEFINITIONS.....	2	X. CHANGE OF CONTRACT TIMES	34
II. GENERAL PROVISIONS	7	XI. TESTS AND INSPECTIONS; CORRECTION, REMOVAL, OR ACCEPTANCE OF DEFECTIVE WORK.....	35
III. BONDS AND INSURANCE	13	XII. PAYMENTS TO COMPLETION	37
IV. CONTRACTOR’S RESPONSIBILITIES.....	16	XIII. SUSPENSION OF WORK AND TERMINATION	41
V. OTHER WORK.....	27	XIV. DISPUTE RESOLUTION	42
VI. OWNER’S RESPONSIBILITIES.....	28	XV. AUDITS AND RECORDS EXAMINATION	43
VII. ENGINEER’S STATUS DURING CONSTRUCTION	28	XVI. PREVAILING WAGE PAYROLL SUBMITTALS	43
VIII. CHANGES IN THE WORK	30	XVII. MISCELLANEOUS	44
IX. CHANGE OF CONTRACT PRICE.....	31		

ARTICLE I DEFINITIONS

Wherever used in these General Conditions or in the other Contract Documents, the following terms have the following meanings indicated which are applicable to both the singular and plural thereof:

1.1 Addenda – Written or graphic instruments issued prior to the opening of Bids, which clarify, correct, or change the Bidding Requirements or the Contract Documents.

1.2 Administrative Costs – Includes compensation paid to Contractor's officers, executives, principals, general managers, engineers, architects, estimators, attorneys, auditors, accountants, purchasing, and contracting agents, expeditors, timekeepers, clerks, and other personnel employed by Contractor, whether at the Project or in Contractor's principal or branch office, and other expenses for general administration of the Work.

1.3 Agreement – The written contract between SWACO and Contractor covering the Work to be performed; other Contract Documents are attached to the Agreement and made a part thereof as provided therein.

1.4 Alternate – A proposed change in the Work described in the Contract Documents providing alternative materials, products or systems, or to add or delete portions of the Work.

1.5. Application for Payment – The form accepted by Engineer which is to be used by Contractor in progress or final payments and which is to be accompanied by such supporting documentation as is required by the Contract Documents.

1.6 Asbestos – Any material that contains more than one percent (1%) asbestos and is friable or is releasing asbestos fibers into the air above current action levels established by the United States Occupational Safety and Health Administration.

1.7 As-Built Drawings – Drawings or computer files revised by the Contractor to show changes made during the construction process.

1.8 Bid – The offer or proposal of the bidder submitted on the prescribed form setting forth the prices for the Work to be performed.

1.9 Bidding Documents – The advertisement or invitation to Bid, instructions to bidders, the Bid form, and the proposed Contract Documents (including all Addenda issued prior to receipt of Bids).

1.10 Bidding Requirements – The advertisement or invitation to Bid, instructions to bidders, and the Bid form.

1.11 Board – The Board shall be defined as the Solid Waste Authority of Central Ohio Board of Trustees.

1.12 Bonds – Performance and Payment bonds and other instruments of security.

1.13 Change Order – A document recommended by Engineer, which is signed by Contractor and SWACO and authorizes an addition, deletion, or revision in the Work, or an adjustment in the Contract Price or the Contract Times, issued on or after the Effective Date of the Agreement. No Change Order, or part thereof, that increases the Contract Price or provides for the expenditure of money for Work or other items or services not set-forth in the Contract Documents shall be effective unless such Change Order has been authorized by SWACO's Board of Trustees pursuant to SWACO's By-Laws and Procurement Policy. SWACO shall have no liability to pay Contractor for Work or other items or services performed or provided as the result of a Change Order which has not been authorized by SWACO's Board of Trustees pursuant to SWACO's By-Laws and Procurement Policy.

1.14 Claim Affidavit – A claim on the funds that are due to a Contractor, created by statute in favor of a person supplying labor, materials or services for the value of labor, materials or services supplied by the claimant.

1.15 Construction Manager – The individual and/or firm indicated as such in the Contract. The Construction Manager is a member of the CMT, whose specific division of duties shall be defined by SWACO.

1.16 Construction Schedule – The schedule for the construction of the Project showing the time for completing the Work, the planned sequence for performing the Work, Milestones, the Contractor’s resource loading curve, and the interrelationship between the activities of the Contractors and SWACO.

1.17 Contract Completion – The date upon which all deficiencies noted in the Punch List have been corrected, the Contractor's Work is 100 percent complete, and the Contractor has complied with all conditions precedent to final payment and release of retainage.

1.18 Contract Documents – The Agreement, Addenda (which pertain to the Contract Documents), Contractor’s Bid (including documentation accompanying the Bid and any post Bid documentation submitted prior to the Notice of Award) when attached as an exhibit to the Agreement, the Notice to Proceed, the Bonds, these General Conditions, the Supplementary Conditions, the Specifications, and the Drawings as the same are more specifically identified in the Agreement, together with all Written Amendments, Change Orders, Work Change Directives, Field Orders, and Engineer’s written interpretations and clarifications issued pursuant to the provisions herein on or after the Effective Date of the Agreement. Shop Drawing submittals approved pursuant to the provisions herein and the reports and drawings as referred to in paragraph 2.3.5 are not Contract Documents.

1.19 Contract Price – The moneys payable by SWACO to Contractor for completion of the Work in accordance with the Contract Documents as stated in the Agreement, subject to the provisions governing Unit Price Work, if applicable.

1.20 Contract Times – The number of days or the dates stated in the Agreement to (i) achieve Substantial Completion, and (ii) complete the Work so that it is ready for final payment as evidenced by the Engineer’s written recommendation of final payment.

1.21 Contractor – The person, firm, or corporation with whom SWACO has entered into the Agreement.

1.22 Day – Calendar Day, unless otherwise expressly specified to mean a working Day.

1.23 Defective – An adjective which when modifying “Work” refers to Work that is unsatisfactory, faulty, or deficient, in that it does not conform to the Contract Documents, or does not meet the requirements of any inspection, reference standard, test, or approval referred to in the Contract Documents, or has been damaged prior to Engineer’s recommendation of final payment, unless responsibility for the protection thereof has been assumed by SWACO at Substantial Completion in accordance with paragraph 9.3 or as otherwise stated herein.

1.24 Drawings – The drawings which show the scope, extent, and character of the Work to be furnished and performed by Contractor and which have been prepared or approved by Engineer and are referred to in the Contract Documents. Shop Drawings are not Drawings so defined.

1.25 Effective Date of the Agreement – The date indicated in the Agreement on which it becomes effective, but if no such date is indicated it means the date on which the Agreement is signed and delivered by the of the two (2) parties to sign and deliver.

1.26 Engineer – The person, firm, or corporation named as such in the Agreement.

1.27 Engineer’s Consultant – A person, firm, or corporation having a contract with Engineer to furnish services as Engineer’s independent professional associate or consultant with respect to the Project and who is identified as such in the Supplementary Conditions.

- 1.28 *Field Order*** – A written order issued by Engineer which orders minor changes in the Work in accordance with paragraph 7.5 but which does not involve a change in the Contract Price or Contract Times.
- 1.29 *Final Acceptance*** – SWACO’s acceptance of the project from the contractor upon certification by the CMT of Contract Completion.
- 1.30 *Final Inspection*** – Final review of the Work of the Contractor by the CMT to determine whether issuance of the certificate of Contract Completion is appropriate.
- 1.31 *Guarantee*** – Legally enforceable assurance, for a period of one year from date of Contract Completion, of quality or performance of the Contractor’s workmanship.
- 1.32 *Laws and/or Regulations*** – Any and all applicable laws, rules, regulations, ordinances, codes, and orders of any and all governmental bodies, agencies, authorities, and courts having jurisdiction.
- 1.33 *Liquidated Damages*** – The sum established in the Contract Documents as the predetermined measure of damages to be paid to SWACO due to the Contractor's failure to complete the Work, or portions thereof, within a stipulated time.
- 1.34 *Liens*** – Liens, charges, security interests, or encumbrances upon real or personal property.
- 1.35 *Material Supplier*** – A person or entity who furnishes materials, supplies or equipment incorporated into the Work of the Project.
- 1.36 *Milestone*** – A principal event specified in the Contract Documents relating to an intermediate completion date or time prior to Substantial Completion of all the Work.
- 1.37 *Notice of Commencement*** – The notice prepared by SWACO identifying the Project, the Contractors, the Surety for each Contractor and the name of SWACO’s designated representative upon whom a Claim Affidavit may be served.
- 1.38 *Notice to Proceed*** – A notice provided by SWACO to the Contractor authorizing the Contractor to proceed with the Work and establishing the date for commencement of the Work.
- 1.39 *Owner*** – The Solid Waste Authority of Central Ohio, and/or including its Board of Trustees, Executive Director, and/or employees. The term “Owner” is interchangeable with the term “SWACO”.
- 1.40 *Partial Occupancy*** – The stage in the progress of the Work when the Project, or a designated portion thereof, is sufficiently complete in accordance with the Contract Documents so that SWACO can occupy or utilize the Project, or designated portion thereof, for its intended use prior to Substantial Completion of all the Work.
- 1.41 *Project*** – The public improvement to be constructed, of which the Work performed under the Contract Documents may be the whole or a part as indicated in the Contract Documents.
- 1.42 *Project Representative*** – The designated representative of SWACO who is assigned to the Project to consult with the Contractor, CMT, and others involved in the Work, and authorized to perform specific responsibilities on behalf of SWACO.
- 1.43 *Project Engineer*** – The individual and/or firm indicated as such in the Contract. The term Engineer shall also be used in the Contract Documents to refer to the Project Engineer.
- 1.44 *Punch List*** – A list of items of Work to be completed or corrected by the Contractor as a condition precedent to Contract Completion and final payment.
- 1.45 *Record Drawings*** – Drawings or computer files revised by an Architect or Engineer to show the changes made during the construction process, based on the As-Built Drawings furnished by the Contractor to SWACO.
- 1.46 *Rendered Harmless*** – The level of exposure is less than any applicable exposure standards set forth in OSHA or other applicable regulations.

1.47 Samples – Physical examples of materials, equipment, or workmanship furnished by Contractor that are representative of some portion of the Work, and establish the standards by which the Work will be judged.

1.48 Schedule of Values – A statement furnished by the Contractor to SWACO and the Project Engineer reflecting the portions of the Contract Price allocated to the various portions of the Work and used as the basis for reviewing the Contractor's Applications for Payment.

1.49 Shop Drawings – Drawings, diagrams, illustrations, schedules, performance charts, brochures, catalog data, and other data or information specially prepared or provided by or for Contractor and submitted by Contractor to illustrate some portion of the Work.

1.50 Site – Lands or areas indicated in the Contract Documents as being furnished by SWACO upon which the work is to be performed, including rights-of-way and easements for access thereto, and such other lands furnished by SWACO which are designated for the use of Contractor.

1.51 Specifications – Those portions of the Contract Documents consisting of the written descriptions and/or technical standards for materials, equipment, construction systems, and workmanship as applied to the Work and certain administrative details applicable thereto.

1.52 Standard – The items named in the Specifications or Addendum to denote kind, quality, or performance requirements for each significant portion of the Work. All Bids or Proposals shall be based on the trade names, catalog numbers, manufacturers, materials or equipment named in the Specifications or Addendum.

1.53 Subcontractor – An individual or firm having a direct contract with Contractor or with any other Subcontractor for the performance of a part of the Work at the Site.

1.54 Substantial Completion – The Work, or a specified part thereof, that has progressed to the point where, in the opinion of the Engineer as evidenced by Engineer's definitive Certificate of Substantial Completion, is sufficiently complete, in accordance with the Contract Documents, so that the Work, or specified part, can be utilized for the purposes for which it is intended; or if no such Certificate is issued, when the Work is complete and ready for final payment as evidenced by Engineer's written recommendation of final payment in accordance with the terms herein. The terms "substantially complete" and "substantially completed" as applied to all or part of the Work refer to Substantial Completion thereof.

1.55 Substitution – A proposed equal to a Standard which must be submitted to SWACO in writing no later than ten (10) Days prior to the Bid opening and which, if approved, will be listed in an Addendum and distributed to all Bidders.

1.56 Supplementary Conditions (Division 1 of the Contract Documents) – Conditions which describe circumstances unique to a particular Project, including without limitation, provisions regarding the assignment of responsibility for refuse removal, and for safety and security precautions and programs regarding temporary Project facilities and utilities, weather and fire protection, scaffolding and equipment, materials and services to be used commonly by Contractors and requiring Contractors to provide assistance in the utilization of any applicable equipment system, preparation of operation and maintenance manuals, necessary training of SWACO personnel for operation and maintenance of the Project.

1.57 Supplier – A manufacturer, fabricator, supplier, distributor, materialman, or vendor having a direct contract with Contractor or with any Subcontractor to furnish materials or equipment to be incorporated in the Work by Contractor or any Subcontractor.

1.58 Surety – A person or entity providing a Bid Guaranty or a Bond to a Bidder or a Contractor to indemnify SWACO against all direct and consequential damages suffered by failure of the Bidder to enter into the Contract or of the Contractor to perform the Contract and to pay all lawful claims of Subcontractors, Material Suppliers and laborers, as applicable.

1.59 SWACO – The Solid Waste Authority of Central Ohio, and/or including its Board of Trustees, Executive Director, and/or employees. The term "SWACO" is interchangeable with the term "Owner."

1.60 *SWACO Caused Delay* – A delay in the Work caused by, or resulting from, the actions of SWACO. Without limitation, a delay in the Work attributable to a Contractor of SWACO or resulting from any weather conditions is not a SWACO Caused Delay.

1.61 *Underground Facilities* – All underground pipelines, conduits, ducts, cables, wires, manholes, vaults, tanks, tunnels, or other such facilities or attachments, and any encasements containing such facilities, including those that convey electricity, gasses, steam, liquid petroleum products, telephone or other communications, cable television, water, wastewater, storm water, other liquids or chemicals, or traffic or other control systems.

1.62 *Unit Price* – The amount stated in the Bid as the price per unit of measurement for materials or services described in the Contract Documents, which cost shall include overhead, profit and any other expense for the Work.

1.63 *Warranty* – Legally enforceable assurance, for the specified duration from acceptance by SWACO, of quality or performance of materials and equipment.

1.64 *Work* – The entire completed construction or the various separately identifiable parts thereof required to be furnished under the Contract Documents. Work includes and is the result of performing or furnishing labor, furnishing and incorporating materials and equipment into the construction, performing or furnishing services, and/or furnishing documents, all as required by the Contract Documents.

1.65 *Work Change Directive* – A written directive to Contractor, issued on or after the Effective Date of the Agreement, signed by SWACO and recommended by Engineer, ordering an addition, deletion, or revision in the Work, or responding to differing or unforeseen physical conditions under which the Work is to be performed. A Work Change Directive will not change the Contract Price or Contract Times, but is evidence that the parties expect that the change directed or documented by a Work Change Directive will be incorporated in a subsequently issued Change Order following negotiations by the parties as to its effect, if any, on the Contract Price or Contract Times as provided herein.

**ARTICLE II
GENERAL PROVISIONS**

2.1 APPLICATION AND GOVERNING LAW

- 2.1.1** The Contractor shall be familiar with all provisions of these General Conditions.
- 2.1.2** There shall be no change in the General Conditions unless so provided in the Supplementary Conditions.
- 2.1.3** The parties to the Contract shall comply with all applicable federal, state and local codes, statutes, ordinances and regulations in the performance of the Work of the Project.
- 2.1.4** SWACO may maintain an action for violations of any law relating to the Project or for any injury to persons or property pertaining to the Work, or for any other cause which is necessary in the performance of SWACO's duties.

2.2 CONDITIONS OF CONTRACT

2.2.1 Nondiscrimination

2.2.1.1 During the performance of the Contract, the Contractor agrees that in the hiring of employees for the performance of the Work, including without limitation Work to be performed by a Subcontractor, no Contractor or Subcontractor, and no person acting on behalf of the Contractor or Subcontractor, shall, by reason of race, religion, creed, national origin, age, sex, disability, Vietnam era Veteran status, or color, discriminate against any citizen in the employment of labor or workers who are qualified and available to perform the Work to which the employment relates.

2.2.1.2 The Contractor further agrees that no Subcontractor, and no person acting on behalf of the Contractor or Subcontractor, shall, in any manner, discriminate against or intimidate any employee hired for the performance of Work on account of race, religion, creed, national origin, age, sex, disability, Vietnam-era Veteran status, or color.

2.2.2 Wages and Hours

2.2.2.1 The Contractor shall pay the prevailing wage rates of the Project locality, as determined by the Ohio Bureau of Employment Services, Wage and Hour Division, for all laborers and mechanics performing Work on the Project.

2.2.2.2 The Contractor shall comply with the provisions, duties, obligations, and is subject to the remedies and penalties of, Ohio Revised Code Chapter 4115, "Wages and Hours on Public Works."

2.2.2.3 SWACO shall, within seven (7) working Days after receipt of a notice of a change in the prevailing wage rates, notify the Contractor of the change. The Contractor shall make the necessary adjustment in the prevailing wage rate and pay any wage increase to its employees during the term of the Contract at no additional cost to SWACO.

2.2.3 Notice of Commencement

2.2.3.1 Pursuant to Ohio Revised Code Section 1311.252, SWACO shall prepare a Notice of Commencement in affidavit form identifying SWACO and setting forth its address; the name, address and Project number of the Project; the name and address of Contractor; the name and address of SWACO's Project manager upon whom a Claim Affidavit may be served; the date of execution of the Contract; and the name and address of the Surety for Contractor.

2.2.3.2 The Notice of Commencement shall be made available to the general public upon request.

2.2.4 Giving Notice

2.2.4.1 Whenever any provision of the Contract Documents requires the giving of any notice, such notice shall be deemed to have been validly given if delivered (a) in person to the individual or to a member of the company or organization for whom the notice is intended, or (b) sent by registered or certified mail, postage prepaid, to the last business address of such individual or company identified herein. The individuals and addresses to which notice should be delivered are those identified in Section 2.2.4.2, below.

2.2.4.2 Any notice to SWACO, the Project Engineer, the Construction Management Team (“CMT”) and/or other Contractors (if any) shall be delivered to the respective address and person designated by each, in the Contract Documents, to receive notice.

2.2.5 Calculation of Time

2.2.5.1 When any period of time is referred to in the Contract Documents by Days, such period of time shall be computed to exclude the first and include the last Day of such period. If the last Day of any such period falls on a Saturday, Sunday or a legal holiday, such Day will be omitted from the computation and such period shall be deemed to end on the next succeeding Day which is not a Saturday, Sunday or legal holiday.

2.2.6 Before Starting Construction

2.2.6.1 Before undertaking each part of the Work, Contractor shall carefully study and compare the Contract Documents, check and verify pertinent figures shown thereon, and all applicable field measurements. Contractor shall promptly report in writing to Engineer any conflict, error, ambiguity, or discrepancy which Contractor may discover and shall obtain a written interpretation or clarification from Engineer before proceeding with any Work affected thereby.

2.2.6.2 Within ten (10) days after the Effective Date of the Agreement, unless otherwise specified, Contractor shall submit to Engineer for review:

2.2.6.2(a) a preliminary progress schedule indicating the times (number of days or dates) for starting and completing the various stages of the Work, including any Milestones as specified in the Contract Documents;

2.2.6.2(b) a preliminary schedule of Shop Drawing and Sample submittals which will list each required submittal and the times for submitting, reviewing, and processing such submittal;

2.2.6.2(c) a preliminary schedule of values for all of the Work which will include quantities and prices of items aggregating the Contract Price and will subdivide the Work into component parts in sufficient detail to serve as the basis for progress payments during construction. Such process will include an appropriate amount of overhead and profit applicable to each item of Work.

2.2.6.3 Preconstruction Conference. Before any Work on site is started, Contractor shall deliver to Owner, with copies to each additional insured identified if applicable, the certificates of insurance (and any other evidence of insurance which may be reasonably requested) Contractor is required to purchase and maintain in accordance with paragraph 3.2.

2.2.6.4 Within twenty (20) days after the Contract time starts to run, but before any Work at the site is started, a conference attended by Contractor, Owner, Engineer, and others as appropriate, will be held to establish a working understanding among the parties as to the Work and to discuss the schedules referred to in paragraphs 2.2.6.2(a) – (c), procedures for handling Shop Drawings and other Submittals, processing Applications for payment, and maintaining required records.

2.2.6.5 Initially Acceptable Schedules. Unless otherwise provided in the Contract Documents, at least ten (10) days before submission of the first Application for Payment a conference attended by Contractor, Owner, Engineer, and others as appropriate, will be held to review for acceptability to

Engineer as provided below the schedules submitted in accordance with paragraph 2.2.6.2. Contractor shall have an additional ten (10) days to make corrections and adjustments and to complete and resubmit the schedules. No progress payments shall be made to Contractor until the schedules are submitted and acceptable to Engineer. The progress schedule will be acceptable to Engineer as providing an orderly progression of the Work to completion within any specified Milestones and the Contract times, but such acceptance will neither impose on Engineer responsibility for the sequencing, scheduling, or progress of the Work nor interfere with or relieve Contractor from Contractor's full responsibility therefor. Contractor's schedule of Shop Drawings and Sample submissions will be acceptable to Engineer as providing a workable arrangement for reviewing and processing the required submittals. Contractor's schedule of values will be acceptable to Engineer as to form and substance.

2.3 CONTRACT DOCUMENTS

2.3.1 Intent

2.3.1.1 The intent of the Contract Documents is to include all items necessary for the proper execution and completion of the Work by the Contractor, and comprise the entire Agreement between Owner and Contractor. The Contract Documents are complementary, and what is required by one shall be as binding as if required by all. The Contractor shall be held to provide all labor and materials necessary for the entire completion of the Work described in the Contract Documents and reasonably implied therefrom to produce the intended results.

2.3.1.2 The Drawings shall generally govern dimensions, details, and locations of the Work. The Specifications shall generally govern quality of materials and workmanship.

2.3.1.3 The organization of the Specifications in divisions, sections, and articles, and the arrangement of Drawings, shall not control the Contractor in dividing the Work among Subcontractors or in establishing the extent of Work to be performed by any trade.

2.3.1.4 Unless otherwise specified in the Contract Documents, when words or phrases which have well-known technical or construction industry or trade meanings are used to describe Work, materials, or equipment, such words or phrases shall be interpreted in accordance with such recognized meanings. Clarifications and interpretations of the Contract Documents shall be issued by Engineer as provided herein.

2.3.1.5 References to standards, specifications, manuals, or codes of any technical society, organization, or association, or to the Laws or Regulations of any governmental authority, whether such reference be specific or by implication, shall mean the latest standard, specification, manual, code, or Laws or Regulations in effect at the time of the Effective Date of the Agreement, except as may otherwise be specifically stated in the Contract Documents.

2.3.1.6 Anything shown on the Drawings and not mentioned in the Specifications or mentioned in the Specifications and not shown on the Drawings shall have the same effect as if shown or mentioned respectively in both.

2.3.2 Reporting and Resolving Inconsistencies

2.3.2.1 If during the performance of the Work, Contractor discovers any conflict, error, ambiguity, or discrepancy within the Contract Documents or between the Contract Documents and any provision of any such Law or Regulation applicable to the performance of the Work or of any such standard, specification, manual, or code, or of any instruction of any Supplier as referred to herein, Contractor shall immediately report said to Engineer in writing and request an interpretation or clarification. Contractor shall not proceed with the Work affected thereby until an amendment, supplement, or clarification to the Contract Documents has been issued. Engineer shall respond in writing within five (5) Days of receipt of the request to any and all requests for interpretation of the Contract Documents.

2.3.2.1(a) Any interpretation or clarification of the Contract Documents made by any person other than the Engineer, or in any manner other than writing, shall not be binding and the Contractor shall not rely upon any such interpretation or clarification.

2.3.2.2 Except as otherwise specified in the Contract Documents, or as may be provided by amendment or supplement thereto, the provisions of the Contract Documents shall take precedence in resolving any conflict, error, ambiguity, or discrepancy between the provisions of the Contract Documents and:

2.3.2.2(a) the provisions of any such standard, specification, manual, code, or instruction (whether or not specifically incorporated by reference in the Contract Documents); or

2.3.2.2(b) the provisions of any such Laws or Regulations applicable to the performance of the Work, unless such an interpretation of the provisions of the Contract Documents would result in violation of such Law or Regulation.

No provision of any such standard, specification, manual, code, or instruction shall be effective to change the duties and responsibilities of Owner, Contractor, Engineer, or any of their subcontractors, consultants, agents, or employees, from those set forth in the Contract Documents, nor shall it be effective to assign to Owner, Engineer, or any agent or consultant thereof, duty or authority to supervise or direct the furnishing or performance of the Work.

2.3.3 Construction Management Team (CMT)

2.3.3.1 The Construction Management Team (CMT), as defined and described herein, shall consist of separate entities (including SWACO's staff), whose specific division of duties shall be defined by SWACO. The CMT shall include SWACO, the Project Representative, the Project Engineer, and the Construction Manager and any of their designated representatives.

2.3.3.2 The Project Representative will function as SWACO's representative to the Contractor during the bidding, construction, commissioning, certification, and warranty phases of this work, and will also serve as the designated representative with respect to the Project during construction and until the issuance of the final Certificate of Payment.

2.3.3.3 All communications as between SWACO and Contractor shall be exclusively through the CMT, with either the Project Representative, Engineer and/or the Construction Manager.

2.3.4 Amending and Supplementing Contract Documents

2.3.4.1 The Contract Documents may be amended to provide for additions, deletions, and/or revisions in the Work or to modify the terms and conditions thereof in one of the following ways:

2.3.4.1(a) a written formal amendment;

2.3.4.1(b) a Change Order, as provided for herein;

2.3.4.1(c) a Work Change Directive, as provided for herein;

2.3.4.2 The requirements of the Contract Documents may be supplemented, and minor variations and deviations in the Work may be authorized, in one or more of the following ways:

2.3.4.2(a) A Field Order, as provided for herein;

2.3.4.2(b) Engineer's approval of a Shop Drawing or Sample;

2.3.4.2(c) Engineer's written interpretation or clarification.

2.3.5 As-Built Drawings

2.3.5.1 Contractor shall keep an accurate record of all approved changes made to the Drawings to show actual installation where installation varies from Work as originally shown, including the exact location and depth of underground utility lines.

2.3.5.2 During the performance of the Work, Contractor shall record any approved changes on the Drawings, neatly in colored pencil, noting new information not shown on the original Drawings.

2.3.5.3 Where Shop Drawings are used, the Contractor shall cross reference the corresponding sheet numbers on the Drawings. Contractor shall note related Change Order numbers where applicable.

2.3.5.4 Contractor shall keep a record of any change made to the Specifications, noting particularly any variation from manufacturer's installation instructions and recommendations.

2.3.5.5 As-Built Drawings should be open to inspection and be located on site.

2.3.6 Availability of Land; Subsurface and Physical Conditions; Reference Points

2.3.6.1 Owner shall furnish, as indicated in the Contract Documents, the lands upon which the Work is to be performed, rights-of-way and easements for access thereto, and any such other land as may be dedicated for use by Contractor. Upon reasonable written request, Owner shall furnish Contractor with a correct statement of recorded legal title and legal description of the land upon which the Work is to be performed. Owner shall identify any encumbrances or restrictions not of general application but specifically related to the use of lands with which Contractor shall comply in performing the Work. Contractor shall provide for any and all additional land and access thereto that may be required for temporary construction facilities or storage of materials and equipment.

2.3.6.2 Subsurface and Physical Conditions. Reference is to be made to the Supplementary Conditions for identification of:

2.3.6.2(a) Subsurface conditions: Those reports of explorations and tests of subsurface conditions at or contiguous to the site utilized by Engineer in preparing the Contract Documents; and

2.3.6.2(b) Physical Conditions: Those drawings of physical conditions in or relating to existing surface or subsurface structures at or contiguous to the site (except Underground Facilities) that have been utilized by Engineer and/or SWACO in preparing the Contract Documents.

2.3.6.3 Contractor may rely upon the general accuracy of the "technical data" contained in such reports and drawings, but such reports and drawings are not Contract Documents. Such "technical data" is identified in the Supplementary Conditions. Except for such reliance on such "technical data", Contractor may not rely upon or make any claim against SWACO, or the CMT with respect to:

2.3.6.3(a) The completeness of such reports and drawings for the Contractor's purposes, including, but not limited to, any aspects of the means, methods, techniques, sequences, and procedures of construction to be employed by Contractor, and safety precautions and programs incident thereto; or

2.3.6.3(b) other data, interpretations, opinions, and information contained in such reports or shown or indicated in such drawings; or

2.3.6.3(c) any Contractor interpretation of or conclusion drawn from any "technical data" or any such other data, interpretations, opinions, or information.

2.3.6.4 Reference Points. SWACO shall provide engineering surveys to establish reference points for construction which in Engineer's judgment are necessary to enable Contractor to proceed with the Work. Contractor shall be responsible for laying out the Work, shall protect and preserve the established reference points, and shall make no changes or relocations without the prior written approval of SWACO. Contractor shall report to Engineer whenever any reference point is lost or destroyed, or requires relocation because of necessary changes in grades or locations, and shall be responsible for the accurate replacement or relocation of such reference points by professionally qualified personnel.

2.3.7 Differing Subsurface or Physical Conditions

2.3.7.1 If Contractor believes that any subsurface or physical condition at or contiguous to the site that is uncovered or revealed either:

2.3.7.1(a) is of such a nature as to establish that any "technical data" on which Contractor is entitled to rely as provided in 2.3.6 above is materially inaccurate; or

2.3.7.1(b) is of such a nature as to require a change in the Contract Documents; or

2.3.7.1(c) differs materially from that shown or indicated in the Contract Documents; or

2.3.7.1(d) is of an unusual nature, and differs materially from conditions ordinarily encountered and generally recognized as inherent in Work of the character provided for in the Contract Documents; then Contractor shall, within twenty-four (24) hours after becoming aware thereof and before further disturbing the subsurface or physical conditions affected thereby or performing any Work in connection therewith, notify Engineer in writing about such condition. Contractor shall not further disturb such conditions or perform any Work in connection therewith, until receipt of a written ORDER TO DO SO.

2.3.7.2 Within forty-eight (48) hours after receipt of the written notice as provided above, Engineer shall review the pertinent condition, determine the necessity of SWACO obtaining additional exploration or tests with respect thereto, and advise SWACO and Contractor in writing of Engineer's findings and conclusions.

2.3.7.3 If Engineer concludes that a change in the Contract Documents is required as a result of a condition that meets one or more of the categories in paragraph 2.3.7.1, a Work Change Directive or Change Order will be issued as required herein to reflect and document the consequences of such change.

2.3.7.4 Possible Price and Time Adjustments. An equitable adjustment in the Contract Price or Times, or both, will be allowed to the extent that the existence of such uncovered or revealed condition causes an increase or decrease in Contractor's cost of, or time required for performance of, the Work, subject to the following:

2.3.7.4(a) Such condition must meet any one or more of the categories described in paragraphs 2.3.7.1(a) through 2.3.7.1(d), inclusive;

2.3.7.4(b) a change in the Contract Documents pursuant to paragraph 2.3.7.3 will not be an automatic authorization of nor a condition precedent to entitlement to any such adjustment;

2.3.7.4(c) with respect to Work that is paid for on a Unit Price basis, any adjustment in Contract Price will be subject to the provisions relating to Unit Price Work; and

2.3.7.4(d) Contractor shall not be entitled to any adjustment in the Contract Price or Times if:

(i) Contractor knew of the existence of such conditions at the time Contractor made a final commitment to SWACO relating to Contract Price and Times by the submission of a bid or becoming bound under a negotiated contract; or

(ii) the existence of such conditions could reasonably have been discovered or revealed as a result of any examination, investigation, exploration, test, or study of the site and contiguous areas as required by the Bidding Requirements or Contract Documents to be conducted by or for Contractor prior to Contractor making such a final commitment; or

(iii) Contractor failed to give the written notice within the time as required by paragraph 2.3.7.1.

If SWACO and Contractor are unable to agree on entitlement to or as to the amount or length of any such equitable adjustment in the Contract Price or Contract Times, a claim may be made under the provisions relating to the Cost of the Work. However, SWACO, Engineer and/or Engineer's

Consultants shall not be liable to Contractor for any claims, costs, losses, or damages sustained by Contractor on or in connection with any other project or anticipated project.

2.3.8. Physical Conditions – Underground Facilities

2.3.8.1 Shown or Indicated. The information or data shown or indicated in the Contract Documents with respect to existing Underground Facilities at or contiguous to the site is based on information and data furnished to SWACO or Engineer by the owners of such underground Facilities or by others. Unless it is otherwise expressly provided in the Supplementary Conditions:

2.3.8.1(a) SWACO and Engineer shall not be responsible for the accuracy or completeness of any such information or data; and

2.3.8.1(b) The cost of all of the following will be included in the Contract Price and Contractor shall have full responsibility for:

- (i) reviewing and checking all such information and data,
- (ii) locating all Underground Facilities shown or indicated in the Contract Documents,
- (iii) coordination of the Work with the owners of such Underground Facilities during construction, and
- (iv) the safety and protection of all such Underground Facilities as provided herein and repairing any damage thereto resulting from the Work.

2.3.8.2 Not Shown or Indicated. If an Underground Facility is uncovered or revealed at or contiguous to the site which was not shown or indicated in the Contract Documents, Contractor shall, within twenty-four (24) hours after becoming aware thereof and before further disturbing conditions affected thereby or performing any Work in connection therewith (except in an emergency as provided for herein), identify the owner of such Underground Facility and give written notice to that owner and to SWACO and Engineer. Engineer will promptly review the Underground Facility and determine the extent, if any, to which a change is required in the Contract Documents to reflect and document the consequences of the existence of the Underground Facility. If Engineer concludes that a change in the Contract Documents is necessary, a Work Change Directive or Change Order will be issued as provided for in Article VIII to reflect and document such consequences. During such time, Contractor shall be responsible for the safety and protection of such Underground Facility. Contractor shall be allowed an increase in Contract Price or an extension of the Contract Time, or both, to the extent they are attributable to the existence of any Underground Facility that was not shown or indicated in the Contract Documents and that Contractor did not know if and could not have reasonably been expected to be aware of or have anticipated. If SWACO and Contractor are unable to agree on entitlement to or the amount or length of any such adjustment in Contract Price or Contract Times, Contractor may make a claim therefor as provided herein. However, SWACO, Engineer and/or Engineer's Consultants shall not be liable to Contractor for any claims, costs, losses, or damages sustained by Contractor on or in connection with any other project or anticipated project.

ARTICLE III BONDS AND INSURANCE

3.1 PERFORMANCE, PAYMENT, AND OTHER BONDS

3.1.1 Contractor shall furnish Performance and Payment Bonds, each in an amount at least equal to the Contract Price, as security for the faithful performance and payment of all Contractor's obligations under the Contract Documents. These Bonds shall remain in effect at least until one (1) year after the date when the final payment becomes due, except as provided otherwise by the applicable Laws or Regulations or the Contract Documents. Contractor shall also furnish such other Bonds as are required by the Supplementary Conditions. All Bonds shall be in the form prescribed by the Contract Documents, and shall be executed by such sureties as are named in the current list of "Companies

Holding Certificates of Authority as Acceptable Sureties on Federal Bonds and as Acceptable Reinsuring Companies” as published in Circular 570 (amended) by the Audit Staff, Bureau of Government Financial Operations, U.S. Treasury Department. All Bonds signed by an agent must be accompanied by a certified copy of such agent’s authority to act.

3.1.1(a) If the surety on any Bond furnished by Contractor is declared bankrupt, becomes insolvent, or its right to do business is terminated in any state where any part of the Project is located, or it ceases to meet the requirements of paragraph 3.1.1, Contractor shall within ten (10) days thereafter substitute another Bond and surety, both of which must be acceptable to SWACO.

3.1.2 All bonds and insurance required by the Contract Documents to be purchased and maintained by Contractor shall be obtained from surety or insurance companies duly licensed or authorized to issue Bonds or insurance policies in the jurisdiction in which the Project is located for the limits and coverages so required. Such surety and insurance companies shall also meet such additional requirements and qualifications as may be provided in the Supplementary Conditions.

3.1.3 Contractor shall deliver to SWACO, with copies to each additional insured as identified in the Supplementary Conditions, if applicable, certificates of insurance and other evidence of insurance as requested by SWACO, which Contractor is required to purchase and maintain in accordance with paragraph 3.2 below.

3.1.4 Bond Reduction

3.1.4(a) Pursuant to Ohio Revised Code Section 153.80, and upon notice and consent of the Contractor’s Surety, SWACO, in its sole discretion, may reduce the Bond by up to twenty-five percent (25%) of the total amount of the Bond after at least fifty percent (50%) of the Work has been completed, and by up to fifty percent (50%) after at least seventy-five percent (75%) of the Work has been completed, provided that all of the following conditions are met:

(i) SWACO determines that the percentage of Work that has been completed at the time of determination has been satisfactorily performed and meets the terms of the Contract Documents, including all provisions regarding the time when the entire Project, or any specified portion of the Work, must be completed;

(ii) SWACO determines that no disputed claim caused by Contractor exists or remains unresolved;

(iii) The Bid upon which the Contract is based was not more than ten percent (10%) below the next lowest Bid or not more than ten percent (10%) below the cost estimate for the Work as published in the Notice to Bidders.

3.2 CONTRACTOR’S LIABILITY INSURANCE

Contractor shall purchase and maintain the following liability and other insurance at the indicated limits and under the terms set forth below:

3.2.1 General Liability Insurance, containing the following limits and terms:

3.2.1(a) \$1,000,000.00 per occurrence

3.2.1(b) \$2,000,000.00 aggregate

3.2.1(c) \$1,000,000.00 Products/Completed Operations Aggregate

3.2.1(d) Name SWACO as an additional insured

3.2.1(e) Waiver of subrogation in favor of SWACO and all related entities or subsidiaries, employees, agents and/or representatives

3.2.2 *Automobile Liability Insurance*, containing a limit of \$1,000,000.00 per occurrence.

3.2.3 *Worker’s Compensation and Employer’s Liability Insurance*, containing the following limits:

3.2.3(a) Statutory Limits for the State of Ohio

3.2.3(b) \$500,000.00/\$500,000.00/\$500,000.00 Employer’s Liability Limit

3.2.4 *Professional Liability or Professional Errors and Omissions Insurance* with the following limits:

- 3.2.4(a)** \$5,000,000.00 per claim
- 3.2.4(b)** \$5,000,000.00 aggregate

3.2.5 *Umbrella Liability Insurance* containing the following limits and terms:

- 3.2.5(a)** \$4,000,000.00 per occurrence
- 3.2.5(b)** Following Form Coverage as provided below

3.3 BUILDER'S RISK - NEW CONSTRUCTION

3.3.1 Unless otherwise specified in the Contract Documents, Contractor shall provide and maintain, during the progress of the Work and until the execution of the certificate of Contract Completion by SWACO, a builder's risk insurance policy to cover all Work in the course of construction including false-work, temporary buildings, and structures and materials used in the construction process, stored on or off site, or while in transit. Such insurance shall be on a "Risk of Direct Physical Loss" form policy and shall insure against the perils of fire and extended coverage and physical loss or damage including, without limitation, theft, vandalism, malicious mischief, earthquake, tornado, lightning, explosion, breakage of glass, flood, collapse, and water damage. It shall also include debris removal, demolition occasioned by enforcement of any applicable legal requirement, and shall cover reasonable compensation for SWACO's services and expenses required to limit further loss.

3.3.1(a) Coverage must include provision to pay the reasonable extra costs of expediting temporary and/or permanent repairs to, or permanent replacement of, damaged property. This shall include overtime wages and the extra cost of "express" or other means for rapidly transporting materials and supplies necessary to such repair or replacement.

3.3.1(b) Such builder's risk policy shall protect the Contractor, SWACO, and the CMT from loss and provide coverage for materials in transit or stored off site and identified for the Project.

3.3.1(c) Coverage for other perils may be required if specified in the Supplemental Conditions.

3.3.2 Unless otherwise specified in the Contract Documents, the builder's risk policy shall be written in an amount equal to 100 percent (100%) of the Contract Price, including landscaping, paving, and other Project Work.

3.3.3 The Builder's Risk policy shall specifically permit and allow for partial occupancy by SWACO prior to acceptance of the Project by SWACO.

3.4 INSURANCE POLICY REQUIREMENTS

3.4.1 Each policy of insurance required to be purchased and maintained by the Contractor shall:

3.4.1(a) Be purchased from an insurance carrier rated by A.M. Best as A-, VII or better

3.4.1(b) Each policy and respective certificate of insurance shall expressly provide that should Contractor's insurance lapse, be cancelled, non-renewed or materially altered, Contractor shall provide SWACO with no less than thirty (30) days prior written notice of such cancellation, non-renewal, expiration or material alteration of the coverage contained in such policy or evidenced by such certificate of insurance.

3.4.1(c) Within fifteen (15) days of the execution of this Contract by SWACO's Executive Director or his designee, Contractor shall without demand furnish SWACO with a certified copy of any insurance certificate and/or additional insured endorsement required to be purchased or maintained by Contractor under the terms of this Contract. Failure of Contractor to comply with the terms and conditions of this paragraph shall constitute a material breach of this Contract and shall be cause for termination of this Contract by SWACO.

3.4.2 Contractor shall maintain all insurance in the required amounts, without interruption, from the date of the execution of this Contract until the date of the termination of this Contract or the date of

payment of the final invoice issued by Contractor, whichever is later. Failure of Contractor to comply with the terms and conditions of this paragraph shall constitute a material breach of this Contract and shall be cause for termination of this Contract by SWACO.

3.4.3 Insurance policies required to be purchased and maintained by Contractor may include a reasonable loss deductible, as is customary for Contractor's industry, which shall be the sole responsibility of Contractor to pay in the event of any covered loss.

3.4.4 SWACO and Contractor waive all rights against each other for damages caused by fire or other perils to the extent of actual recovery of any insurance proceeds under any property insurance obtained pursuant to the requirements set forth above or any other property insurance applicable to the performance of the Services, except such rights as they have to proceeds of such insurance held by SWACO as fiduciary. Contractor agrees to obtain waivers in favor of SWACO of such claims by all of its Subcontractors.

3.4.5 Notwithstanding paragraph 3.4.4 above, and regardless of the amount of any insurance proceeds recovered by the parties under the insurance policies set forth above, Contractor shall be liable to SWACO for the full amount of any claims, damages, losses, liens, causes of action, suits, judgments and expenses (including reasonable attorney's fees and other reasonable costs of defense) of any nature, kind or description which are in excess of such insurance proceeds.

3.4.6 Correction, Repair or Replacement of Insured Losses. Contractor shall promptly correct, repair and/or replace any items, work, and/or materials installed as part of the Services and damaged and/or destroyed as a result of an insured loss or damage. Such correction, repair and/or replacement shall be Contractor's sole responsibility and shall be undertaken and completed at no additional cost to SWACO.

ARTICLE IV CONTRACTOR'S RESPONSIBILITIES

4.1 CONSTRUCTION SUPERVISION

4.1.1 Contractor shall supervise, inspect, and direct the Work competently and efficiently, devoting such attention thereto and applying such skills and expertise as may be necessary to perform the Work in accordance with the Contract Documents. Contractor shall be solely responsible for, and have control over, all construction means, methods, techniques, sequences, and procedures of construction and for all portions of the Contractor's Work. Contractor shall not be responsible for the negligence of others in the design or specification of a specific means, method, technique, sequence, or procedure of construction which is shown or indicated and expressly required by the Contract Documents, but Contractor shall be responsible for any injury or damage which may result from improper construction, installation, maintenance, or operation of Contractor's Work to the fullest extent permitted by law.

4.1.1(a) Contractor shall provide continuous supervision at the Project site by a competent superintendent(s) when any Work is being performed, unless such requirement is waived by SWACO in writing.

4.1.1(b) Contractor's superintendent shall have responsibility and authority to act on behalf of the Contractor. All communications and notices to the Contractor's superintendent shall be as binding as if given directly to the Contractor.

4.1.1(c) Contractor shall submit an outline of the qualifications and experience of Contractor's proposed superintendent, including references, to SWACO within ten (10) Days of issuance of the Notice to Proceed or within five (5) Days of the designation of a replacement superintendent for any reason.

(i) SWACO reserves the right to reject Contractor's proposed superintendent. Failure of SWACO to notify Contractor of such rejection within ten (10) Days of receipt of the required information shall indicate that SWACO has no such objection.

(ii) If SWACO rejects Contractor's superintendent, Contractor shall provide a replacement superintendent at no additional cost to SWACO.

4.1.1(d) Contractor shall not replace the Contractor's designated superintendent without the written approval of SWACO. If Contractor proposes to change its superintendent, Contractor shall submit to SWACO written justification for the replacement, along with the outline required pursuant to paragraph 4.1.1(c) above.

4.1.2 Contractor shall provide competent, suitably qualified personnel to survey, lay out, and construct the Work as required by the Contract Documents. Contractor shall at all times maintain good discipline and order at the Site. Except as otherwise required for the safety or protection of persons, the Work, or property at the Site or adjacent thereto, and except as otherwise indicated in the Contract Documents, all Work at the Site shall be performed during regular working hours and Contractor shall not permit overtime or the performance of Work on Saturday, Sunday, or any legal holiday without SWACO's written consent given after prior written notice to Engineer.

4.1.3 Unless otherwise specified in the Contract Documents, Contractor shall furnish and assume full responsibility for all materials, equipment, labor, transportation, construction equipment and machinery, tools, appliances, fuel, power, lighting, heat, telephone, water, sanitary facilities, temporary facilities, and all other facilities and incidentals necessary for the furnishing, performance, testing, start-up, and completion of the Work.

4.1.4 All materials and equipment shall be of good quality and new, except as otherwise provided in the Contract Documents. All warranties and guarantees specifically called for by the Specifications shall expressly run to the benefit of SWACO. If required by Engineer, Contractor shall furnish satisfactory evidence, including reports of required tests, as to the kind and quality of materials and equipment. All materials and equipment shall be applied, installed, connected, erected, used, cleaned, and conditioned in accordance with the instructions of the applicable Supplier, except as otherwise provided in the Contract Documents.

4.1.4(a) Contractor shall be responsible for the proper storage of all material and equipment brought to the Project.

4.1.4(b) After material or equipment is no longer required for the Work, Contractor shall remove such material and equipment from the Project.

4.1.4(C) ONLY MATERIALS AND EQUIPMENT WHICH ARE TO BE USED DIRECTLY IN THE WORK OR ARE REQUIRED TO PERFORM THE WORK (I.E. FORMS, SCAFFOLDING, ETC.) SHALL BE BROUGHT TO OR STORED AT THE PROJECT BY CONTRACTOR, CONTRACTOR'S SUBCONTRACTORS, AND CONTRACTOR'S SUPPLIERS.

4.1.5 Contractor shall take field measurements, verify field conditions, and carefully compare such field measurements, conditions, and other information known to Contractor with the Contract Documents before commencing activities. Errors, inconsistencies, or omissions discovered shall be reported to the Engineer immediately.

4.1.5(a) Unless otherwise specified in the Contract Documents, Contractor shall be responsible for properly and accurately laying out all lines, levels, elevations, and measurements for all of Contractor's Work as required by the Contract Documents.

4.2 PROGRESS SCHEDULE

4.2.1 Contractor shall adhere to the Progress Schedule established in accordance with paragraph 2.2.6.5 as it may be adjusted from time to time as provided below:

4.2.1(a) Contractor shall submit to Engineer for acceptance, to the extent indicated in paragraphs 2.2.6.2 through 2.2.6.5, proposed adjustments in the Progress Schedule that will not change the Contract Times or Milestones. Such adjustments will conform generally to the progress schedule then in effect and additionally will comply with any provisions of the General Requirements applicable thereto.

4.2.1(b) Proposed adjustments in the Progress Schedule that will change the Contract Times or Milestones shall be submitted in accordance with the requirements herein relating to Change of Contract Times. Such adjustments may only be made by a Change Order or Written Amendment in accordance with said provisions.

4.2.2 Contractor shall allow sufficient time for installation, inspection, or testing of any Work by Engineer and/or the CMT before covering or closing any applicable portion of the Project.

4.2.3 CONTRACTOR SHALL NOT CUT AWAY ANY TIMBER OR DIG UNDER ANY FOUNDATION OR INTO ANY WALL, OR OTHER PART OF THE PROJECT, WITHOUT NOTIFYING ENGINEER IN WRITING.

4.2.4 Contractor shall install the Work in accordance with the Contract Documents and any installation recommendations of the manufacturer, including required dryness for installation of the various materials.

4.2.5 CONTRACTOR SHALL COMPLY WITH ALL REQUIREMENTS AND CONDITIONS OF THE NATIONAL POLLUTANT DISCHARGE ELIMINATION SYSTEM (NPDES) GENERAL PERMIT, INCLUDING, BUT NOT LIMITED TO, IMPLEMENTING AND MAINTAINING THE CONTROL MEASURES SPECIFIED IN THE STORM WATER POLLUTION PREVENTION PLAN, MAINTAINING RECORDS OF CONSTRUCTION ACTIVITIES, REMOVING MATERIALS NO LONGER REQUIRED, AND TAKING PROPER ACTION IF THERE IS A REPORTABLE QUANTITY SPILL.

4.3 SUBSTITUTES AND “OR EQUAL” ITEMS

4.3.1 Whenever an item of material or equipment is specified or described in the Contract Documents by using the name of a proprietary item or the name of a particular Supplier, the specification or description is intended to establish the type, function, and quality required. Unless the specification or description contains or is followed by words to the effect that no like, equivalent, “or-equal” item or that no substitution is permitted, other items of materials or equipment, or materials or equipment of other Suppliers, may be accepted by Engineer under the following circumstances:

4.3.1(a) “Or-Equal.” If in Engineer’s sole discretion an item of material or equipment proposed by Contractor is functionally equal to that named and sufficiently similar so that no change in related Work will be required, it may be considered by Engineer as an “or-equal” item, in which case review and approval of the proposed item may, in Engineer’s sole discretion, be accomplished without compliance with some or all of the requirements for acceptance of proposed substitute items.

4.3.1(b) Substitute Items. If in Engineer’s sole discretion an item of material or equipment proposed by Contractor does not qualify as an “or-equal” item under 4.3.1(a), it will be considered a proposed Substitute item. Contractor shall submit sufficient information as provided below to allow Engineer to determine that the item of material or equipment proposed is essentially equivalent to that named and an acceptable substitute therefor. The procedure for review by Engineer shall include the following as supplemented as Engineer may decide is appropriate under the circumstances:

(i) Requests for review of proposed Substitute items of material or equipment will not be accepted by Engineer from anyone other than Contractor. If Contractor wishes to furnish or use a substitute item of material or equipment, Contractor shall first make written application to Engineer for acceptance thereof, certifying that the proposed Substitute will

adequately perform the functions and achieve the results called for by the general design, be similar in substance to that specified, and be suited to the same use as that specified.

(ii) The application shall state the extent, if any, to which the evaluation and acceptance of the proposed Substitute will prejudice Contractor's achievement of Substantial Completion on time, whether acceptance of the Substitute for use in the Work will require a change in any of the Contract Documents, or in the provisions of any other direct contract with SWACO for work on the Project, to adapt the design to the proposed Substitute, and whether incorporation or use of the Substitute in connection with the Work is subject to payment of any license fee or royalty. All variations of the proposed Substitute from that specified will be identified in the application and available maintenance, repair, and replacement service will be indicated.

(iii) The application will also contain an itemized estimate of all costs or credits that will result directly or indirectly from acceptance of such Substitute, including costs of redesign and claims of other contractors affected by the resulting change, all of which will be considered by Engineer in evaluating the proposed substitute. Engineer may require Contractor to furnish additional data about the proposed Substitute.

All data to be provided by Contractor in support of any proposed "or-equal" or Substitute items will be at Contractor's expense.

4.3.2 Substitute Construction Methods or Procedures. If a specific means, method, technique, sequence, or procedure of construction is shown or indicated in and expressly required by the Contract Documents, Contractor may furnish or utilize a substitute means, method, technique, sequence, or procedure of construction acceptable to Engineer. Contractor shall submit sufficient information to allow Engineer, in Engineer's sole discretion, to determine that the substitute proposed is equivalent to that expressly called for by the Contract Documents. The procedure for review by Engineer will be similar to that provided for in paragraph 4.3.1(b). Notwithstanding any determination by Engineer under this paragraph, Contractor shall remain solely responsible for all means, methods, techniques, sequences or procedures of construction and shall be responsible for any claims, damages, losses, or schedule impacts that may result from the same.

4.3.3 Engineer's Evaluation. Engineer will be allowed a reasonable time within which to evaluate each proposal or submittal made pursuant to paragraphs 4.3.1(b) and 4.3.2. Engineer will be the sole judge of acceptability, and no "or-equal" or Substitute will be ordered, installed, or utilized without Engineer's prior written acceptance which will be evidenced by either a Change Order or an approved Shop Drawing. SWACO may require Contractor to furnish, at Contractor's expense, a special performance guarantee or other surety with respect to any "or-equal" or Substitute. Engineer will record the time required by Engineer and/or Engineer's consultants in evaluating Substitutes proposed or submitted by Contractor pursuant to paragraphs 4.3.1(b) and 4.3.2, and in making changes to the Contract Documents, or in the provisions of any other direct contract with SWACO for work on the Project, occasioned thereby. Regardless of Engineer's acceptance of a Substitute item so proposed or submitted by Contractor, Contractor shall reimburse SWACO for the charges of Engineer and/or Engineer's consultants for evaluating each such proposed Substitute item.

4.4 PROTECTION OF THE PROJECT

4.4.1 Contractor shall protect the Work from weather, and shall maintain the Work and all materials, apparatus, and fixtures free from injury or damage during the entire construction period.

4.4.1(a) Work likely to be damaged shall be covered or protected at all times to prevent damage.

4.4.1(b) Any Work damaged by failure of Contractor to provide coverage or protection shall be removed and replaced with new Work at Contractor's expense.

4.4.1(c) Any adjacent property, including, without limitation, facilities, roads, walks, shrubbery, plants, trees, or turf, damaged during and/or as a result of the Contractor's performance of the Work shall be promptly repaired or replaced at Contractor's expense.

4.4.2 Contractor shall protect the Project and existing or adjacent property from damage at all times and shall erect and maintain necessary barriers, furnish and keep lighted necessary danger signals at night, and take precautions to prevent injury or damage to persons or property.

4.4.3 Contractor shall not load, nor permit any part of the Project to be loaded, in any manner that will endanger the Project, or any portion thereof, nor shall the Contractor subject any part of the Project or existing or adjacent property to stress or pressure that will endanger the property.

4.4.4 Contractor shall provide all temporary bracing, shoring, and other structural support required for the safety of the Project and proper execution of the Work.

4.5 MATERIAL, EQUIPMENT, AND CLEAN UP OF THE PROJECT

4.5.1 Use of the Premises. Contractor shall confine construction equipment, the storage of materials and equipment, and the operations of workers to the Site and land areas identified in and permitted by the Contract Documents and other land and areas as permitted by any applicable Laws and Regulations, rights-of-way, permits, and easements, and shall not unreasonably encumber the premises with construction equipment or other materials or equipment. Contractor shall assume full responsibility for any damage to any such land or area, or to the owner or occupant thereof or of any adjacent land or areas, resulting from the performance of the Work. Should any claim be made by any such owner or occupant because of the performance of the Work, Contractor shall have the responsibility to promptly settle or resolve the claim with the other such party.

4.5.2. Contractor's materials and equipment shall not cause damage to the Project or adjacent property and shall not endanger any person at, or in the vicinity of, the Project.

4.5.2(a) Each of the equipment items and materials necessary for the construction as set forth in paragraph 4.1.4 above shall be in good working order, be properly maintained, and free from leaks and/or dripping fuel, oil, anti-freeze, hydraulic fluid, or other fluids onto or about the Project. Any leakage of fuel, oil, anti-freeze, hydraulic fluid, and/or other fluids shall be immediately cleaned by Contractor and the cause of such leak immediately repaired.

4.5.2(b) Contractor shall be responsible for the proper storage of all materials, paints, solvents, cleaners, hardeners and/or other such items on or about the Project. Any spills of such items shall be immediately cleaned up by Contractor.

4.5.2(c) If Contractor fails to follow the provisions and/or conditions set forth in paragraphs 4.5.2(a) and 4.5.2(b) of these General Conditions, SWACO may, at its option, clean up and remove any spills and/or debris on or about the Project and deduct the costs thereof from any payments owed to Contractor then or thereafter coming due.

4.5.3 Any injury to a person or persons or damage to property resulting from Contractor's material or equipment shall be the responsibility of Contractor. This provision is intended to be, and shall be construed as, consistent with, and not in conflict with, Ohio Revised Code Section 4113.62.

4.5.4 Clean Up. During the progress of the Work, Contractor shall keep the premises free from accumulation of waste materials, rubbish, and other debris resulting from the Work. At the completion of the Work, Contractor shall remove all waste materials, rubbish, and debris from and about the premises as well as all tools, appliances, construction equipment, machinery, and surplus materials. Contractor shall leave the Site clean and ready for occupancy by SWACO at the Substantial Completion of the Work. Contractor shall restore to original condition all property not designated for alteration by the Contract Documents.

4.5.4(a) If Contractor fails to maintain the areas adjacent to the Project and the Project site clean and free of waste materials and rubbish, SWACO shall direct the local jurisdiction having

responsibility for the area to clean the area. The cost of cleaning the area adjacent to the Project shall be deducted from any monies due the Contractor in an amount SWACO determines to be just. The decision of SWACO shall be final.

4.6 LABOR

4.6.1 Contractor shall be solely responsible for scheduling and coordinating the Work of Subcontractors, Suppliers, and other persons or organizations performing or furnishing any of the Work under a direct or indirect contract with Contractor. Contractor shall require all Subcontractors, Suppliers, and other persons or organizations performing or furnishing any of the Work to communicate with Engineer directly through Contractor.

4.6.2 Contractor shall maintain a sufficient workforce to efficiently execute the Work in accordance with the Construction Schedule.

4.6.3 Contractor shall enforce good discipline and order among Contractor's employees, Contractor's Subcontractor's employees, and Contractor's Suppliers. Contractor shall not permit employment of unfit persons or persons not skilled in the tasks assigned to them.

4.6.4 SWACO may, upon written notice, require Contractor to dismiss from the Project any person employed by Contractor, Contractor's Subcontractors and/or Contractor's Suppliers, who is found by SWACO, pursuant to a recommendation from Engineer and/or the CMT, to be incompetent, guilty of misconduct, careless, or detrimental to the construction or the Work of the Project.

4.6.4(a) Contractor shall not employ any Subcontractor, Supplier, or other person or organization, whether initially or as a substitute, against whom SWACO, in its sole discretion, may have reasonable objection.

4.6.5 If the Supplementary Conditions require the identity of certain Subcontractors, Suppliers, or other persons or organizations, including those who are to furnish the principal items of material or equipment, to be submitted to SWACO in advance of the specified date, and/or prior to the Effective Date of the Agreement, for acceptance by SWACO and/or Engineer, and if Contractor has submitted a list thereof in accordance with the Supplementary Conditions, acceptance by SWACO or Engineer, either in writing or by failure to make a written objection thereto by the date indicated for acceptance or objection in the bidding documents or the Contract Documents, of any such Subcontractor, Supplier, or other person or organization so identified may be revoked on the basis of reasonable objection after due investigation, in which case Contractor shall submit an acceptable substitute, the Contract Price will be adjusted by the difference in the cost occasioned by such substitution and an appropriate Change Order will be issued or written amendment signed. No acceptance by SWACO or Engineer of any such Subcontractor, Supplier, or other person or organization shall constitute a waiver of any right of SWACO or Engineer to reject defective Work.

4.6.6 Contractor shall employ all legal efforts to minimize the likelihood or effect of any strike, Work stoppage, or other labor disturbance. Informational pickets shall not justify any Work stoppage.

4.6.7 Contractor shall be fully responsible to SWACO and Engineer for all acts and omissions of the Subcontractors, Suppliers, and other persons and organizations performing or furnishing any of the Work under a direct or indirect contract with Contractor, just as Contractor is responsible for Contractor's own acts and omissions. Nothing in the Contract Documents shall create for the benefit of any such Subcontractor, Supplier, or other person or organization any contractual relationship between SWACO any such Subcontractor, Supplier, or other person or organization, nor shall it create any obligation on the part of SWACO to pay any monies due any such Subcontractor, Supplier, or other person or organization except as otherwise may be required.

4.6.8 The divisions and sections of the Specifications and the identifications of any Drawings shall not control Contractor in dividing the Work among Subcontractors or Suppliers or delineating the Work to be performed by any specific trade.

4.6.9. All Work performed for Contractor by a Subcontractor or Supplier will be pursuant to an appropriate agreement between Contractor and the Subcontractor or Supplier which specifically binds said parties to the applicable terms and conditions of the Contract Documents for the benefit of SWACO.

4.6.10 Local and State Permits. Unless otherwise specified in the Contract Documents or Supplementary Conditions, and except as provided in paragraph 4.6.10(a), Contractor shall obtain, maintain, and pay for any permit or license required by local and state authorities having jurisdiction over the Project, including, but not limited to any required demolition permit. SWACO shall assist Contractor, when necessary, in obtaining such permits and licenses. Contractor shall pay all governmental charges and inspection fees necessary for the prosecution of the Work, which are applicable at the time of the opening of the Bids, or if there are no Bids, on the Effective Date of the Agreement. Contractor shall pay all charges of utility owners for connections to the Work, and SWACO shall pay all charges of such utility owners for capital costs related thereto.

4.6.10(a) Building Permits. SWACO shall secure required general building permits, and any required "permit to install."

4.6.10(b) Contractor shall schedule the intermediate and final inspections required for any permit certification. Contractor shall give Engineer and/or the CMT reasonable notice of the date arranged for any inspection.

4.7 COMPLIANCE WITH LAWS AND REGULATIONS

4.7.1 Contractor shall give all notices and comply with all Laws and Regulations, including all applicable federal, State, and local laws, as well as Environmental Laws, rules, permits, ordinances, and regulations relating to or regulating the construction, operation, and/or performance of the Work for the Project. Except when required, SWACO shall not be responsible for monitoring Contractor's compliance with said Laws or Regulations.

4.7.2 If Contractor performs any Work knowing or having reason to know that said is contrary to any Laws or Regulations, Contractor shall bear all claims, costs, losses, and damages caused by, arising out of, or resulting therefrom.

4.7.3 Contractor shall pay all sales, consumer, use, and other similar taxes required to be paid by Contractor in accordance with the Laws and Regulations of the locale of the Project which are applicable during the performance of the Work.

4.8 SAFETY AND PROTECTION

4.8.1 Contractor shall be fully and solely responsible for initiating, maintaining, and supervising all safety precautions and programs in connection with the Work. Contractor shall take all necessary precautions for the safety of, and shall provide the necessary protections to prevent damage, injury, or loss to:

4.8.1(a) All persons on the Work site or who may be affected by the Work;

4.8.1(b) All the Work, materials, and equipment to be incorporated therein, whether in storage on or off the site; and

4.8.1(c) Other property at the site or adjacent thereto, including trees, shrubs, lawns, walks, pavements, roadways, structures, utilities, and Underground Facilities not designated for removal, relocation, or replacement in the course of the construction.

Contractor shall comply with all applicable provisions of Federal, State, and municipal safety laws and buildings codes.

4.8.2 Contractor shall comply with the rules and regulations of the Department of Labor and the Occupational Safety and Health Act (OSHA) and shall be solely responsible for any fine or cost incurred as a result of any violation or alleged violation rules and/or regulations.

4.8.3 Prior to starting the Work, Contractor shall inform and/or provide all of Contractor's Subcontractors with the methods and equipment for protecting the Project and persons from fire damage in accordance with applicable federal, State and local fire regulations.

4.8.4 Methods and equipment for protecting persons and the Project shall be subject to the inspection and approval of the appropriate governmental authority having jurisdiction over the Project site.

4.8.5 Contractor shall remove all snow and ice as may be required for access to the Project.

4.8.6 Contractor shall not permit or allow any person, including any person licensed to carry a concealed handgun by this state or any other state, to possess, have under his or her control, convey, attempt to convey, or bring a handgun or any other firearm, whether openly or concealed, into any building or structure located on or about the site or the Work Area. This restriction shall not apply to any law enforcement person who is currently acting within his or her scope of duties or any governmental employee who is authorized to carry a firearm as part of his or her scope of duties and who is currently acting pursuant to said duties. Further, the Contractor shall not permit or allow any person to possess, have under his or her control, convey, attempt to convey, or bring a handgun or any other firearm, whether openly or concealed, into, onto or about the grounds of the Site or the Work Area. This restriction shall not apply to any law enforcement person who is currently acting within his or her scope of duties or any governmental employee who is authorized to carry a firearm as part of his or her scope of duties and who is currently acting pursuant to his or her scope of duties; or to any person who has a valid license issued by this state or a state which has entered into an appropriate agreement with the Attorney General of the State of Ohio to carry a concealed handgun, and who is carrying a handgun onto the grounds of these premises.

4.8.7 Contractor shall delineate smoking areas on the Project site and limit smoking and related activities to those areas. Contractor shall submit location of these areas for approval by Engineer.

4.8.8 Contractor shall comply with all applicable Laws and Regulations of any public body having jurisdiction for safety of persons or property or to protect them from damage, injury or loss, and shall erect and maintain all necessary safeguards for such safety and protection. Contractor shall notify owners of adjacent property, Underground Facilities, and/or utility owners when prosecution of the Work may affect them, and shall cooperate with them in the protection, removal, relocation, and replacement of their property. All damage, injury, or loss to any property referred to in paragraphs 4.5.2, 4.5.3, or as otherwise provided herein, caused, directly or indirectly in whole or in part, by Contractor, any Subcontractor, Supplier, or other person or organization directly or indirectly employed by any of them to perform or furnish any of the Work, or anyone for whose acts any of them may be liable, shall be remedied by Contractor, except damage or loss attributable to the fault of the Drawings or Specifications, or to the acts or omissions of SWACO. Contractor's duties and responsibilities for safety and for the protection of the Work shall continue until such time as all the Work is completed and Engineer has issued a notice to SWACO and Contractor in accordance with the provisions herein that the Work is acceptable, except as otherwise may be expressly provided in connection with the Supplementary Conditions.

4.9 HAZARDOUS MATERIALS

4.9.1 Contractor shall be responsible for coordinating any exchange of material safety data sheets or other hazard communication information required to be made available to or exchanged between or among employers at the site in accordance with all applicable Laws or Regulations.

4.9.2 In the event Contractor encounters materials reasonably believed to be containing asbestos, polychlorinated biphenyl (PCB), or other hazardous waste or material which has not been rendered harmless, Contractor shall immediately stop Work in the area affected and report the condition to Engineer immediately and provide written notification within twenty-four (24) hours.

4.9.3 The Work in the affected area shall be resumed upon written notice from SWACO to Contractor. If SWACO and Contractor cannot agree as to entitlement, amount, and/or extent of an

adjustment, if any, in Contract Price or extension of the Contract Times as a result of such stoppage of the Work, either party may make a claim as provided in Articles IX and X. The provisions of this paragraph 4.9.3 are not intended to apply to materials uncovered or revealed at the Project which are or could be hazardous waste or materials when such waste materials are identified in the Supplementary Conditions of the Contract Documents.

4.9.4 The term “rendered harmless” shall mean that the level of exposure is less than any applicable exposure standards set forth in OSHA or other applicable regulations.

4.10 EMERGENCIES

4.10.1 In the event of an emergency affecting the safety or protection of persons, the work, property at the Site, or adjacent property thereto, Contractor, without special instruction or authorization from SWACO, shall act to prevent any threatened damage, injury, or loss.

4.10.2 Contractor shall give Engineer prompt written notice if Contractor believes that any significant change in the Work or variation from the Contract Documents has been caused by any action taken in response to an emergency.

4.10.3 If Engineer recommends that a change in the Contract Documents be made or determines that a change in the Contract Documents is required because of any emergency or action taken by Contractor in response to such an emergency, and SWACO agrees, a Work Change Directive or Change Order shall be issued pursuant to the applicable provisions herein which document the consequences of such actions.

4.11 SHOP DRAWINGS AND SAMPLES

4.11.1 Ownership

4.11.1(a) All Shop Drawings, Samples, and Specifications are the property of SWACO.

4.11.1(b) In making copies of the Shop Drawings and Specifications available, SWACO does not confer a license, or grant Work on the Project.

4.11.2 Shop Drawings and Samples

4.11.2(a) Contractor shall submit Shop Drawings to Engineer for review and approval in accordance with the accepted schedule for Shop Drawings and Sample submittals. All submittals shall be identified as Engineer may require and in the specified number of copies. The data shown on the Shop Drawings will be complete with respect to quantities, dimensions, specified performance and design criteria, materials, and similar data in order to show Engineer the materials and equipment Contractor proposes to provide and enable Engineer to review the information for the purposes as provided herein.

4.11.2(b) Contractor shall also submit Samples to Engineer for review and approval in accordance with said accepted schedule of Shop Drawings and Sample submittals. Each Sample will be clearly identified as to material, Supplier, pertinent data such as catalog numbers, the use for which intended, and otherwise as Engineer may require in order to review the submittal for the purposes as provided herein. The numbers of each Sample to be submitted will be as specified in the Specifications.

4.11.2(c) Contractor shall maintain in good order at the Project site one (1) copy of all Drawings, Specifications, Bulletins, Addenda, approved Shop Drawings, catalog data, manufacturer operating and maintenance instructions, certificates, Warranties, Change Orders, Field Orders, Engineer’s interpretations, As-Built Drawings, and all other Contract Documents.

4.11.2(d) Contractor shall at all times permit access to the Contract Documents located at the Project site to authorized representatives of SWACO and the CMT.

4.11.2(e) Shop Drawings, Samples and other submittals shall be provided by the Contractor for any item required by the Contract Documents but not fully described in the drawings and Specifications, unless waived by the Project Engineer, and shall include, without limitation:

- (i) Construction of the various parts, method of joinery, type of material, grade, quality, and thickness of material, alloy of material, profiles of all sections, reinforcement, method of hanging doors or installing windows, anchorage, type and grade of finish.
- (ii) Capacities, types of materials, and performance charts that are pertinent to the materials and performance charts that are pertinent to each item of equipment.
- (iii) Wiring diagrams, control diagrams, schematic diagrams, working and erection dimensions, arrangement and Specifications.
- (iv) Other pertinent technical information and data.

4.11.3 Submittal Procedures

4.11.3(a) Before submitting each Shop Drawing or Sample, Contractor shall have determined and verified:

- (i) all field measurements, quantities, dimensions, specified performance criteria, installations requirements, materials, catalog numbers, and/or similar information;
- (ii) all materials with respect to intended use, fabrication, shipping, handling, storage, assembly, and installation pertaining to the performance of the Work; and
- (iii) all information relative to Contractor's sole responsibilities relating to means, methods, techniques, sequences, and procedures of construction, as well as safety precautions and programs.

Contractor shall also have reviewed and coordinated each Shop Drawing or Sample with other Shop Drawings, Samples, the requirements of the Work and the Contract Documents.

4.11.3(b) Each submittal shall bear a stamp or a specific written indication that Contractor has satisfied its obligations under the Contract Documents with respect to review and approval of that submittal.

4.11.3(c) At the time of each submittal, Contractor shall give Engineer a separate, specific written notice of any variations that the Shop Drawing or Sample submitted may have from the requirements of the Contract Documents. Further, a specific notation shall be made on each Shop Drawing and Sample submitted to the Engineer for review and approval of each such variation.

4.11.3(d) Engineer will review and approve Shop Drawings and Samples in accordance with the schedule of submittals accepted by Engineer. Engineer's review and approval shall be only to determine if the items covered by the submittals will, after installation or incorporation in the Work, conform to the information given in the Contract Documents and be compatible with the design concept of the completed Project as a functioning whole. Engineer's review and approval will not extend to means, methods, techniques, sequences, or procedures of construction (except where said is expressly called for by the Contract Documents), or to safety precautions or programs incident thereto. The review and approval of a separate item will not indicate approval of the assembly in which the item functions. Contractor shall make the corrections as required by Engineer, and shall return the required number of corrected copies of Shop Drawings and submit as required new Samples for review and approval. Contractor shall direct specific attention in writing to revisions other than the corrections called for by Engineer on previous submittals.

4.11.3(e) Engineer's review and approval of Shop Drawings or Samples shall not relieve Contractor from responsibility for any variation from the requirements of the Contract Documents unless Contractor has notified Engineer in writing of each variation at the time of submission and Engineer has given written approval of each such variation by specific written notation thereof incorporated in or accompanying the Shop Drawing or Sample approval. Any approval by

Engineer shall not relieve Contractor from responsibility to comply with the requirements of this section 4.11.3.

4.11.3(f) Where a Shop Drawing or Sample is required by the Contract Documents or the schedule of Shop Drawings and Sample submissions as accepted by Engineer per paragraph 2.2.6.2, any related Work performed prior to Engineer's review and approval of the pertinent submittal shall be at the sole expense and responsibility of Contractor.

4.11.3(G) Form of Submittals. Contractor shall provide a submittal letter and shall stamp and submit shop drawings or other submittals to engineer for review and comment in accordance with the established schedule.

(i) Unless otherwise specified in the Contract Documents, Contractor shall submit one (1) mylar and three (3) prints of all Shop Drawings and four (4) copies of any other submittal.

(ii) Unless otherwise specified in the Contract Documents, Contractor shall prepare one-fourth inch equals one-foot scale drawings of all sheet metal Work with plan and elevation dimensions to specifically locate all duct Work, equipment and HVAC pipe Work, either on the same or separate drawings.

(iii) Contractor will provide the drawings to SWACO and Engineer to specifically locate equipment, piping, conduit and other Work.

4.12 CONTINUING THE WORK

4.12.1 Contractor shall carry on the Work and adhere to the progress schedule during all disputes or disagreements with SWACO. No Work shall be delayed or postponed pending resolution of any disputes or disagreements, except as permitted by Article XIII pertaining to Suspension of Work and Termination or as SWACO and Contractor may otherwise agree to in writing.

4.13 CONTRACTOR'S GENERAL WARRANTY AND GUARANTEE

4.13.1 Contractor warrants and guarantees to SWACO that all Work will be in accordance with the Contract Documents and will not be defective. Contractor's warranty and guarantee hereunder excludes defects or damage caused by:

4.13.1(a) abuse, modification, or improper maintenance or operation by persons other than Contractor, Subcontractors, or Suppliers; or

4.13.1(b) normal wear and tear under normal usage.

4.13.2 Contractor's obligation to perform and complete the Work in accordance with the Contract Documents shall be absolute. None of the following shall constitute an acceptance of Work that is not in accordance with the Contract Documents or be considered a release of Contractor's obligations to perform the Work in accordance with the Contract Documents:

4.13.2(a) observations by Engineer,

4.13.2(b) recommendation of any progress or final payment by Engineer,

4.13.2(c) the issuance of a Certificate of Substantial Completion or any payment by SWACO to Contractor under the Contract Documents,

4.13.2(d) use or occupancy of the Work or any part thereof by SWACO,

4.13.2(e) any acceptance by SWACO or any failure to do so,

4.13.2(f) any review and approval of a Shop Drawing or Sample submittal, or the issuance of a notice of acceptability by Engineer pursuant to the terms contained herein,

4.13.2(g) any inspection, test, or approval by others, or

4.13.2(h) any correction of defective Work by SWACO.

4.14 INDEMNIFICATION

TO THE FULLEST EXTENT PERMITTED BY LAW, AND CONSISTENT WITH OHIO REVISED CODE SECTION 2305.31, THE CONTRACTOR SHALL INDEMNIFY AND HOLD HARMLESS SWACO, ITS TRUSTEES, OFFICERS, CONSULTANTS, AGENTS, REPRESENTATIVES, ATTORNEYS AND EMPLOYEES, IN BOTH INDIVIDUAL AND OFFICIAL CAPACITIES, FROM AND AGAINST ALL CLAIMS, DAMAGES, LOSSES LIENS, CAUSES OF ACTION, SUITS, JUDGMENTS AND EXPENSES (INCLUDING, BUT NOT LIMITED TO, REASONABLE ATTORNEYS' FEES, AND OTHER REASONABLE COSTS), OF ANY NATURE, KIND OR DESCRIPTION, WHICH (A) ARE CAUSED BY OR RESULT FROM THE PERFORMANCE OF THE SERVICES OF CONTRACTOR, ANYONE DIRECTLY OR INDIRECTLY EMPLOYED BY THE CONTRACTOR, ANY CONTRACTOR'S SUB-CONTRACTOR, OR ANYONE FOR WHOSE ACTS THE CONTRACTOR IS LEGALLY LIABLE, AND (B) ARE ATTRIBUTABLE TO BODILY INJURY, PERSONAL INJURY, SICKNESS, DISEASE OR DEATH OF ANY PERSON, OR TO DAMAGE TO OR DESTRUCTION OF PROPERTY, BUT (C) ONLY TO THE EXTENT THEY ARE CAUSED BY ANY NEGLIGENT, RECKLESS OR WILLFUL ACT, ERROR OR OMISSION OF THE CONTRACTOR, ANYONE DIRECTLY OR INDIRECTLY EMPLOYED BY THE CONTRACTOR, ANY CONTRACTOR'S SUB-CONTRACTOR, OR ANYONE FOR WHOSE ACTS THE CONTRACTOR IS LEGALLY LIABLE. THE TERM, CONDITIONS AND PROVISIONS OF THIS PARAGRAPH SHALL SURVIVE THE TERMINATION OF THIS AGREEMENT FOR ANY REASON.

4.15 SURVIVAL OF OBLIGATIONS.

All representations, indemnifications, warranties, and guarantees made in, required by, or given in accordance with the Contract Documents, as well as all continuing obligations indicated in the Contract Documents, will survive final payment, completion, and acceptance of the Work and termination or completion of the Agreement.

ARTICLE V OTHER WORK

5.1 RELATED WORK AT SITE.

SWACO may perform other work related to the Project at the Site, or through direct contracts with others or utility owners. If other such work is to be performed and was not noted in the Contract Documents, then (i) written notice thereof will be given to Contractor prior to starting any other such work, and (ii) Contractor may make a claim therefor as provided herein if Contractor believes that such performance will involve additional expense to Contractor or requires additional time and the parties are unable to agree as to the amount or extent thereof.

5.1.1 Contractor shall afford each other contractor and utility owner proper and safe access to the Site and a reasonable opportunity for the introduction and storage of materials and equipment, the execution of such other work, and shall properly connect and coordinate the Work with theirs. Unless otherwise provided in the Contract Documents, Contractor shall do all the cutting, fitting, and patching of the Work that may be required to make its parts come together properly and integrate with other such work. Contractor shall not endanger any work of others by cutting, excavating, or otherwise altering their work, and will only do so with the written consent of Engineer and the others whose work is to be affected. The duties and responsibilities of Contractor under this paragraph are for the benefit of such utility owners and other contractors to the extent that there are comparable provisions for the benefit of Contractor in SWACO's contracts with other such contractors or utility owners.

5.1.2 If the proper execution or results of any part of Contractor's Work depends upon work performed by others under this Article V, Contractor shall inspect such other work and promptly report

to Engineer in writing any delays, defects, or deficiencies in such other work that render it unavailable or unsuitable for the proper execution and results of Contractor's Work. Contractor's failure to so report will constitute an acceptance of other such work as fit and proper for integration with Contractor's Work, except for latent defects and deficiencies in such other work.

5.1.3 If SWACO contracts with others for the performance of other work on the Project at the site, the following will be set forth in the Supplementary Conditions:

5.1.3(a) identification of the person, firm, or corporation who will have authority and responsibility for coordination of the activities among the various prime contractors;

5.1.3(b) itemization of the specific matters to be covered by such authority and responsibility; and

5.1.3(c) the extent of such authority and responsibilities will be provided.

Unless otherwise provided in the Supplementary Conditions, SWACO shall have sole authority and responsibility in respect of such coordination.

ARTICLE VI OWNER'S RESPONSIBILITIES

6.1 Except as otherwise provide in these General Conditions, SWACO shall issue all communications to Contractor through Engineer.

6.2 In case of termination of the employment of Engineer, SWACO shall appoint an engineer against whom Contractor shall make no reasonable objections, whose status under the Contract Documents shall be that of the former Engineer.

6.3 SWACO shall furnish the data required under the Contract Documents promptly and shall make payments to Contractor when they are due pursuant to SWACO's Accounts Payable policies and the terms as stated herein. In the event that the terms herein conflict with the referenced policies, the SWACO Accounts Payable policies shall govern.

6.4 SWACO's shall not supervise, direct, or have control or authority over, nor be responsible for, Contractor's means, methods, techniques, sequences, or procedures of construction, or the safety precautions and programs incident thereto, or for any failure of Contractor to comply with the applicable Laws and Regulations relating to the furnishing or performance of the Work. SWACO shall not be responsible for Contractor's failure to perform or furnish the Work in accordance with the Contract Documents.

ARTICLE VII ENGINEER'S STATUS DURING CONSTRUCTION

7.1 Engineer will be SWACO's representatives during the construction period. The duties, responsibilities, and limitations of authority of Engineer as SWACO's representative during construction are set forth in the Contract Documents and will not be changed without the written consent of SWACO and Engineer.

7.2 Engineer will make visits to the Site at intervals appropriate to the various stages of construction as Engineer deems necessary in order to observe as an experienced and qualified design professional the progress that has been made and the quality of the various aspects of Contractor's executed Work. Based on information obtained during such visits and observations, Engineer will endeavor for the benefit of SWACO to determine, in general, if the Work is proceeding in accordance with the Contract Documents. Engineer will not be required to make exhaustive or continuous on-site inspections to check the quality or quantity of the Work. Engineer's efforts will be directed toward providing SWACO a greater degree of confidence that the completed Work will conform generally to the Contract Documents. On the basis of

such visits and observations, Engineer will keep SWACO informed of the progress of the Work and will endeavor to guard SWACO against defective Work.

7.2.1 Should SWACO so request, Engineer shall furnish a Project Representative to assist Engineer in providing more continuous observation of the Work. The responsibilities, authority, and limitations thereon of any such Project Representative and assistants will be as provided herein and in the Supplementary Conditions. If SWACO designates another representative or agent to represent SWACO at the site who is not Engineer's Consultant, agent, or employee, the responsibilities, authority, and limitations thereon of other such person will be as provided in the Supplementary Conditions.

7.3 Engineer's visits and on-site observations are subject to all of the limitations on Engineer's authority and responsibility set forth in this Article VII and particularly, but without limitation, during or as a result of Engineer's on-site visits or observations of Contractor's Work, Engineer will not supervise, direct, control, or have authority over or be responsible for Contractor's means, methods, techniques, sequences, or procedures of construction, or the safety precautions and programs incident thereto, or for any failure of Contractor to comply with federal, State and local Laws, rules, and regulations applicable to the furnishing or performance of the Work.

7.4 CLARIFICATIONS AND INTERPRETATIONS. Engineer will issue with reasonable promptness such written clarifications or interpretations of the requirements of the Contract Documents (in the form of Drawings or otherwise) as Engineer may determine necessary, which shall be consistent with the intent of and reasonably inferable from the Contract Documents. Such written clarifications and interpretations will be binding on SWACO and Contractor. If SWACO or Contractor believes that a written clarification or interpretation justifies an adjustment to the Contract Price or Contract Times, or both, and the parties are unable to agree to the amount or extent thereof, if any, SWACO or Contractor may make a written claim therefor pursuant to the terms as provided herein.

7.5 AUTHORIZED VARIATIONS IN THE WORK. Engineer may authorize minor variations in the Work from the requirements of the Contract Documents which do not involve an adjustment in the Contract Price or the Contract Times and are compatible with the design concept of the completed Project as a functioning whole as indicated by the Contract Documents. These may be accomplished by a Field Order and will be binding on SWACO and Contractor, who shall perform the Work involved promptly. If SWACO or Contractor believes that a Field Order justifies an adjustment in the Contract Price or Contract Times, and the parties are unable to agree as to the amount or extent thereof, SWACO or Contractor may make a written claim pursuant to the terms as provided herein.

7.6 REJECTING DEFECTIVE WORK. Engineer will have authority to disapprove or reject Work, which Engineer believes to be defective, or Project Engineer believes will not produce a completed Project that conforms to the Contract Documents or that will prejudice the integrity of the design concept of the completed Project as a functioning whole as indicated by the Contract Documents. Engineer shall also have the authority to require special inspection or testing of the Work as provided herein, whether or not the Work is fabricated, installed, or completed.

7.7 DETERMINATIONS FOR UNIT PRICES. Engineer will determine the actual quantities and classifications of Unit Price Work performed by Contractor. Engineer will review with Contractor the Engineer's preliminary determinations on such matters before rendering a written decision thereon (by recommendation of an Application for Payment or otherwise). Engineer's written decision thereon will be final and binding, except as modified by Project Engineer to reflect changed factual conditions or more accurate data, upon SWACO and Contractor, subject to the provisions of the Dispute Resolution Procedures of these General Conditions or as otherwise agreed.

7.8 Engineer will be the interpreter of the requirements of the Contract Documents and shall determine the acceptability of the Work in relation to the requirements of the Contract Documents. Claims, disputes, and other matters relating to the performance, furnishing, or acceptability of the Work, the quantities and classifications of Unit Price Work, the interpretation of the requirements of the Contract Documents

pertaining to whether the performance of the Work is in accordance with the Contract Documents, and claims seeking changes in the Contract Price or Contract Times will be referred initially to the Project Engineer in accordance with the terms of these General Conditions.

7.8.1 When functioning as interpreter under paragraph 7.8, Engineer will not show partiality to the positions taken by SWACO or Contractor and will not be liable in connection with any interpretation or decision rendered in good faith in such capacity. To the extent provided by the General Conditions, the rendering of a decision by Engineer with respect to any claim, dispute or other matter relating to the performance, furnishing, or acceptability of the Work, the quantities and classifications of Unit Price Work, the interpretation of the requirements of the Contract Documents pertaining to performance of the Work, and claims seeking changes in the Contract Price or Contract Times (except any which have been waived by the making or acceptance of final payment), will be a condition precedent to any exercise by SWACO or Contractor of such rights or remedies as either may otherwise have under the Contract Documents or by any such Laws or Regulation regarding any such claim or dispute.

7.8.2 Notwithstanding any other provision set forth in the Contract Documents, no interpretation, decision, or recommendation of Engineer which results in a Change Order due to a change in Contract Price or other change in the Contract Documents which SWACO's Executive Director, at his sole and complete discretion, determines requires the issuance of a Change Order, shall be binding upon SWACO unless and until such Change Order has been approved by SWACO's Board of Trustees in accordance with SWACO's by-laws, rules, and/or procurement policy.

7.9 Neither Engineer's authority or responsibility under any provision of the Contract Documents, nor any decision made by Engineer in good faith, shall create, impose, or give rise to any duty owed by Engineer to Contractor, any Subcontractor, any Supplier, any other person or organization other than SWACO, or to any surety for, or employee or agent of any of them.

7.10 Engineer will not supervise, direct, control, or have authority over or be responsible for Contractor's means, methods, techniques, sequences, or procedures of construction, or the safety precautions and programs incident thereto, or for any failure of Contractor to comply with pertinent provisions of federal, State and local laws, rules and regulations applicable to the furnishing or performance of the Work. Engineer shall not be responsible for Contractor's failure to perform or furnish the Work in accordance with the Contract Documents, or for any acts or omissions of Contractor or of any Subcontractor, Supplier, or any other person or organization performing or furnishing any of the Work.

7.11 Engineer's review of the final Application for Payment and accompanying documentation and all maintenance and operating instructions, schedules, guarantees, bonds, certificates of inspection, tests and approvals, and any other documentation required to be delivered by these General Conditions will only be to determine generally that their content complies with the requirements of, and in the case of certificates of inspections, tests, and approvals, that the results certified indicate compliance with the Contract Documents.

ARTICLE VIII CHANGES IN THE WORK

8.1 CHANGE ORDER

8.1.1 Without invalidating the Agreement and without notice to any surety, SWACO may, at any time or from time to time, order additions, deletions, or revisions in the Work. Such additions, deletions, or revisions will be authorized by Written Amendment, a Change Order, or a Work Change Directive. Upon receipt of any such document, Contractor shall promptly proceed with the Work involved which will be performed under the applicable conditions of the Contract Documents, except as otherwise specifically provided.

8.1.1(a) If SWACO and Contractor are unable to agree as to the extent, if any, of an adjustment in the Contract Price or Contract Times that should be allowed under a Work Change Directive, a claim may be made therefor as provided herein.

8.1.2 Except in the case of emergency or a required uncovering of the Work, Contractor shall not be entitled to an increase in Contract Price or an extension of Contract Times without a Written Amendment, a Change Order, or a Work Change Directive. Contractor shall not be entitled to rely upon any alleged course of conduct or verbal instructions as a basis for a change in the Contract Price or Contract Time. If Contractor proceeds with purportedly extra Work without Written Amendment, a Change Order, or a Work Change Directive it does so at its own risk.

8.1.3 SWACO and Contractor shall execute appropriate Change Orders recommended by Engineer, or Written Amendments covering:

8.1.3(a) changes in the Work which are (i) ordered by SWACO pursuant to paragraph 8.1.1, (ii) required because of acceptance of defective Work or correcting defective Work under the terms herein, or (iii) agreed to by the parties;

8.1.3(b) changes in the Contract Price or Contract Times which are agreed to by the parties;

8.1.3(c) changes in the Contract Price or Contract Times which embody the substance of any written decision rendered by Engineer pursuant to paragraph 7.8;

Provided that, in lieu of executing any such Change Order, an appeal may be taken from any such decision in accordance with the provisions of the Contract Documents and applicable Laws and Regulations, but during any such appeal, Contractor shall carry on the Work and adhere to the progress schedule as provided herein.

8.1.4 If any notice of any change affecting the general scope of the Work or the provisions of the Contract Documents, including, but not limited to, Contract Price or Contract Times, is required by the provisions of any Bond to be given to a surety, the giving of such notice shall be Contractor's responsibility, and the amount of each applicable Bond will be adjusted accordingly.

ARTICLE IX CHANGE OF CONTRACT PRICE

9.1 The Contract Price represents the entire and total compensation, subject to authorized adjustments, payable to Contractor for performing the Work. All duties, responsibilities, and obligations assigned to or undertaken by Contractor shall be at Contractor's expense without change in the Contract Price.

9.2 The Contract Price may only be changed by a Change Order or by Written Amendment. Any claim for adjustment in Contract Price shall be based on written notice delivered by the party making the claim to the other party and Engineer promptly, but in no event later than thirty (30) days, after the start of the occurrence or event giving rise to the claim and stating the general nature of the claim. Notice of the amount of the claim with supporting data shall be delivered within sixty (60) days after the start of such occurrence or event, and shall be accompanied by claimant's written statement that the adjustment claimed covers all known amounts to which the claimant is entitled as a result of said occurrence or event. All claims for adjustment in Contract Price shall be determined by Engineer if SWACO and Contractor cannot otherwise agree on the amount involved. No claim for adjustment of the Contract price will be valid if not submitted in accordance with this paragraph.

9.3 The value of any Work covered by a Change Order or of any claim for an adjustment in the Contract Price will be determined as follows:

9.3.1 Where the Work involved is covered by Unit Prices set forth in the Contract Documents, by application of such Unit Prices to the quantities of the Work involved, subject to the provisions governing Unit Price Work;

9.3.2 Where the Work involved is not covered by Unit Prices set forth in the Contract Documents, by a mutually agreed lump sum;

9.3.3 Where the Work involved is not covered by Unit Prices set forth in the Contract Documents and agreement to a lump sum is not reached, on the basis of the Cost of the Work as determined pursuant to the provisions herein.

9.4 Cost of the Work. The term Cost of the Work means the sum of all costs necessarily incurred and paid by Contractor in the proper performance of the Work. Except as otherwise may be agreed to in writing by SWACO, such costs shall be in amounts no higher than those prevailing in the locality of the Project, shall include only the following items and shall not include any of the costs itemized in paragraph 9.5:

9.4.1 Payroll costs for employees in the direct employ of Contractor in the performance of the Work under schedules of job classifications agreed upon by SWACO and Contractor. Such employees shall include superintendents, foremen, and other personnel employed full-time at the site. Payroll costs for employees not employed full-time on the Work shall be apportioned on the basis of their time spent on the Work. The expense of performing Work after regular working hours, on Saturdays, Sundays, or legal holidays shall be included in the above to the extent authorized by SWACO.

9.4.2 Cost of all materials and equipment furnished and incorporated in the Work, including costs of transportation and storage thereof, and Suppliers' field services required in connection therewith. All trade discounts, rebates, refunds, returns from sale of surplus materials and equipment shall accrue to SWACO, and Contractor shall make provisions so that they may be obtained.

9.4.3 Payments made by Contractor to Subcontractors for Work performed or furnished by Subcontractors. If required by SWACO, Contractor shall obtain competitive bids from subcontractors acceptable to SWACO and Contractor, and shall deliver such bids to SWACO who will then determine, with the advice of Engineer, which bids, if any, will be accepted.

9.4.4 Costs of special consultants, including but not limited to engineers, architects, testing laboratories, surveyors, attorneys, and accountants, employed for services specifically related to the Work.

9.4.5 Supplemental costs including the following:

9.4.5(a) The proportion of necessary transportation, travel, and subsistence expenses of Contractor's employees incurred in discharge of duties connected with the Work;

9.4.5(b) Cost, including transportation and maintenance, of all materials, supplies, equipment, machinery, appliances, office, and temporary facilities at the site and hand tools not owned by the workers which are consumed in the performance of the Work;

9.4.5(c) Rentals of all construction equipment and machinery and parts thereof whether rented from Contractor or others in accordance with rental agreements approved by SWACO with the advice of Engineer, as well as the costs of transportation, loading, unloading, installation, dismantling, and removal thereof. The rental of any such equipment shall cease when the use thereof is no longer necessary for the Work.

9.4.5(d) Sales, consumer, use, or similar taxes related to the Work, and for which Contractor is liable, as imposed by laws and Regulations;

9.4.5(e) Deposits lost for causes other than negligence of Contractor, and Subcontractor, or anyone directly or indirectly employed by any of them or for whose acts any of them may be liable;

9.4.5(f) Losses and damages caused by damage to the Work, not compensated by insurance or otherwise, sustained by Contractor in connection with the performance and furnishing of the Work, provided they have resulted from causes other than the negligence of Contractor, any Subcontractor, or anyone directly or indirectly employed by any of them or for whose acts of any of them may be liable;

9.4.5(g) The costs of utilities, fuel, and sanitary facilities at the site;

9.4.5(h) Minor expenses such as telephone service at the site, expressage, and similar petty cash items in connection with the Work;

9.4.5(i) Costs of premiums for additional Bonds and insurance required because of changes in the Work.

9.5 The term Cost of the Work shall not include any of the following:

9.5.1 Payroll costs and other compensation of Contractor's officers, executives, principals, general managers, engineers, architects, estimators, attorneys, auditors, accountants, and other personnel employed by Contractor whether at the site or in Contractor's principal or branch office for general administration of the Work and not specifically included in the agreed upon schedule of job classifications;

9.5.2 Expenses of Contractor's principal and branch offices other than Contractor's office at the site;

9.5.3 Any part of Contractor's capital expenses, including interest on Contractor's capital employed for the Work and charges against Contractor for delinquent payments;

9.5.4 Cost of premiums for all Bonds and for all insurance whether or not Contractor is required by the Contract Documents to purchase and maintain the same;

9.5.5 Costs due to the negligence of Contractor, any Subcontractor, or anyone directly or indirectly employed by any of them or for whose acts any of them may be liable, including but not limited to, the correction of defective Work, disposal of materials, equipment wrongly supplied, and making good any damage to property;

9.5.6 Other overhead or general expense costs of any kind and the costs of any item not specifically and expressly included in paragraph 8.4.

9.6 Whenever the Cost of Work is to be determined pursuant to paragraphs 9.4 and 9.5, Contractor shall establish and maintain records thereof in accordance with generally accepted accounting practices and submit in form acceptable to Engineer an itemized cost breakdown together with supporting data.

9.7 It is understood that Contractor has included in the Contract price all allowances so named in the Contract Documents and shall cause the Work so covered to be furnished and performed for such sums as may be acceptable to SWACO and Engineer. Contractor agrees that:

9.7.1 the allowances include the cost to Contractor, less any applicable trade discounts, of materials and equipment required by the allowances to be delivered at the site, and all applicable taxes; and

9.7.2 Contractor's costs for unloading and handling on site, labor, installation costs, overhead, profit, and other expenses contemplated for the allowances have been included in the Contract Price and not in the allowances and no demands for additional payment on account of any of the foregoing will be valid.

Prior to final payment, an appropriate Change Order will be issued as recommended by Engineer to reflect actual amounts due Contractor on account of Work covered by allowances, and the Contract Price shall be accordingly adjusted.

9.8 Unit Price Work. Where the Contract Documents provide that all or part of the Work is to be Unit Price Work, initially the Contract Price will be deemed to include for all Unit Price Work an amount equal to the sum of the established unit price for each separately identified item of Unit Price Work times the estimated quantity of each item as indicated in the Agreement. The estimated quantities of items of Unit Price Work are not guaranteed and are solely for the purpose of comparison of Bids and determining an initial Contract Price. Determinations of the actual quantities and classifications of Unit Price Work performed by Contractor will be made by Engineer in accordance with the provisions as contained herein.

9.8.1 Each unit price will be deemed to include an amount considered by Contractor to be adequate to cover Contractor's overhead and profit for each separately identified item.

9.8.2 SWACO or Contractor may make a claim for an adjustment in the Contract Price in accordance with this Article if:

9.8.2(a) the quantity of any item of Unit Price Work performed by Contractor differs materially and significantly from the estimated quantity of such item indicated in the Agreement; and

9.8.2(b) there is no corresponding adjustment with respect to any other item of Work; and

9.8.2(c) if Contractor believes that Contractor is entitled to an increase in Contract Price as a result of having incurred additional expense or Owner believes that Owner is entitled to a decrease in Contract Price and the parties are unable to agree as to the amount of any such increase or decrease.

ARTICLE X CHANGE OF CONTRACT TIMES

10.1 The Contract Times (or Milestones) may only be changed by a Change Order or Written Amendment. Any claim for adjustment of the Contract Times (or Milestones) shall be based on written notice delivered by the party making the claim to the other party and to Engineer promptly, but in no event later than thirty (30) days after the occurrence of the event giving rise to the claim and stating the general nature of the claim. Notice of the extent of the claim with supporting documentation shall be delivered within sixty (60) days after such occurrence, and shall be accompanied by the claimant's written statement that the adjustment claimed is the entire adjustment to which claimant has reason to believe it is entitled as a result of the occurrence or event. All claims for adjustments in the Contract Times (or Milestones) shall be determined by Engineer in accordance with the provisions as contained herein if SWACO and Contractor cannot agree. No claim for an adjustment in the Contract Times (or Milestones) will be valid if not submitted in accordance with the requirements of this paragraph.

10.2 All time limits stated in the Contract Documents are of the essence of the Agreement.

10.3 Where Contractor is prevented from completing any part of the Work within the Contract Times (or Milestones) due to delay beyond the control of the Contractor, the Contract Times (or Milestones) will be extended an amount equal to the time lost due to such delay if a claim is made thereunder as provided in paragraph 10.1. Delays beyond the control of Contractor shall include, but not be limited to, acts or neglect by SWACO, acts or neglect of utility owners or other contractors performing other work as contemplated herein, fires, floods, epidemics, abnormal weather conditions, or acts of God. Delays attributable to and within the control of a Subcontractor or Supplier shall be deemed to be delays within the control of Contractor.

10.4 Where Contractor is prevented from completing any part of the Work within the Contract Times (or Milestones) due to delay beyond the control of both SWACO and Contractor, an extension of the Contract Times (or Milestones) in an amount equal to the time lost due to such delay shall be Contractor's sole and exclusive remedy for such delay. In no event shall SWACO be liable to Contractor, any Subcontractor, Supplier, or any other person or organization, or to any surety for or employee or agent of any of them, for damages arising out of or resulting from (i) delays caused by or within the control of Contractor, or (ii) delays beyond the control of both parties including but not limited to fires, floods, epidemics, abnormal weather conditions, acts of God, or acts or neglect by utility owners or other contractors performing other work.

**ARTICLE XI
TESTS AND INSPECTIONS; CORRECTION, REMOVAL,
OR ACCEPTANCE OF DEFECTIVE WORK**

11.1 NOTICE OF DEFECTS. Prompt notice of all defective Work of which SWACO or Engineer have actual knowledge will be given to Contractor. All defective Work may be rejected, corrected, or accepted as provided in this Article.

11.2 ACCESS TO WORK. SWACO, Engineer, Engineer's Consultants, other representatives and personnel of SWACO, independent testing laboratories, and governmental agencies with jurisdictional interests will have access to the Work at reasonable times for their inspection, observation, and testing. Contractor shall provide them with proper and safe conditions for such access and advise of Contractor's site safety procedures and programs so that they may comply therewith.

11.3 TESTS AND INSPECTIONS. Contractor shall give engineer timely notice of readiness of the work for all required inspections, tests, or approvals, and shall cooperate with inspection and testing personnel to facilitate required inspections or tests.

11.4 SWACO shall employ and pay for the services of an independent testing laboratory to perform all inspections, tests, or approvals required by the contract documents except:

11.4.1 inspections, tests, or approvals covered by paragraph 11.5 below;

11.4.2 costs incurred in connection with tests or inspections conducted pursuant to paragraph 11.9 below shall be paid as provided in that paragraph; and

11.4.3 as otherwise specifically provided in the Contract Documents.

11.5 If Laws or Regulations of any public body having jurisdiction require any Work (or any part thereof) specifically to be inspected, tested, or approved, Contractor shall assume full responsibility for arranging and obtaining such inspections, tests, or approvals, pay all costs in connection therewith, and furnish Engineer the required certificates of inspection or approval. Contractor shall also be responsible for arranging and obtaining, and shall pay all costs in connection with, any inspections, tests, or approvals required for SWACO's and Engineer's acceptance of materials or equipment to be incorporated within the Work, or of materials, mix designs, or equipment submitted for approval prior to Contractor's purchase thereof for incorporation in the Work.

11.6 If any Work or the work of others that is to be inspected, tested, or approved is covered by Contractor without written concurrence of Engineer, it must, if requested by Engineer, be uncovered for observation.

11.7 Uncovering Work as provided in 11.8 shall be at Contractor's expenses unless Contractor has given engineer timely notice of Contractor's intent to cover same and Engineer has not acted with reasonable promptness in response to such notice.

11.8 UNCOVERING THE WORK. If any Work is covered contrary to the written request of Engineer, it must, if requested by Engineer, be uncovered for Engineer's observation and replaced at Contractor's expense.

11.8.1 If Engineer considers it necessary or advisable that covered Work be observed by Engineer or inspected or tested by others, Contractor, at Engineer's request, shall uncover, expose, or otherwise make available for observation, inspection, or testing as Engineer may require, that portion of the Work in question, furnishing all necessary labor, materials, and equipment.

11.8.1(a) If it is found that such Work is defective, Contractor shall pay all claims, costs, losses, and damages caused by, arising out of, or resulting from such uncovering, exposure, observation, inspection and testing, and of the satisfactory replacement or reconstruction, including but not limited to all costs of repair or replacement of the work of others. SWACO shall thus be entitled

to an appropriate decrease in the Contract Price, and, if the parties are unable to agree as to the amount thereof, may make a claim as provided for herein.

11.8.1(b) If such Work is not found to be defective, Contractor shall be allowed an increase in the Contract Price or an extension of the Contract Times (or Milestones), or both, directly attributable to such uncovering, exposure, observation, testing, inspection, replacement, and reconstruction. If the parties are unable to agree as to the amount or extent thereof, Contractor may make a claim therefor as provided herein.

11.9 OWNER MAY STOP THE WORK. If the Work is defective, or Contractor fails to supply sufficient skilled workers, suitable materials or equipment, or fails to furnish or perform the Work in such a way that the completed Work will conform to the Contract Documents, SWACO may order Contractor to stop the Work, or any portion thereof, until the cause for such order has been eliminated; however, this right of SWACO to stop the Work shall not give rise to any duty on the part of SWACO to exercise this right for the benefit of Contractor or any surety or other party.

11.10 CORRECTION OR REMOVAL OF DEFECTIVE WORK. If required by Engineer, Contractor shall promptly, as directed, either correct all defective Work, whether or not fabricated, installed, or completed, or if the Work has been rejected by Engineer, remove it from the Site and replace it with Work that is not defective. Contractor shall pay all claims, costs, losses, and damages caused by or resulting from such correction or removal, including but not limited to all costs of repair or replacement of the work of others.

11.11 CORRECTION PERIOD. If within one (1) year after the date of Substantial Completion or such longer period of time as may be prescribed by Laws or regulations, or by the terms of any applicable special guarantee required by the Contract Documents, any Work is found to be defective, Contractor shall promptly, without cost to SWACO and in accordance with SWACO's written instructions:

11.11.1 correct such defective Work or, if it has been rejected by SWACO, remove it from the Site and replace it with Work that is not defective, and

11.11.2 satisfactorily correct or remove and replace any damage to other Work or the work of others resulting therefrom.

If Contractor does not promptly comply with the terms of such instructions, or in an emergency where delay would cause serious risk of loss or damage, SWACO may have the defective Work corrected or the rejected Work removed and replaced, and all claims, costs, losses, and damages caused by or resulting from such removal and replacement shall be paid by Contractor.

11.12 Where defective Work, and damage to other Work resulting therefrom, has been corrected, removed, or replaced under paragraph 11.11, the correction period hereunder with respect to such Work will be extended for an additional period of one (1) year after such correction, removal, or replacement has been satisfactorily completed.

11.13 ACCEPTANCE OF DEFECTIVE WORK. If, instead of requiring the correction or removal and replacement of defective Work, SWACO prefers to accept it, SWACO may do so. Contractor shall pay all claims, costs, losses, and damage attributable to SWACO's evaluation of and determination to accept such defective Work. If any such acceptance occurs prior to Engineer's recommendation of final payment, a Change Order will be issued incorporating the necessary revisions in the Contract Documents with respect to the Work. SWACO shall further be entitled to an appropriate decrease in the Contract Price, and if the parties are unable to agree as to the amount thereof, SWACO may make a claim as provided herein. If the acceptance occurs after such recommendation, an appropriate amount will be paid by Contractor to SWACO.

11.14. SWACO MAY CORRECT THE DEFECTIVE WORK. If Contractor fails within a reasonable time or after written notice from Engineer to correct defective Work or to remove and replace rejected Work as required by Engineer, or if Contractor fails to comply with any provisions of the Contract Documents, SWACO may, after seven (7) days written notice to Contractor, correct and remedy any such deficiency.

In exercising the rights and remedies under this paragraph, SWACO shall proceed expeditiously. In connection with such corrective and remedial action, SWACO may exclude Contractor from all or part of the Site, take possession of all or part of the Work, and suspend Contractor's services related thereto, take possession of Contractor's tools, appliances, construction equipment and machinery at the site and incorporate in the Work all materials and equipment stored at the site or for which SWACO has paid Contractor but which are stored elsewhere.

11.14.1 Contractor shall allow SWACO, SWACO's representatives, agents, and employees, SWACO's other contractors, Engineer, and Engineer's consultants access to the site to enable SWACO to exercise the rights and remedies under this paragraph. All claims, costs, losses, and damages incurred or sustained by SWACO in exercising such rights and remedies will be charged against Contractor and a Change Order will be issued incorporating the necessary revisions in the Contract Documents with respect to the Work, and SWACO shall be entitled to an appropriate decrease in the Contract Price. Such claims, costs, losses, and damages will include but not be limited to all costs of repair or replacement of work of others destroyed or damaged by correction, removal, or replacement of Contractor's defective Work. Contractor shall not be allowed an extension of the Contract Times because of any delay in the performance of the Work attributable to the exercise of SWACO of SWACO's rights and remedies hereunder.

ARTICLE XII PAYMENTS TO COMPLETION

12.1 SCHEDULE OF VALUES. The schedule of values established as provided herein will serve as the basis for progress payments and will be incorporated into a form of Application for Payment acceptable to Engineer. Progress payments on account of Unit Price Work will be based on the number of units completed.

12.2 APPLICATION FOR PROGRESS PAYMENTS. At least twenty (20) days before the date established for each progress payment, but not more than one a month, Contractor shall submit to Engineer for review an Application for Payment filled out and signed by Contractor covering the Work completed as of the date of the Application and accompanied by such supporting documentation as is required by the Contract Documents. If payment is requested on the basis of materials and equipment not incorporated in the Work but delivered and suitably stored at the site or another location agreed to in writing, the Application for Payment shall also be accompanied by a bill of sale, invoice, or other documentation warranting that SWACO has received the materials and equipment free and clear of all Liens and evidence that the materials and equipment are covered by appropriate property insurance and other arrangements to protect SWACO's interest therein, all of which will be satisfactory to SWACO.

12.3 CONTRACTOR'S WARRANTY OF TITLE. Contractor warrants and guarantees that title to all Work, materials, and equipment covered by any Application for Payment, whether incorporated in the Project or not, will pass to SWACO no later than the time of payment free and clear of all Liens.

12.4 REVIEW OF APPLICATIONS FOR PROGRESS PAYMENT. Engineer will, within ten (10) days after receipt of each Application for Payment, either indicate in writing a recommendation of payment and present the Application to SWACO, or return the Application to Contractor indicating in writing Engineer's reasons for refusing to recommend payment. In the latter case, Contractor may make the necessary corrections and resubmit the Application. Ten (10) days after the presentation of the Application of Payment to SWACO with Engineer's recommendation, the amount recommended will become due and when due will be paid by SWACO to Contractor.

12.5 Engineer's recommendation of any payment requested in an Application for Payment will constitute a representation by Engineer to SWACO, based on Engineer's on-site observations of the executed Work as an experienced and qualified design professional and on Engineer's review of the

Application for Payment and the accompanying data and schedules, that to the best of Engineer's knowledge, information, and belief:

12.5.1 the Work has progressed to the point indicated,

12.5.2 the quality of the Work is generally in accordance with the Contract Documents, subject to an evaluation of the Work as a functioning whole prior to or upon Substantial Completion, to the results of any subsequent tests called for in the Contract Documents, to a final determination of quantities and classifications for Unit Price Work, and to any other qualifications stated in the recommendation, and

12.5.3 the conditions precedent to Contractor's being entitled to such payment appear to have been fulfilled insofar as it is Engineer's responsibility to observe the Work. However, by recommending any such payment, Engineer will not thereby be deemed to have represented that:

(i) exhaustive or continuous on-site inspections have been made to check the quality or quantity of Work beyond the responsibilities specifically assigned Engineer in the Contract Documents, or

(ii) that there may not be other matters or issues between the parties that might entitle SWACO to withhold payment from Contractor or entitle Contractor to additional payment by SWACO.

12.6 Engineer's Recommendation of any payment, including final payment, shall not mean that Engineer is responsible for Contractor's means, methods, techniques, sequences or procedures of construction, or the safety precautions and programs incident thereto, or for any failure of Contractor to comply with Laws and Regulations applicable to the furnishing or performance of Work, or for any failure of Contractor to perform or furnish Work in accordance with the Contract Documents.

12.7 Engineer may refuse to recommend the whole or any part of any payment if, in Engineer's opinion, it would be incorrect to make the representation to SWACO referred to in paragraph 12.5. Engineer may also refuse to recommend any such payment, or because of subsequently discovered evidence of the results of inspections or tests, nullify any payment previously recommended, to such extent as may be necessary in Engineer's opinion to protect SWACO from loss due to any of the following:

12.7.1 the Work is defective, or completed Work has been damaged requiring correction or replacement,

12.7.2 the Contract Price has been reduced by Written Amendment or Change Order,

12.7.3 SWACO has been required to correct defective Work or complete Work in accordance with paragraph 11.14, or

12.7.4 Engineer has actual knowledge of the occurrence of any of the events enumerated in paragraphs 13.2.1 through 13.2.4 inclusive.

SWACO may refuse to make payment of the full amount recommended by Engineer because:

12.7.5 Claims have been made against SWACO on account of Contractor's performance or furnishing of the Work,

12.7.6 Liens have been filed in connection with the Work, except where Contractor has delivered a specific Bond satisfactory to SWACO to secure the satisfaction and discharge of such Liens,

12.7.7 There are other items entitling SWACO to a set-off against the amount recommended, or

12.7.8 SWACO has actual knowledge of the occurrence of any of the events enumerated in paragraphs 12.7.1 through 12.7.3 or paragraphs 13.2.1 through 13.2.4 inclusive;

But SWACO must give Contractor immediate written notice, with a copy to Engineer, stating the reasons for such action and promptly pay Contractor the amount so withheld, or any adjustment thereto agreed to by SWACO and Contractor, when Contractor corrects to SWACO's satisfaction the reasons for such action.

12.8 SUBSTANTIAL COMPLETION. When Contractor considers the entire Work ready for its intended use, Contractor shall notify SWACO and Engineer in writing that the entire Work is substantially complete, except for those items specifically listed by Contractor as incomplete, and request Engineer issue a certificate of Substantial Completion. Within a reasonable time thereafter, but in no event later than seven (7) days thereafter, SWACO, Contractor, and Engineer shall make an inspection of the Work to determine the status of completion.

12.8.1 If Engineer does not consider the Work substantially complete, Engineer shall notify Contractor in writing giving the reasons therefor.

12.8.2 If Engineer considers the Work substantially complete, Engineer shall prepare and deliver to SWACO a tentative certificate of Substantial Completion which shall fix the date of Substantial Completion. Attached to the certificate shall be a tentative list of items to be completed or corrected before final payment.

12.8.3 SWACO shall have seven (7) days after the receipt of the tentative certificate during which to make written objection to Engineer as to any of the provisions of the certificate or attached list. If, after considering such objections, Engineer concludes that the Work is not substantially complete, Engineer will within fourteen (14) days after submission of the tentative certificate to SWACO notify Contractor in writing, stating the reasons therefor.

12.8.4 If, after consideration of SWACO's objections, Engineer considers the Work substantially complete, Engineer will within said fourteen (14) days execute and deliver to SWACO and Contractor a definitive certificate of Substantial Completion, with a revised list of tentative list of items to be completed or corrected, reflecting such changes from the tentative certificate as Engineer believes justified after consideration of any objections from SWACO.

12.8.5 At the time of delivery of the tentative certificate of Substantial Completion, Engineer shall deliver to SWACO and Contractor a written recommendation as to division of responsibilities pending final payment between SWACO and Contractor with respect to security, operation, safety, maintenance, heat, utilities, insurance, and warranties and guarantees. Unless SWACO and Contractor agree otherwise in writing and so inform Engineer in writing prior to Engineer's issuance of the definitive certificate of Substantial Completion, Engineer's aforesaid recommendation will be binding on SWACO and Contractor until final payment.

12.9 SWACO shall have the right to exclude Contractor from the Work after the date of Substantial Completion, but SWACO shall allow Contractor reasonable access to complete or correct items on the tentative list.

12.10. PARTIAL UTILIZATION. Use by SWACO at SWACO's option of any substantially completed part of the Work which: (i) has specifically been identified in the Contract Documents, or (ii) SWACO, Engineer, and Contractor agree constitutes a separately functioning and usable part of the Work that can be used by SWACO for its intended purpose without significant interference with Contractor's performance of the remainder of the Work, may be accomplished prior to Substantial Completion of all the Work subject to the following:

12.10.1 SWACO may at any time request in writing that Contractor permit SWACO to use any such part of the Work which SWACO believes to be ready for its intended use and substantially complete. If Contractor agrees that such part of the Work is substantially complete, Contractor shall certify to SWACO and Engineer that such part of the Work is substantially complete and request Engineer to issue a certificate of Substantial Completion for that part of the Work. Contractor may at any time notify SWACO and Engineer in writing that Contractor considers any such part of the Work ready for its intended use and substantially complete and request Engineer to issue a certificate of Substantial Completion for that part of the Work. Within a reasonable time after either such request, but in no event later than seven (7) days, SWACO, Contractor, and Engineer shall make an inspection of that part of the Work to determine its status of completion. If Engineer does not consider that part of the

Work to be substantially complete, Engineer shall notify SWACO and Contractor in writing and give the reasons therefor. If Engineer considers that part of the Work to be substantially complete, the provisions of paragraphs 12.8 and 12.9 shall apply with respect to certification of Substantial Completion of that part of the Work and the division of responsibility in respect thereof and access thereto.

12.10.2 No occupancy or separate operation of part of the Work shall be accomplished prior to compliance with the requirements of the paragraph herein as related to property insurance.

12.11 FINAL INSPECTION. Upon written notice from Contractor that the entire Work or agreed upon portion thereof is complete, Engineer shall make a final inspection with SWACO and Contractor and shall notify Contractor in writing of all particulars in which this inspection reveals that the Work is incomplete or defective. Contractor shall immediately take such measures as are necessary to complete such Work or remedy such deficiencies.

12.12 FINAL APPLICATION FOR PAYMENT. After Contractor has completed all such corrections to the satisfaction of Engineer and delivered in accordance with the Contract Documents all maintenance and operating instructions, schedules, guarantees, Bonds, certificates or other evidence of insurance as required, certificates of inspection, marked-up record documents, and other documents, Contractor may make application for final payment following the procedure for progress payments. The final Application for Payment shall be accompanied, except as previously delivered, by:

12.12.1 all documentation called for in the Contract Documents, including but not limited to the evidence of insurance as required by the Agreement herein,

12.12.2 consent of the surety, if any, to final payment, and

12.12.3 complete and legally effective releases or waivers which are satisfactory to SWACO of all Liens arising out of or filed in connection with the Work. In lieu of such releases or waivers of Liens and as approved by SWACO, Contractor may furnish receipts or releases in full and an affidavit of Contractor that:

(a) the releases and receipts include all labor, services, materials, and equipment for which a Lien could be filed, and

(b) all payrolls, material, and equipment bills and other indebtedness connected with the Work for which SWACO or SWACO's property might in any way be responsible have been paid or otherwise satisfied.

If any Subcontractor or Supplier fails to furnish such a release or receipt in full, Contractor may furnish a Bond or other collateral satisfactory to SWACO to indemnify SWACO against any Lien.

12.13 FINAL PAYMENT AND ACCEPTANCE. If, on the basis of Engineer's observation of the Work during construction and final inspection, and Engineer's review of the final Application for Payment and accompanying documentation as required by the Contract Documents, Engineer is satisfied that the Work has been completed and Contractor's other obligations under the Contract Documents have been fulfilled, Engineer shall, within ten (10) days of receipt of the final Application for Payment, indicate in writing Engineer's recommendation of payment and present the Application to SWACO for payment. Concurrently, Engineer shall also give written notice to SWACO and Contractor that the Work is acceptable subject to the provisions of paragraph 12.15. Otherwise, Engineer shall return the Application for Payment to Contractor, indicating in writing the reasons for refusing to recommend final payment, in which case Contractor shall make the necessary corrections and resubmit the Application.

12.13.1 Thirty (30) days after the presentation to SWACO of the Application and accompanying documentation, in appropriate form and substance and with Engineer's recommendation and notice of acceptability, the amount recommended by Engineer shall become due and will be paid by SWACO to Contractor.

12.14 If, through no fault of Contractor, final completion of the Work is significantly delayed and Engineer so confirms, SWACO shall, upon receipt of Contractor's final Application for Payment and recommendation of Engineer, and without terminating the Agreement, make payment of the balance due for that portion of the Work fully completed and accepted. If the remaining balance to be held by SWACO for Work not fully completed or corrected is less than the retainage stipulated in the Agreement, and if Bonds have been furnished as required herein, the written consent of the surety to the payment of the balance due for that portion of the Work fully completed and accepted shall be submitted by Contractor to Engineer with the Application for such payment. Such payment shall be made under the terms and conditions governing final payment, except that it shall not constitute a waiver of claims.

12.15 WAIVER OF CLAIMS. The making and acceptance of final payment shall constitute:

12.15.1 a waiver of all claims by SWACO against Contractor, except claims arising from unsettled Liens, from defective Work appearing after final inspection pursuant to paragraph 12.11, from failure to comply with the Contract Documents or the terms of any special guarantees specified therein, or from Contractor's continuing obligations under the Contract Documents, and

12.15.2 a waiver of all claims by Contractor against SWACO other than those previously made in writing and still unsettled.

ARTICLE XIII SUSPENSION OF WORK AND TERMINATION

13.1 SWACO MAY SUSPEND THE WORK. At any time and without cause, SWACO may suspend the Work or any portion thereof for a period of not more than ninety (90) days by notice in writing to Contractor and Engineer which will fix the date on which the work shall be resumed. Contractor shall resume the Work on the date so fixed. Contractor shall be allowed an adjustment in the Contract Price or an extension of the Contract Times, or both, directly attributable to any such suspension if Contractor makes an approved claim therefor as provided in Articles IX and X.

13.2 SWACO MAY TERMINATE. Upon the occurrence of any one or more of the following events:

13.2.1 if Contractor persistently fails to perform the work in accordance with the Contract Documents, including but not limited to, failure to supply sufficient skilled workers or suitable materials or equipment, or failure to adhere to the progress schedule established as adjusted from time to time pursuant to the provisions as contained herein;

13.2.2 if Contractor disregards Laws or Regulations of any public body having jurisdiction;

13.2.3 if Contractor disregards the authority of Engineer, or

13.2.4 if Contractor otherwise violates in any substantial way any provisions of the Contract Documents,

SWACO may, after giving Contractor (and the surety, if any) seven (7) days written notice and to the extent permitted by Laws and Regulations, terminate the services of Contractor, exclude Contractor from the site and take possession of the Work and all of Contractor's tools, appliances, construction equipment and machinery at the site and use the same to the full extent they could be used by Contractor, without liability to Contractor for trespass or conversion, incorporate into the Work all materials and equipment stored at the site or for which SWACO has paid Contractor but which are stored elsewhere, and finish the Work as SWACO may deem expedient. In such case, Contractor shall not be entitled to receive any further payment until the Work is finished. If the unpaid balance of the Contract Price exceeds all claims, costs, losses, and damage sustained by SWACO arising out of or resulting from completing the Work, such excess shall be paid to Contractor. If such claims, losses, costs, and damages exceed such unpaid balance, Contractor shall pay the difference to SWACO. Such claims, costs, losses, and damages incurred by SWACO shall be reviewed by Engineer as to their

reasonableness and when so approved by Engineer, shall be incorporated into a Change Order, provided that when exercising any rights or remedies under this paragraph SWACO shall not be required to obtain the lowest price for the Work performed.

13.2.5 Should a tribunal find that any termination by SWACO under Paragraph 13.2 was improper, then the termination shall be treated as if it were a termination under Paragraph 13.4, below.

13.3 Where Contractor's services have been so terminated by SWACO, the termination shall not affect any rights or remedies of SWACO against Contractor then existing or which may thereafter accrue. Any retention or payment of monies due Contractor by SWACO will not release Contractor from liability.

13.4 Upon seven (7) days' written notice to Contractor and Engineer, SWACO may, without cause and without prejudice to any other right or remedy of SWACO, elect to terminate the Agreement. In such case, Contractor shall be paid, without duplication of any items:

13.4.1 for completed and acceptable Work executed in accordance with the Contract Documents prior to the effective date of termination, including fair and reasonable sums for overhead and profit on such Work;

13.4.2 for expenses sustained prior to the effective date of termination in performing services and furnishing labor, materials, or equipment as required by the Contract Documents in connection with uncompleted Work, plus fair and reasonable sums for overhead and profit on such expenses;

13.4.3 for all claims, costs, losses, and damages incurred in settlement of terminated contracts with Subcontractors, Suppliers, and others;

13.4.4 for reasonable expenses directly attributable to termination.

Contractor shall not be paid on account of loss of anticipated profits, revenue, or other economic loss arising out of or resulting from such termination.

13.5 CONTRACTOR MAY STOP WORK OR TERMINATE. If, through no act or fault of Contractor, the Work is suspended for a period of more than ninety (90) days by SWACO or under a court order or that by any other public authority, or Engineer fails to act on any Application for Payment within thirty (30) days after it is submitted, or SWACO fails for thirty (30) days to pay Contractor any sum finally determined to be due, then Contractor may, upon seven (7) days written notice to SWACO and Engineer, and provided SWACO or Engineer do not remedy such suspension or failure within that time, terminate the Agreement and recover from SWACO payment on the same terms as provided in paragraph 13.4.

13.5.1 In lieu of terminating the Agreement and without prejudice to any other right or remedy, if Engineer has failed to act on any Application for Payment within thirty (30) days after it is submitted, or SWACO has failed for thirty (30) days to pay Contractor for any sum finally determined to be due, Contractor may, upon seven (7) days' written notice to SWACO and Engineer, stop the Work until payment of all such amounts due Contractor. The provisions of this paragraph are not intended to preclude Contractor from making a claim under Articles IX and X for an increase in Contract Price or Contract Times, or otherwise for expenses or damage directly attributable to Contractor's stopping Work as permitted by this paragraph.

ARTICLE XIV DISPUTE RESOLUTION

14.1 If and to the extent that SWACO and Contractor have agreed on the method and procedure for resolving disputes between them that may arise under this Agreement, such dispute resolution method and procedure, if any, shall be set forth herein as an Exhibit or otherwise stated in the Contract Documents. If no such Agreement has been reached, and subject to the other provisions as contained within this Agreement, SWACO and Contractor may exercise such rights or remedies as either may otherwise have under the Contract Documents or by the applicable Laws or Regulations relating to any dispute.

**ARTICLE XV
AUDITS AND RECORDS EXAMINATION**

15.1 SWACO shall have the right to examine all books, records, documents and other data of the Contractor and of the Contractor's Subcontractors and Suppliers related to the bidding, pricing or performance of the Work for any purpose.

15.2 Contractor, Subcontractor, or Supplier, as applicable, shall retain such records and make them available at all reasonable times for inspection, audit and reproduction until the expiration of five (5) years after the date of acceptance of the Project by SWACO.

15.3 To the extent permitted by Ohio Revised Code Section 149.43, and to the extent that the Contractor, Subcontractors, or Suppliers, as applicable, inform SWACO in writing that any documents copied by SWACO are trade secrets, SWACO shall treat such documents as trade secrets of the Contractor, Subcontractors, or Suppliers.

15.3.1 In the event any dispute arises with any other person about whether such other person should be given access to the documents, Contractor, Subcontractors, or Suppliers, as applicable, agree to indemnify SWACO against all costs, expenses, and damages, including without limitation attorneys' fees, incurred by reason of that dispute.

15.4 The right of inspection, audit, and reproduction shall extend to all documents necessary to permit adequate evaluation of the cost of pricing data submitted along with the computations and projections used therein.

15.5 Records which relate to disputes, litigation, or settlement of claims arising out of the performance of the Work shall be made available to SWACO until such dispute, litigation, or claims have been finally decided or settled.

15.6 If the Agreement has been terminated, in whole or in part, the records relating to the Work terminated shall be made available to SWACO for a period of five (5) years from the date of any applicable final settlement.

**ARTICLE XVI
PREVAILING WAGE PAYROLL SUBMITTALS**

16.1 PAYROLL SCHEDULE. Within ten (10) days from the date of the Notice to Proceed, Contractor shall provide SWACO's prevailing wage coordinator with a schedule of dates during the term of the Contract on which wages will be paid to employees for the Project.

16.2 PAYROLL REPORTS

16.2.1 Contractor shall submit payroll reports with each Application for Payment, which reports shall be certified by Contractor that the payroll is correct and complete and the wage rates shown are not less than those required by the Agreement. Contractor shall be responsible for submitting all payroll reports of the Contractor's Subcontractors.

16.2.1(a) Each payroll report shall indicate the period covered and shall include a list containing the name, and address of each employee of Contractor and Contractor's Subcontractors paid for the Work.

16.2.1(b) Each payroll report shall list the number of hours each employee worked each day on the Project during the reporting period, the total hours worked by each employee during each week on the Project, the employee's hourly rate of pay, the employee's job classification, the employee's fringe benefits and all deductions from the employee's wages and net pay. The payroll report shall also list each fringe benefit and state if it is paid as cash to the employee or to a named plan.

16.2.1(c) Contractor and Subcontractors shall also submit apprenticeship agreements for all apprentices utilized on the Project.

16.3 AFFIDAVIT. Before any final payment of funds is made to Contractor, Contractor shall file with SWACO the Affidavit required by Ohio Revised Code Section 4115.07.

ARTICLE XVII MISCELLANEOUS

17.1 GIVING NOTICE. Whenever any provision of the Contract Documents requires the giving of written notice, it will be deemed to have been validly given if delivered in person to the individual, or to a member of the firm or an officer of the corporation for whom it is intended, or if delivered or sent by registered or certified mail, postage prepaid, to the last business address known to the giver of the notice.

17.2 COMPUTATION OF TIME. When any period of time is referred to in the Contract Documents by days, it will be computed to exclude the first and include last day of such period. If the last day of any such period falls on a Saturday, Sunday, or a day made a legal holiday by the law of applicable jurisdiction, such day shall be omitted from the computation.

17.2.1 A calendar day of twenty-four (24) hours measured from midnight to the next midnight shall constitute a day.

17.3 NOTICE OF CLAIM. Should SWACO or Contractor suffer injury or damage to person or property because of any error, act, or omission of the other party, or of any of the other party's employees, agents, or others whose acts the other party is legally liable, claim will be made in writing to the other party within a reasonable amount of time of the first observance of such injury or damage. The provisions of this paragraph 17.3 shall not be construed as a substitute for or a waiver of the provision of any applicable statute of limitations or repose.

17.4 CUMULATIVE REMEDIES. The duties and obligations imposed by these General Conditions and the rights and remedies available hereunder to the parties hereto, and in particular but without limitation, the warranties, guarantees, and obligations imposed upon Contractor, and all of the rights and remedies available to SWACO and Engineer thereunder, are in addition to, and are not construed in any way as a limitation of, any rights and remedies available to any or all parties which are otherwise imposed or applicable pursuant to Laws and Regulations, by special warranty, guarantee, or other provision of the Contract Documents, and the provision of this paragraph will be as effective as if repeated specifically in the Contract Documents in connection with each particular duty, obligation, right, and remedy to which they apply.

17.5 ROYALTIES AND PATENTS

17.5.1 Contractor shall pay all royalties, license fees, and assume all costs incident to the use and/or in the performance of the Work or the incorporation in the Work of any invention, design, process, product, or device which is the subject of patent rights or copyrights held by others.

17.5.2 If Contractor has reason to believe that use of the specified item is subject to patent or copyright protection, Contractor shall immediately notify SWACO.

17.6 ASSIGNMENT OF ANTITRUST CLAIMS. By executing the Agreement, Contractor assigns, conveys, and transfers to SWACO any right, title, and interest to any claims or causes of action it may have or acquire under state or federal antitrust laws relating to any goods, products, or services purchased, procured or rendered to SWACO pursuant to the contract.

17.7 PROJECT IDENTIFICATION SIGN

17.7.1 Unless otherwise specified in the Contract Documents, Contractor shall furnish and erect a Project identification sign within thirty (30) Days from the date of the Notice to Proceed.

17.7.2 The sign shall be maintained in good condition until the completion of the Project at which time it shall be removed by the entity providing same.

17.7.3 Any cost associated with moving or repairing the Project identification sign during the progress of the Project shall be the responsibility of the entity providing same.

17.8 SALES, USE, EXCISE AND PROPERTY TAX. SWACO is exempt from any sales, use, excise and property tax. To the extent sales, use, excise, or any similar tax is imposed on the Contractor in connection with these general Conditions, such will be the sole and exclusive responsibility of the Contractor, and the Contractor will pay such taxes (together with any interest and penalties not disputed with the appropriate taxing authority) whether they are imposed at the time the services are rendered or a later time.

17.9 PROFESSIONAL FEES AND COSTS INCLUDED. Whenever reference is made to “claims, costs, losses, and damages”, it shall include in each case, but not limited to, all fees and charges of engineers, architects, attorneys, and other professionals, and all court, arbitration, or other dispute resolution costs.

17.10 SURVIVAL OF OBLIGATIONS. All representations, indemnifications, warranties, and guarantees made in, required by or given in accordance with the Contract Documents, as well as all continuing obligations indicated in the Contract Documents, will survive final payment, completion and acceptance of the Work and termination or completion of the Contract.

Exhibit E

007. Specifications

- Xylem Godwin CD150S Dri-Prime® Pump
- Godwin CD150S Dri-Prime® Pump, System Curve
- Godwin Variable Frequency Drive

Godwin CD150S Dri-Prime® Pump



The Godwin CD150S Dri-Prime pump is a versatile, general purpose dewatering pump designed for use in the industry's most challenging construction, municipal, industrial and emergency response applications. This rugged pump is ideally suited for tough dewatering jobs, and is the reliable choice for rental solutions.

The CD150S is a member of the Godwin S Series of Smart pumps, equipped with a new generation of Field Smart Technology (FST) for remote monitoring and control. In addition to improved hydraulic efficiency, greater fuel economy, and streamlined serviceability, the CD150S impeller is interchangeable with a Flygt N-Technology non-clog impeller, providing the flexibility to tackle stringy, modern wastewater applications with the same pump.

Specifications

Suction connection	6 in (150 mm) flange
Delivery connection	6 in (150 mm) flange
Max capacity	2290 USGPM (520 m ³ /hr) ¹
Max impeller diameter	11.8 in (300 mm)
Max solids handling	3 in (75 mm)
Max operating temperature	176°F (80°C) ²
Max pressure	91 psi (6.3 bar)
Max suction pressure	58 psi (4.0 bar)
Max casing pressure	138 psi (9.5 bar)
Max operating speed	2200 rpm

¹ Larger diameter pipes may be required for maximum flows.

² Please contact our sales and product support for applications in excess of 80°C (176°F).

Features and benefits

- Interchangeable impellers to tackle a full range of solids handling applications.
- Field Smart Technology (FST) allows the user to monitor & control the pump from anywhere in the world.
- New compressor belt tensioner reduces time to change and adjust belt to approximately 30 minutes.
- New sight glass and measuring stick added to monitor level and quality of mechanical seal oil.
- Improved hydraulic design reduces vibration, maximizes efficiency and fuel economy.
- Diesel Oxidative Catalyst (DOC) technology maximizes available power from diesel engine, and reduces maintenance and downtime.
- Fully automatic priming from dry to 28 ft (8.5 m).
- Venturi priming requires no adjustment or control.
- Available as Open Set or Sound Attenuated Enclosure.
- Standard build engine 4LE2X (EPA Final Tier 4).
- Other engine options available.
- Optional environmentally friendly skid base contains all fluid spills.

Godwin CD150S Dri-Prime® Pump



Suction lift table 1800 rpm

Performance data provided in tables is based on water tests at sea level and 68°F (20 °C) ambient.

Total suction head (ft)	Total delivery head (ft)				
	30	43	56	69	82
	Output (USGPM)				
10	1852	1710	1520	1314	1140
15	1789	1646	1441	1251	1061
20	1741	1567	1361	1172	934
25	1678	1425	1251	1061	823

Performance curve

Pump curve is based on 0 ft (0 m) dynamic suction lift.

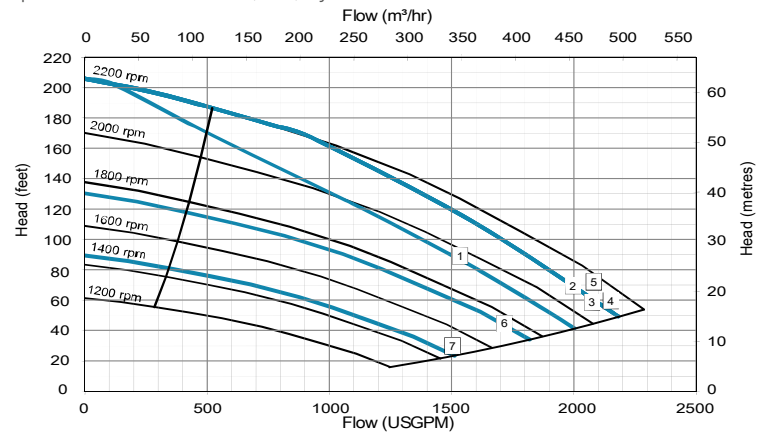

Materials

Pump casing	Cast Iron BS EN 1561/EN-JL1030
Wearplates	Cast Iron BS1561:1997
Pump shaft	Carbon steel BS970:1991 817M40T
Impeller	Cast Steel BS3100 A5 Hardness to 200 HB Brinell
Mechanical seal faces	Silicon carbide Vs Silicon carbide

Driver options

Option	Driver	Power hp (kW)	Energy Use 1800 rpm	Emissions Rating
1	Isuzu 4LE2X	60 (44.8)	2.6 US Gal/hr	EPA FT4
2	JCB TCAE-55	74 (55.2)	3.49 US Gal/hr	EPA FT4
3	John Deere 4045TFC03	74 (55.2)	3.73 US Gal/hr	EPA FT4
4	John Deere 4045T290	74 (57.8)	3.63 US Gal/hr	EPA iT4
5	CAT C4.4M-T	77.5 (57.8)	3.75 US Gal/hr	EPA T3
6	Electric Motor, 4 Pole, 60 Hz	50 (37.3)	59.2 A @ 460V	-
7	Electric Motor, 4 Pole, 50 Hz	40 (29.8)	47.1 A @ 460V	-



Open skidbase trailer mounted

Fuel capacity	60 US Gal (227 L)
Weight dry	2,750 lb (1,250 kg)
Weight wet	3,170 lb (1,440 kg)
Dimensions (L x W x H)	119 in x 66 in x 87 in (3,023 mm x 1,676 mm x 2,210 mm)

Sound attenuated enclosure

Noise @ 7 m (23 ft)	66 dBA
Fuel capacity	80 US Gal (303 L)
Weight dry	3,100 lb (1,410 kg)
Weight wet	3,680 lb (1,670 kg)
Dimensions (L x W x H)	101 in x 43 in x 70 in (2,565 mm x 1,092 mm x 1,778 mm)

GODWIN DRI-PRIME® CD150S ONE (1) PUMP | SYSTEM CURVE BURROW PIT DEWATERING PUMP | SWACO

CD150S

Suction Lift: 14 ft
Suction Pipe: 100 ft 12" DR17 HDPE, (1)45°, (1)Red, (1)Screen

Discharge Head: 29 ft
Discharge Pipe: 400 ft 8" Discharge Hose, (1)Red, (1)CV, (1)GV, (1)Exit Loss

Peak MSL (ft):	875
PAD MSL (ft):	843
HWL MSL (ft):	
LWL MSL (ft):	832
Imp. Eye (ft):	846

Performance - 300 mm Impeller | Variable Speed Curve

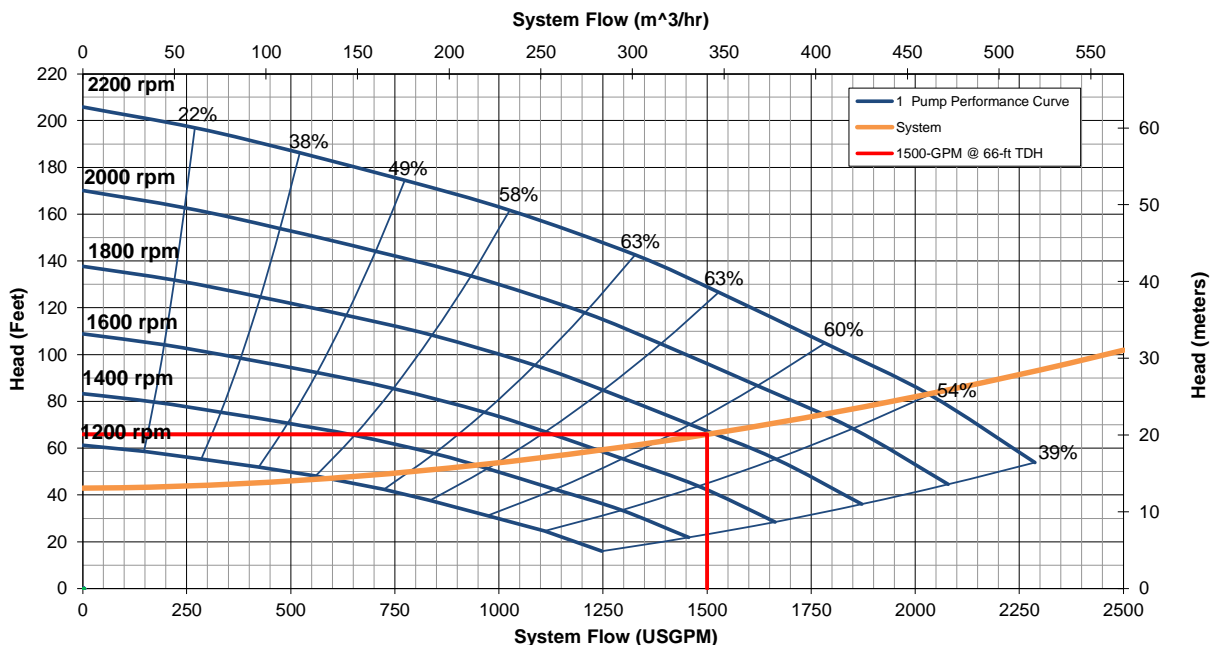

Power

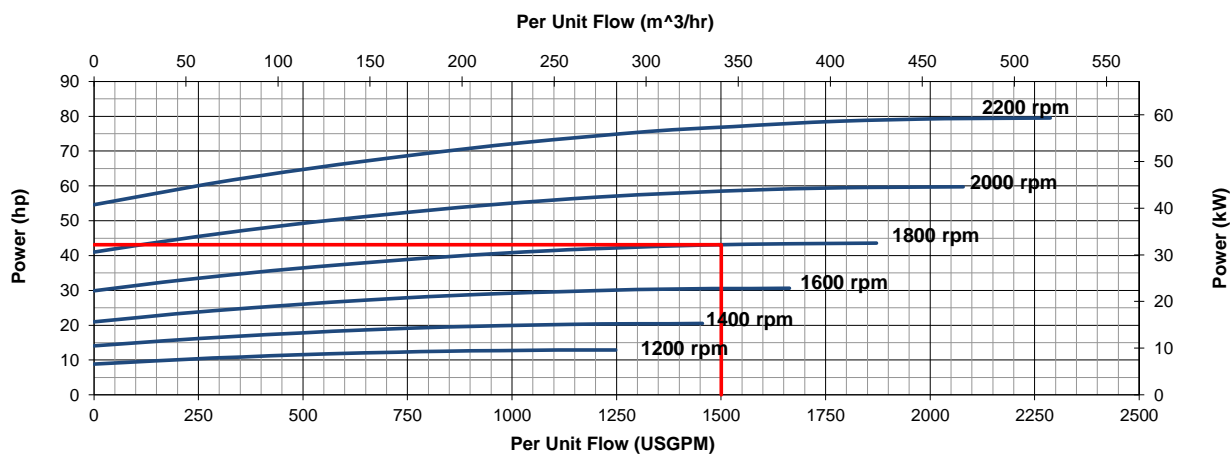

NPSHr

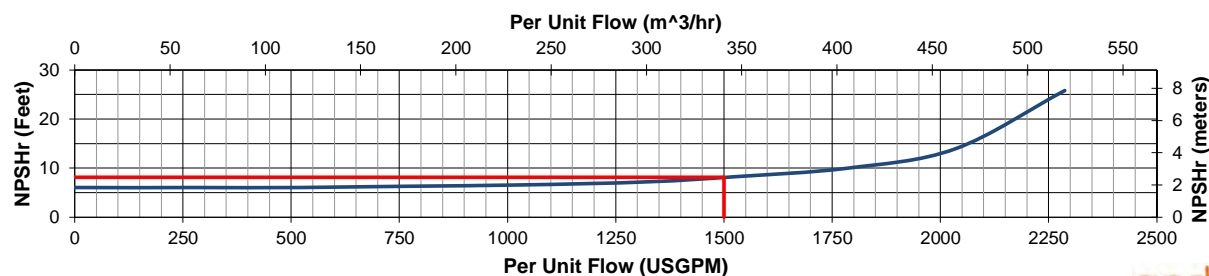

Godwin Variable Frequency Drive

Godwin variable frequency drives are designed to meet the demanding needs of the dewatering market. Available as either rental or sale units, our state-of-the-art variable frequency drive can automatically vary speed to maintain a process variable such as level or pressure. The panel mounted human machine interface (HMI) provides instant process feedback as well as local programming and control. Our VFD's are housed in a NEMA 3R steel enclosure featuring thermostatically controlled ventilation fans and a steel roll cage with lifting bail for stability and protection.

Features

- Microprocessor based "VFD" motor starter, capable of variable speed control
- Input Line Reactor
- Circuit Breaker w/thru-door disconnect
- Analog Input Isolators, with dedicated power supply, for PID
- Thermostat-controlled space heater and ventilation fan
- Fans and exhausts filtered, and covered with matching protective hoods.
- Local-Off-Remote selector switch
- Start and Stop pushbuttons for Local mode
- Potentiometer for setting speed in Local mode
- Drive Running and Drive Fault status lights
- Analog input, 4-20 mA, for PID mode
- Start and Stop inputs for Remote mode
- Dry contacts for monitoring: local mode selected, remote mode selected, Drive Ready, Drive Running, Drive Faulted
- Includes Steel Skid with Lifting Bracket



Keypad

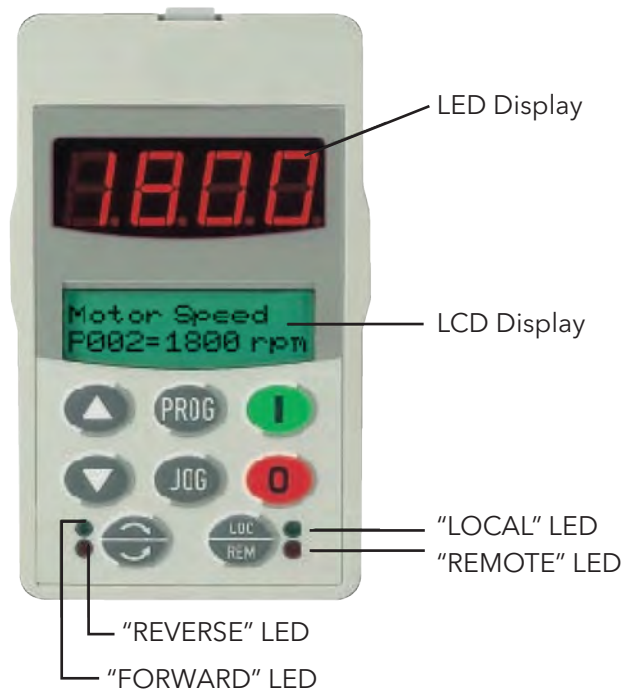

Keypad Options

Intelligent Keypad:

Intelligent operator interface with double display, LED (7 segment) and LCD (2 lines with 16 characters), providing optimum distant viewing along with a detailed description of all parameters and messages.

Selectable Language:

The language of the LCD display messages can be selected by the operator. English, Spanish and Portuguese are available.

Options for Advanced Control Panels

Networkable System:

Link VFDs with other drives and equipment like flowmeters, transducers and diesel pump sets with optional Advanced Control System. View and control an entire system with one central touchscreen.

Remote Access:

Link VFD to web based monitoring page with optional Advanced Control Panel. View the drive status and adjust settings from a remote location with the click of a button.

Specifications

Power		Current	Overall Dimension*		Weight**	
HP	kW	Amps	in x in x in	m x m x m	lb	kg
20	15	30	26 x 45 x 59	0.7 x 1.1 x 1.5	1,000	455
30	22	45	22 x 49 x 66	0.6 x 1.2 x 1.7	1,000	455
50	37	70	30 x 45 x 80	0.8 x 1.1 x 2.0	1,000	455
75	56	105	26 x 55 x 88	0.7 x 1.4 x 2.2	1,100	500
100	75	142	26 x 55 x 88	0.7 x 1.4 x 2.2	1,100	500
150	112	180	26 x 55 x 88	0.7 x 1.4 x 2.2	1,100	500
200	149	240	47 x 53 x 102	1.2 x 1.3 x 2.6	1,840	836
300	224	361	47 x 53 x 102	1.2 x 1.3 x 2.6	2,680	1,218
400	298	515	47 x 53 x 102	1.2 x 1.3 x 2.6	2,660	1,209

*Dimensions with Roll Cage
(D x W x L)

**Includes weight of Roll Cage



© 2014 Xylem, Inc. All rights reserved. Godwin is a trademark of Xylem Inc. or one of its subsidiaries. Godwin is a trademark of Xylem Dewatering Solutions, Inc., a wholly-owned subsidiary of Xylem Inc. Specifications and illustrations are subject to revision without notice. Xylem makes no representation regarding the completeness or accuracy of this information and is not liable for any direct or indirect damages arising from or relating to this information or its use.

www.godwinpumps.com

Dewatering Solutions
84 Floodgate Road
Bridgeport, NJ 08014
Tel +1.856.467.3636
www.godwinpumps.com

Godwin VFD 11.18.14

Exhibit F
008. Construction Plans

West Young Road Electrical Details

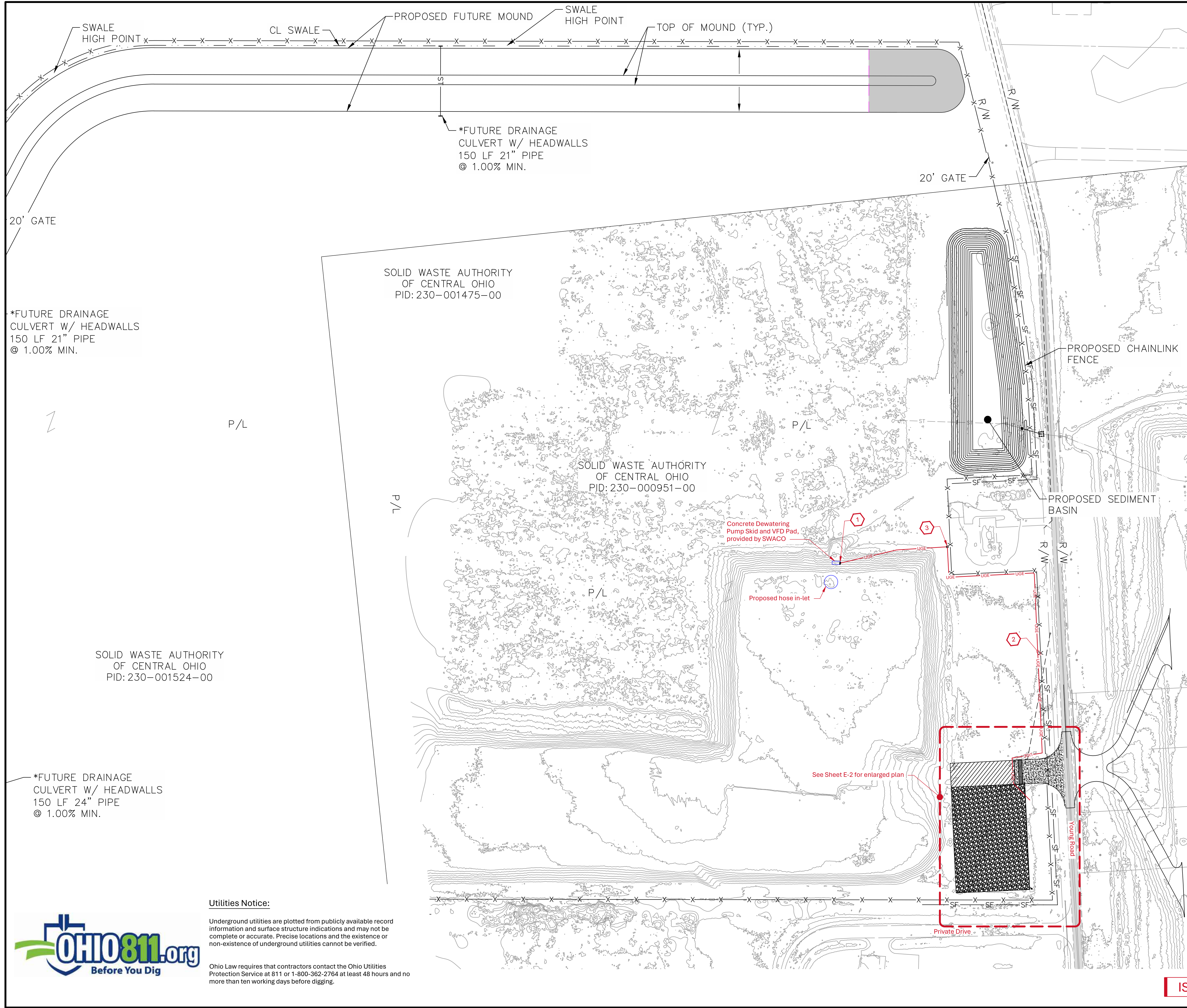

*FUTURE DRAINAGE
CULVERT W/ HEADWALLS
150 LF 21" PIPE
@ 1.00% MIN.

*FUTURE DRAINAGE
CULVERT W/ HEADWALLS
150 LF 24" PIPE
@ 1.00% MIN.

Utilities Notice:

Underground utilities are plotted from publicly available record information and surface structure indications and may not be complete or accurate. Precise locations and the existence or non-existence of underground utilities cannot be verified.

Ohio Law requires that contractors contact the Ohio Utilities Protection Service at 811 or 1-800-362-2764 at least 48 hours and no more than ten working days before digging.



Project Scope of Work:

The scope of this project encompasses installing a new 480Y/277V, 400A, three-phase power service, the installation of a 75 horsepower (maximum) dewatering pump, twelve truck block heater receptacles, a pole-top mounted security camera, wifi access bridge and Ethernet switch. There is an existing AEP overhead three-phase service that will be extended north on Young Road to the new service location. Service conductors will run underground from the AEP service pole to a new service equipment rack.

Site Zoning Information:

Parcel Number: 230-001524-00
Property Class: E - Exempt
Land Use: 620 - Exempt Property Owned by County
Township: Pleasant Township
Parcel Acreage: 58.10

Sheet Index:

- E-1 Overall Power Plan
- E-2 Enlarged Power Plan
- E-3 Electrical Details 1
- E-4 Electrical Details 2

Pump and VFD Specifications:

The Electrical Contractor shall be responsible for providing the dewatering pump and variable-frequency drive and making all necessary arrangements for their installation. SWACO will provide a concrete pad as shown on the plan for installation of the pump skid, pump VFD skid and disconnect rack, along with a temporary gravel access road.

Basis-of-Design:

1. Godwin CD150S Dri-Prime Pump, 75 HP Weight:
2. Godwin Variable Frequency Drive, NEMA 3R Roll Cage Enclosure Weight:

Product Submittals:

Provide submittal package to SWACO and Engineer for approval. Submittals shall be submitted on Contractor company letterhead and contain manufacturer cutsheets that are clearly marked indicating exact model equipment to be provided.

Provide submittals for the following equipment:

- Conductors
- Raceways
- Disconnects
- Panelboards
- Transformers
- Truck Heater Power Pedestals
- Site Lights and Light Poles

General Design Notes:

- A. The Electrical Contractor shall be responsible for complying with all applicable Federal, State and Local Code requirements, including, but not limited to, OBC 27 and NFPA 70.
- B. The locations of underground utilities shown are based on above ground structures and record drawings provided to the Engineer and are not necessarily complete or accurate. The Electrical Contractor is responsible for the final location, support, protection and restoration of all existing utilities and appurtenances whether shown on these drawings or not.
- C. All dimensions and tie-ins shall be field verified by the Electrical Contractor before proceeding with any work.
- D. Protect all existing construction, utilities and facilities to remain. Any and all damage during construction and demolition shall be repaired to match existing conditions.
- E. It is solely the responsibility of the Electrical Contractor to follow all applicable safety codes and regulations during construction. Neither the Owner, nor the Engineer are engaged in or supervise construction.
- F. In general, existing equipment and conditions are shaded and new work is shown in **BOLD**.
- G. Maximum conductor sizes listed have been determined using 75°C termination and insulation assumptions. The Electrical Contractor shall be responsible for verifying that all equipment installed is rated for 75°C and shall make conductor size adjustments according to NEC 110.14(C), as required.

Coded Design Notes:

1. Provide free-standing disconnect rack according to Detail 3 on Sheet E-4.
2. Provide 3" Sch 40 PVC conduit with pullstring. Route underground raceway tight to fence.
3. Provide 12" x 18" polymer concrete in-ground junction box for future extension of circuit.

ISSUED FOR BID



Affinity Infrastructure, LLC
200 East Campus View Blvd
Suite 200
Columbus, OH 43235
AffinityInfrastructure.com

MARK	DATE	REVISION DESCRIPTION

MARK	DATE	REVISION DESCRIPTION

Client:
SWACO
FROM WASTE TO RESOURCES

Project Name:
West Young Rd Electrical Upgrades

Project Address:
6153 Young Rd.
Grove City, OH 43123

Project Number:	24007
Date:	2025.08.15
Engineer:	RMJ
Designer:	RMJ
Drafter:	RMJ
Copyright:	2025

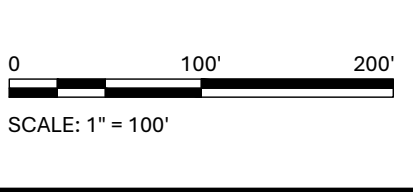

Sheet Name:
Overall Power Plan

Sheet Number:
E-1
Sheet 01 of 04

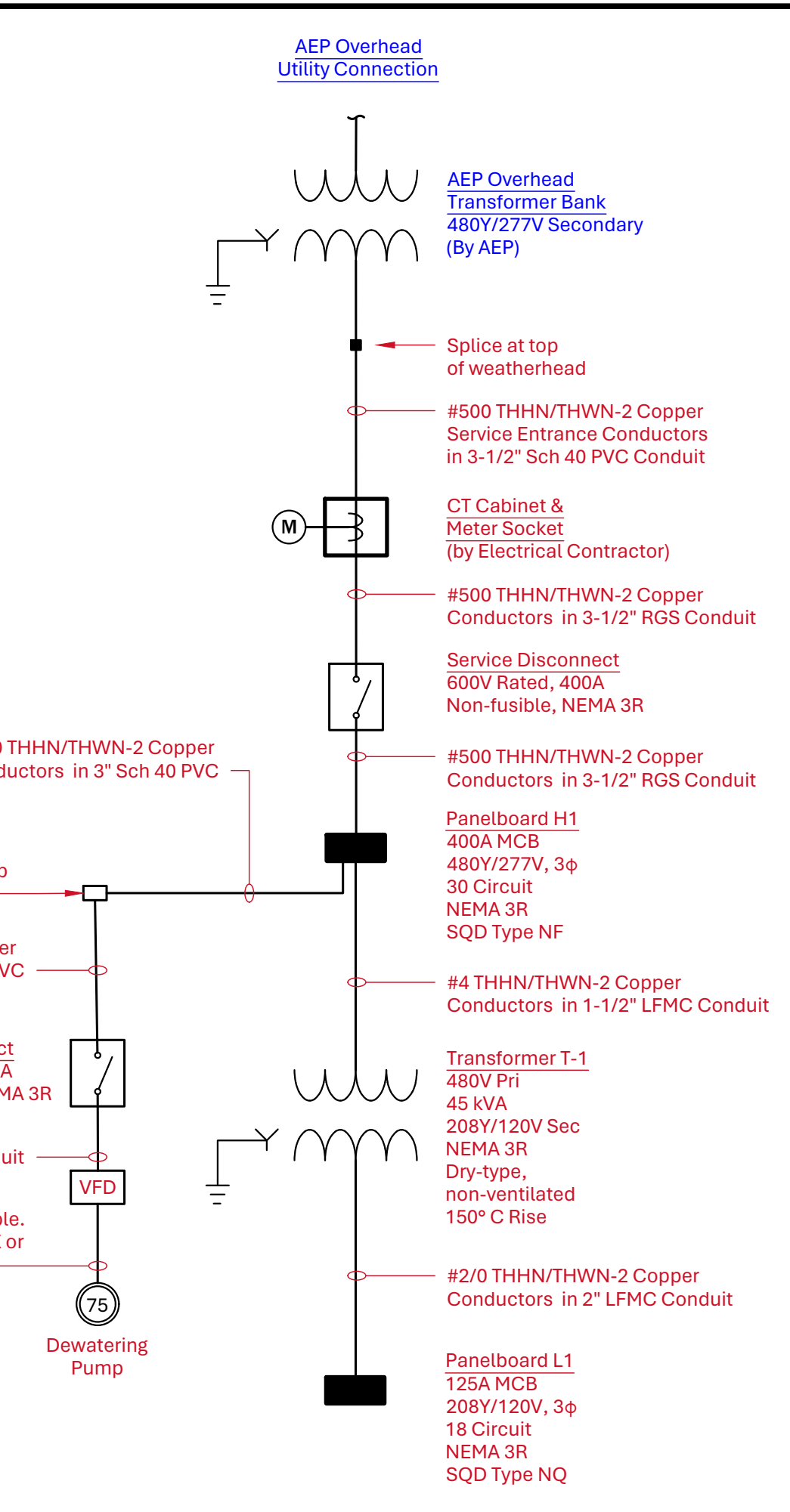
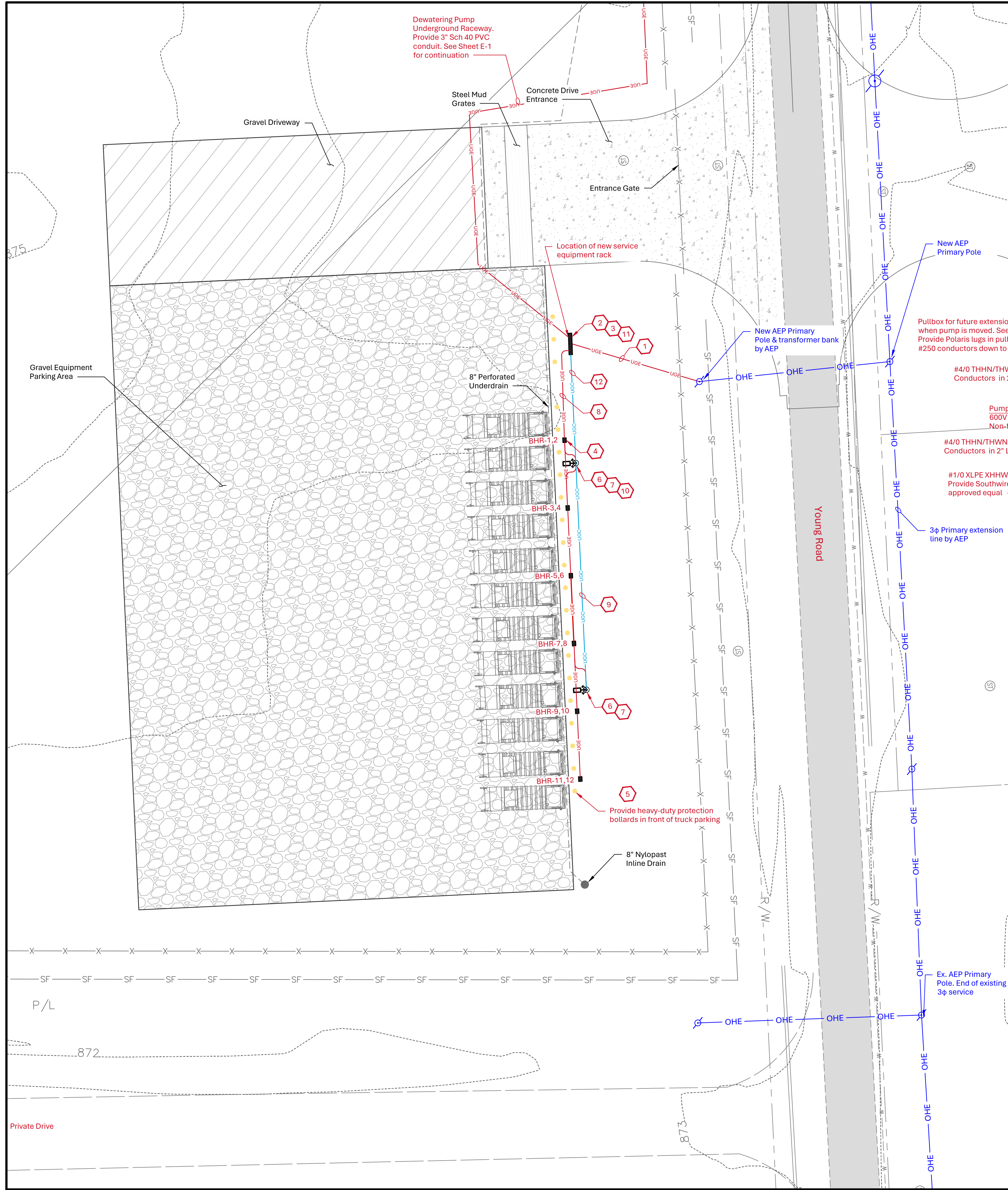

1 Single Line Diagram
Scale: Not Drawn to Scale

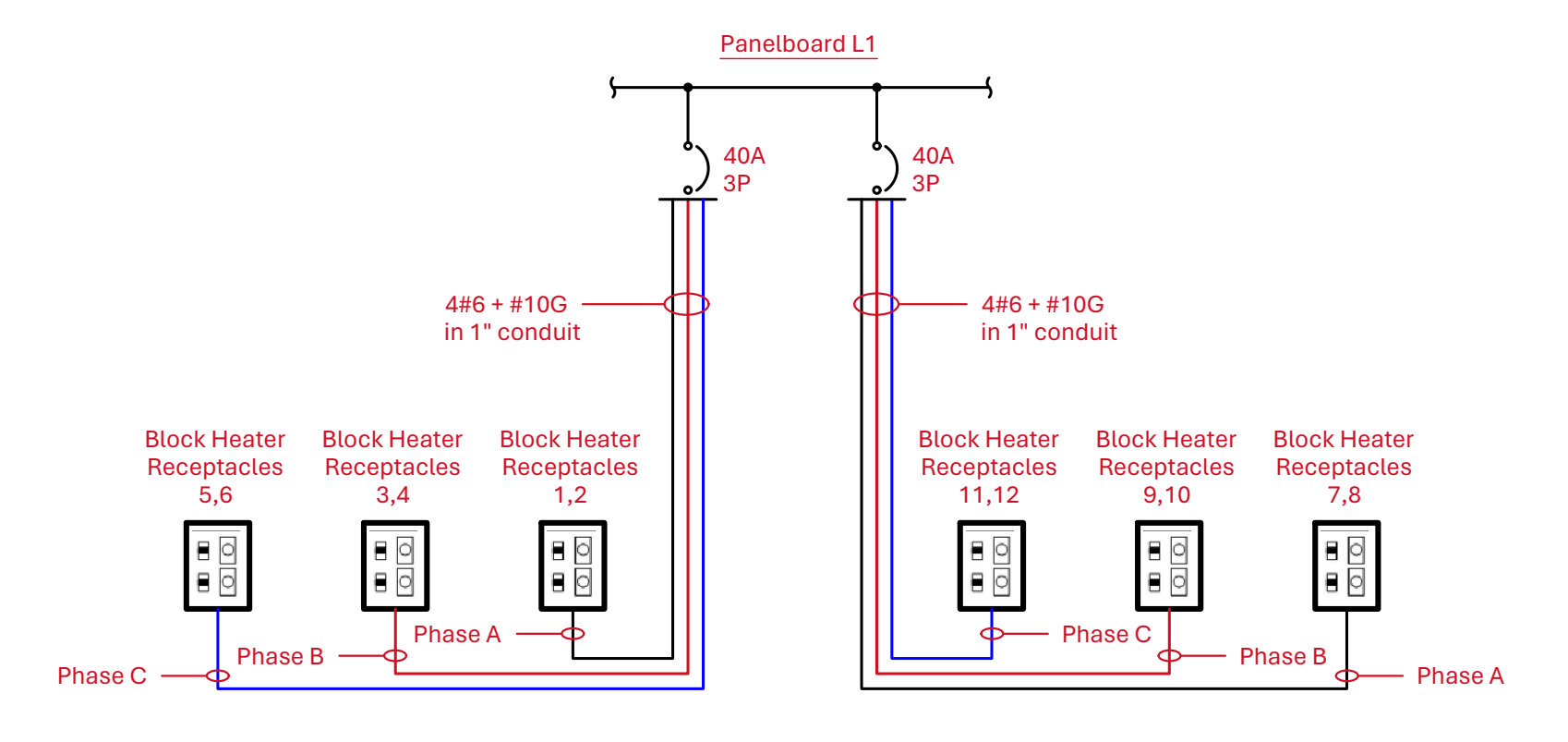

2 Block Heater Recept Wiring Diagram
Scale: Not Drawn to Scale

- CODED DESIGN NOTES:**
- Provide 3-1/2" underground Sch 40 PVC conduit from new power rack to new AEP service pole. Turn conduit up at pole and coordinate final connection with AEP.
 - Provide new equipment rack according to Detail 4 on Sheet E-4.
 - Following installation, obtain the available fault current at the service entrance from the Utility. Furnish and apply NFPA 70 compliant warning labels stating the available fault current and the date.
 - Provide block heater receptacle power pedestals, Model U011F010 on 6'-0" pedestal with integral loop-feed lugs to accommodate conductor sizes shown on wiring diagram. Provide from Midwest Electric Products, or approved equal. Pedestal shall have two 20A GFCI receptacles and two 20A circuit breakers. Pedestal shall be direct buried according to Manufacturer's written instructions. Typical of six (6) pedestals.
 - Provide heavy-duty concrete protection bollards, spaced every 8'-0" in front of truck parking area. Install bollards approximately 2'-0" off the gravel parking area. See Detail 2 on Sheet E-3. Typical of twenty-one (21) bollards.
 - Provide concrete base, pole and overhead utility light with integral dusk-to-dawn photocell. Provide light from LSI Industries, or approved equal, and mount at 25' AFS
LSI SMA LED 28L ACR 3 UNV DIM 40 IMSBT2 BRZ PM
 - Provide pole with internal raceways and bracket provisions for mounting security cameras.
 - Provide (2) 1" Sch 40 PVC conduits for block heater receptacle power pedestals and (1) 1" Sch 40 PVC conduit for site lights.
 - Provide (1) 1-1/2" Sch 40 PVC conduit with pull-string for future installation of security cameras. Conduit can share same trench as power conduits.
 - Provide AXIS Communications P3735-PLC Panoramic Camera on light pole bracket.
 - Provide AXIS Communications D8208-R Industrial PoE++ Switch inside the rack communications cabinet.
 - Provide (1) 1-1/2" Sch 40 PVC conduit with CAT6E ethernet cable for pole-mounted camera connection. Provide pull-string to allow installation of a second camera in the future.

- SINGLE LINE NOTES:**
- Provide copper conductors, THWN-2, 90° C for all branch circuits from Panelboards.
 - Provide 100% rated neutral. Neutral derating shall not be permitted.
 - Obtain the available fault current from AEP at the conclusion of construction. Furnish and apply NFPA 70 compliant warning labels stating the available fault current and the date.
 - Conductors for dewatering pump are oversized to account for voltage drop. A maximum distance of 1,015' was used for the temporary pump location and 1,225' for the future permanent pump location.

ISSUED FOR BID



Affinity Infrastructure, LLC
200 East Campus View Blvd
Suite 200
Columbus, OH 43235
AffinityInfrastructure.com

MARK	DATE	REVISION DESCRIPTION

MARK	DATE	REVISION DESCRIPTION

Client:
SWACO
FROM WASTE TO RESOURCES

Project Name:
West Young Rd Electrical Upgrades

Project Address:
6153 Young Rd.
Grove City, OH 43123

Project Number: 24007
Date: 2025.08.15
Engineer: RMJ
Designer: RMJ
Drafter: RMJ
Copyright: 2025

0 10' 20' 40'
SCALE: 1" = 20'

Sheet Name:
Enlarged Power Plan

Sheet Number:
E-2
Sheet 02 of 04

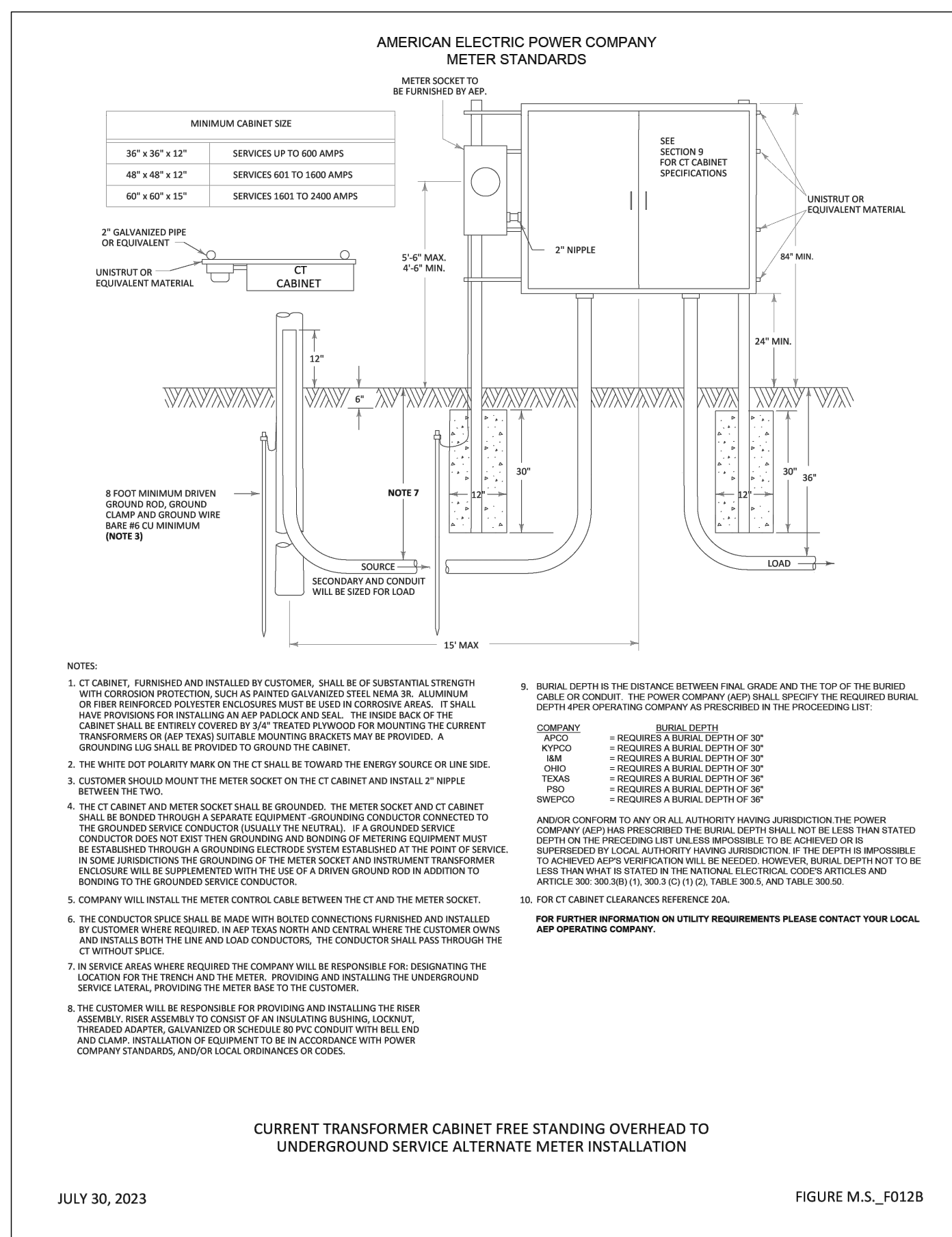

1 AEP Detail 1
SCALE: NONE

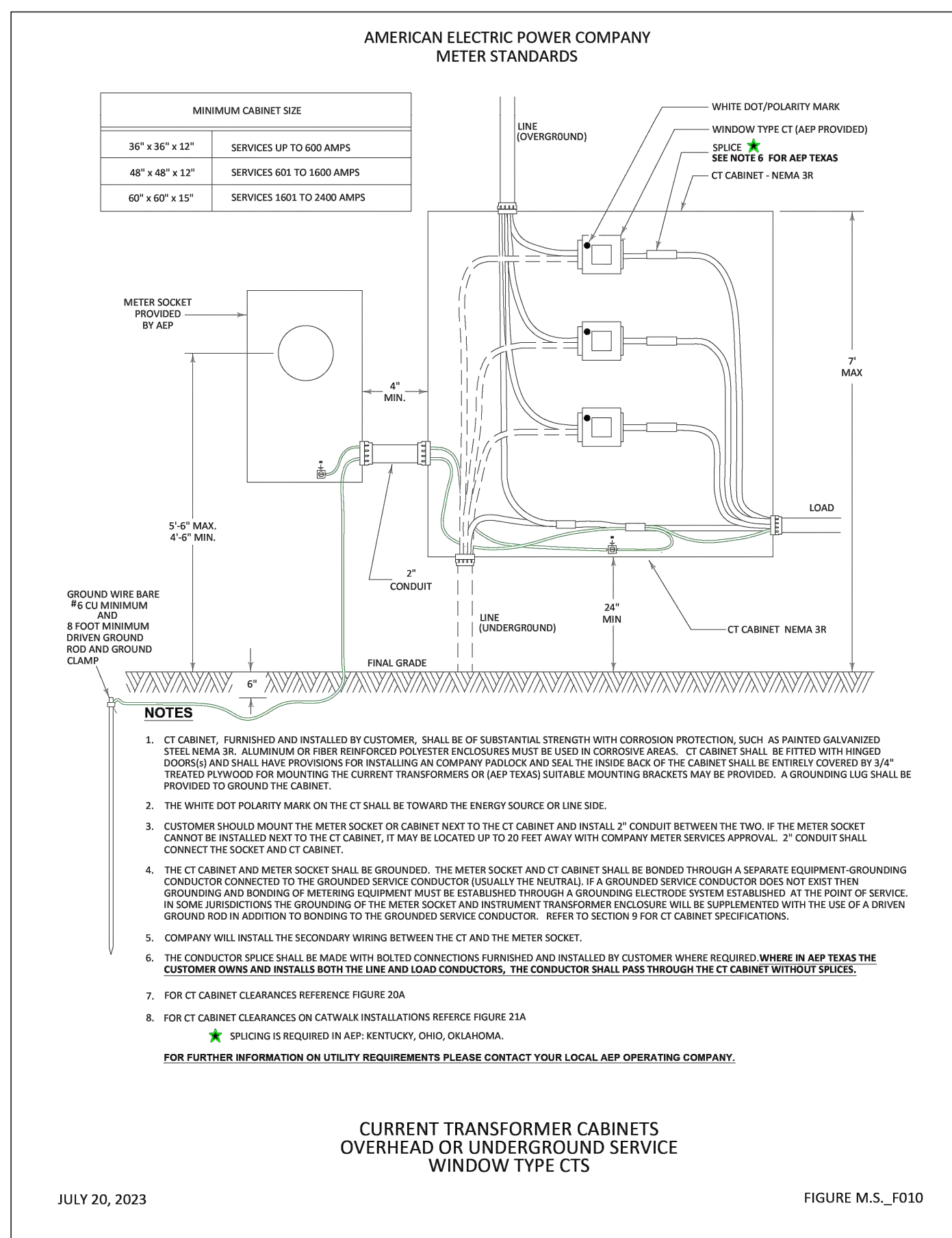

2 AEP Detail 2
SCALE: NONE

3 Free-standing Disconnect
SCALE: NONE

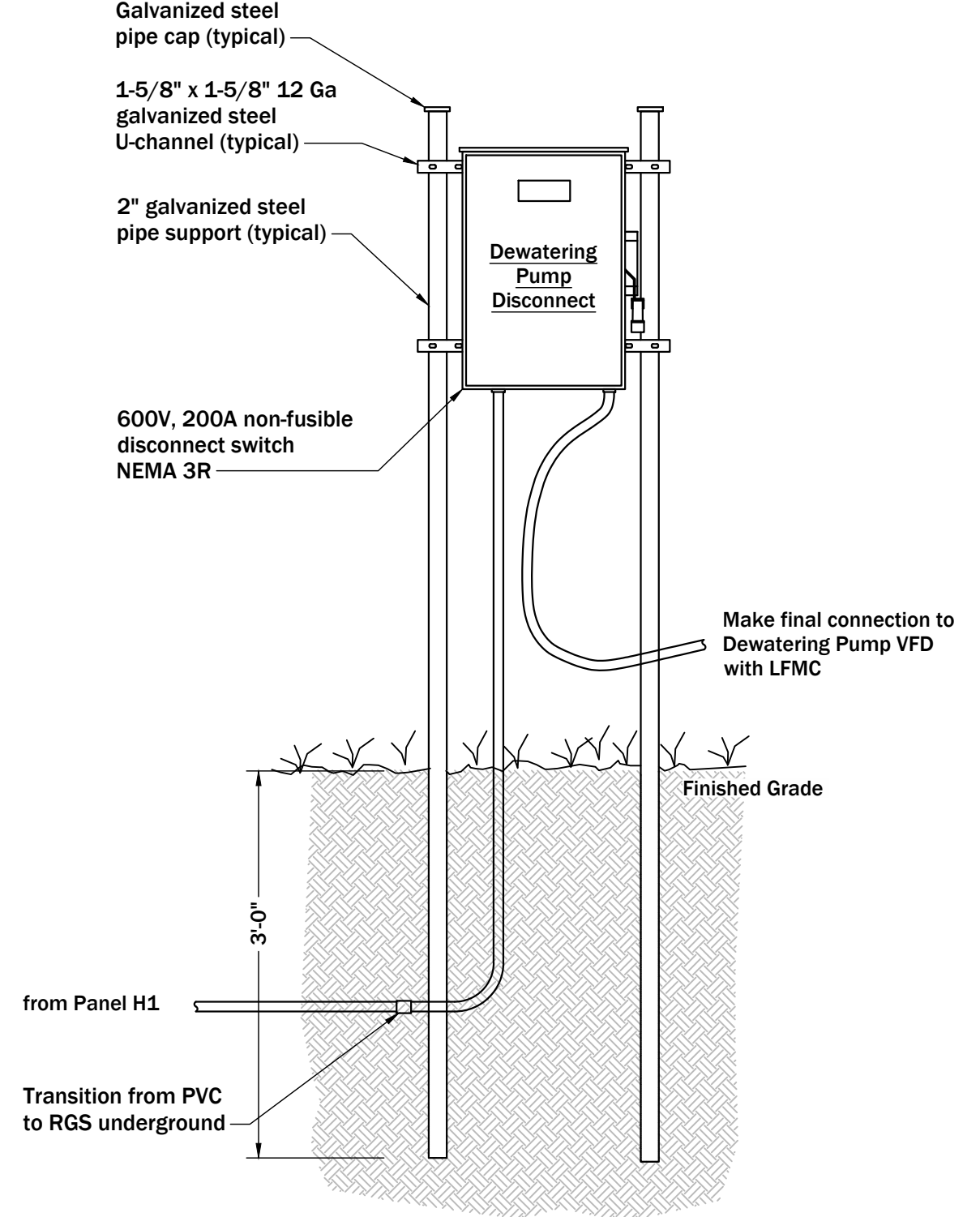

EQUIPMENT RACK NOTES:

- This equipment rack is a general representation of the expected equipment installation. The Electrical Contractor shall be responsible for coordinating the final dimensions based on specific equipment provided and Manufacturer's installation instructions.
- AEP Standard Details shall take precedence.
- All rack components, fittings, fasteners and support devices shall be galvanized steel.
- Install approved watertight fittings on all knockouts.
- All above ground conduit shall be RGS. Transition from PVC to rigid at the 90° elbow below grade.
- Provide concrete equipment pad for transformer base. Install transformer behind equipment rack.
- Provide phenolic plastic nameplates, 1/16 inch thick, engraved black lettering on white background for all rack components.
- Provide service grounding in accordance with AEP specifications and the latest edition of NEC, Article 250. Provide UL Listed ground clamps, ground rods and grounding conductor.
- Provide a 24" x 30" galvanized steel electrical box for Communication Equipment.

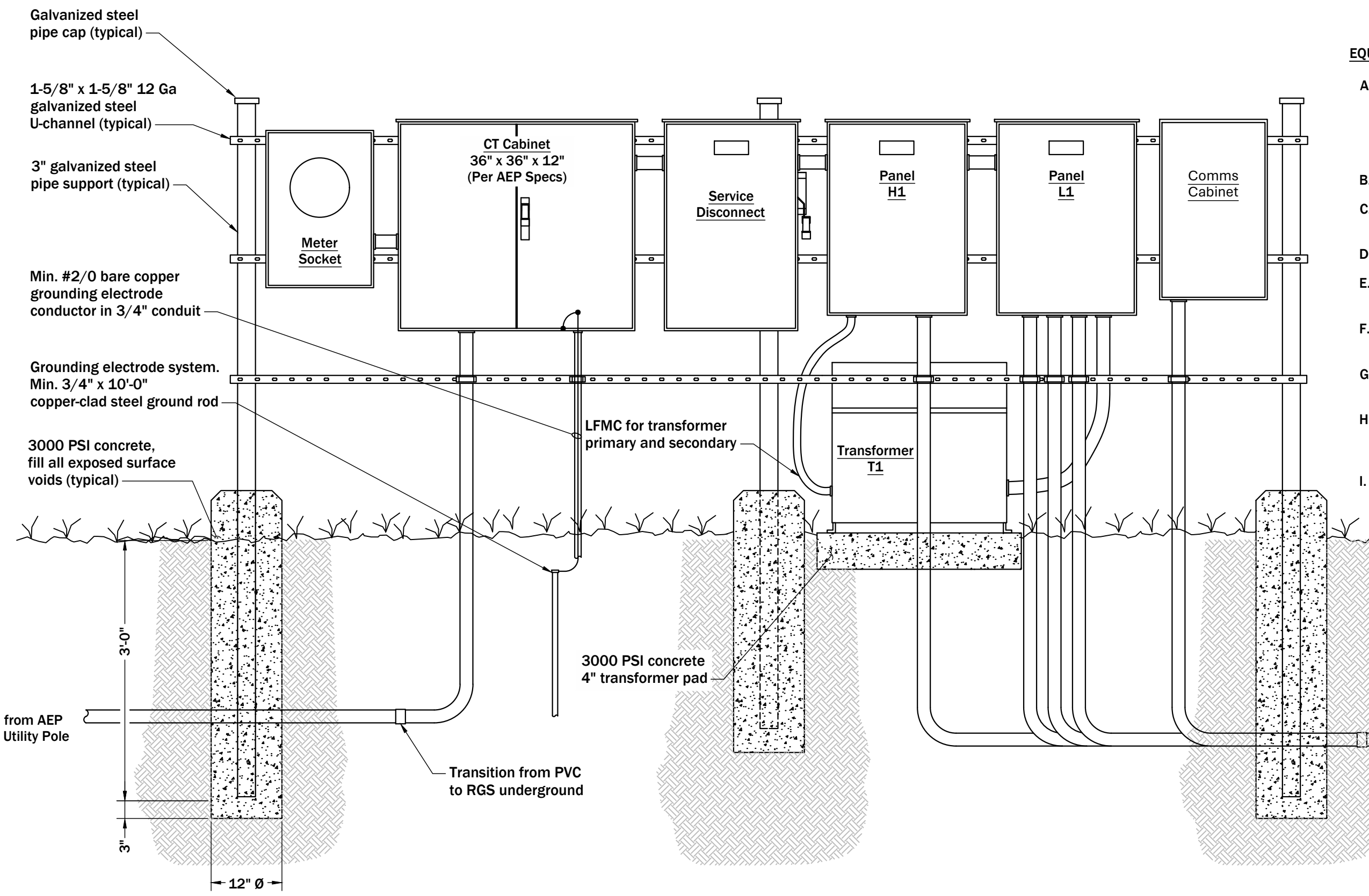

4 Electrical Equipment Rack
SCALE: NONE



Affinity Infrastructure, LLC
200 East Campus View Blvd
Suite 200
Columbus, OH 43235
AffinityInfrastructure.com

MARK	DATE	REVISION DESCRIPTION



Client: SWACO FROM WASTE TO RESOURCES

Project Name: West Young Rd Electrical Upgrades

Project Address: 6153 Young Rd. Grove City, OH 43123

Project Number: 24007
Date: 2025.08.15
Engineer: RMJ
Designer: RMJ
Drafter: RMJ
Copyright: 2025

Sheet Name: Electrical Details 2

Sheet Number: E-4
Sheet 04 of 04

ISSUED FOR BID

Exhibit G

009. Prevailing Wages

The following Prevailing Wage Rate pages are from the Ohio Department of Commerce. Please note that it is the responsibility of the Successful Bidder to comply with prevailing wages as directed by the Ohio Department of Commerce.

An Official State of Ohio site. [Here's how you know](#)

Prevailing Wage Rates - Skilled Crafts

Details

Union	Change#	Craft	Effective Date	Posted Date
Asbestos Local 50 Heat & Frost Insulators	LCN02-2025ib	Asbestos Worker	07/30/2025	07/30/2025

Wage Rates

		Fringe Benefit Payments						Irrevocable Fund		Total PWR	Overtime Rate
		H&W	Pension	App Tr.	Vac.	Annuity	Other	LECET (*)	MISC (*)		
Classification	BHR										
Asbestos Insulation Mechanic	\$40.56	\$9.55	\$9.60	\$0.55	\$0.00	\$4.75	\$0.00	\$0.00	\$0.00	\$65.01	\$85.29
Firestop Technician	\$40.56	\$9.55	\$9.60	\$0.55	\$0.00	\$4.75	\$0.00	\$0.00	\$0.00	\$65.01	\$85.29
Apprentice	Percent	BHR									
1st year	63.630000	\$25.81	\$9.55	\$4.52	\$0.50	\$0.00	\$0.50	\$0.00	\$0.00	\$40.88	\$53.78
2nd year	74.230000	\$30.11	\$9.55	\$4.52	\$0.50	\$0.00	\$0.85	\$0.00	\$0.00	\$45.53	\$60.59
3rd year	84.830000	\$34.41	\$9.55	\$6.76	\$0.50	\$0.00	\$1.25	\$0.00	\$0.00	\$52.47	\$69.67
4th year	90.130000	\$36.56	\$9.55	\$6.76	\$0.50	\$0.00	\$1.50	\$0.00	\$0.00	\$54.87	\$73.15

Special Calculation Note

Ratio

1 Journeymen to 1 Apprentice
 4 Journeymen to 1 Apprentice thereafter

Jurisdiction (* denotes special jurisdictional note)

Athens, Auglaize, Butler*, Champaign, Clark, Clinton, Crawford, Darke, Delaware, Fairfield, Fayette, Franklin, Greene, Guernsey, Hardin, Hocking, Knox, Licking, Logan, Madison, Marion, Miami, Montgomery, Morgan, Morrow, Muskingum, Noble, Perry, Pickaway, Preble, Ross, Shelby, Union, Vinton, Warren*

Special Jurisdictional Note

Butler County: Townships of Lemon and Madison.
Warren County: Township of Clear Creek, Franklin, Massie, Turtle Creek and Wayne

Details

Prevailing Wage Rate Skilled Crafts

Name of Union: Asbestos Local 50 Zone 1

Change # : LCN01-2024ibAsbLoc50Zone1

Craft : Asbestos Worker Effective Date : 03/06/2024 Last Posted : 03/06/2024

	BHR		Fringe Benefit Payments					Irrevocable Fund		Total PWR	Overtime Rate	
			H&W	Pension	App Tr.	Vac.	Annuity	Other	LECET (*)			MISC (*)
Classification												
Asbestos Insulation Mechanic	\$35.61		\$9.20	\$8.35	\$0.50	\$0.00	\$3.75	\$0.10	\$0.00	\$0.00	\$57.51	\$75.31
Firestop Technician	\$35.61		\$9.20	\$8.35	\$0.50	\$0.00	\$3.75	\$0.10	\$0.00	\$0.00	\$57.51	\$75.31
Apprentice	Percent											
1st year	54.14	\$19.28	\$8.96	\$0.00	\$0.44	\$0.00	\$0.50	\$0.10	\$0.00	\$0.00	\$29.28	\$38.92
2nd year	65.85	\$23.45	\$9.20	\$0.95	\$0.44	\$0.00	\$0.85	\$0.10	\$0.00	\$0.00	\$34.99	\$46.71
3rd year	76.72	\$27.32	\$9.20	\$2.38	\$0.44	\$0.00	\$1.25	\$0.10	\$0.00	\$0.00	\$40.69	\$54.35
4th year	84.04	\$29.93	\$9.20	\$2.38	\$0.44	\$0.00	\$1.50	\$0.10	\$0.00	\$0.00	\$43.55	\$58.51

Special Calculation Note : *other is Labor Mgt Training Fund

Ratio :

1 Journeymen to 1 Apprentice
4 Journeymen to 1 Apprentice thereafter

Jurisdiction (* denotes special jurisdictional note) :

ATHENS, AUGLAIZE, BUTLER*, CLINTON, CRAWFORD, DELAWARE, FAIRFIELD, FAYETTE, FRANKLIN, GUERNSEY, HARDIN, HOCKING, KNOX, LICKING, LOGAN, MADISON, MARION, MORGAN, MORROW, MUSKINGUM, NOBLE, PERRY, PICKAWAY, ROSS, SHELBY, UNION, VINTON, WARREN*

Special Jurisdictional Note : Township of Butler County-Townships of Lemon and Madison. Warren County-Township of Clear Creek, Franklin, Massie, Turtle Creek and Wayne

Details :

Prevailing Wage Rate Skilled Crafts

Name of Union: Asbestos Local 207

Type of Rate: Commercial

Change #:
LCN01-2025ib

Craft:
Asbestos Worker

Effective Date:
8/6/2025

Effective Date:
8/6/2025

	BHR		Fringe Benefit Payments						Irrevocable Fund		Total PWR	Overtime Rate
			H&W	Pension	App Tr.	Vac.	Annuity	Other	LECET (*)	MISC (*)		
Classification												
Asbestos Abatement	\$32.50		\$10.95	\$7.25	\$0.75	\$3.75	\$0.00	\$0.05	\$0.00	\$0.00	\$55.25	\$71.50
Apprentice	BHR	Percent										
Trainee	\$22.00	\$67.69	\$10.95	\$1.90	\$0.75	\$1.00	\$0.00	\$0.05	\$0.00	\$0.00	\$36.65	\$47.65

(*)Special Calculation Note :

Other: Drug Testing

Ratio :

3 Journeymen to 1 Trainee

Jurisdiction (* denotes special jurisdictional note) :

Adams, Ashland, Ashtabula*, Athens, Auglaize, Brown, Butler*, Carroll, Champaign, Clark, Clermont, Clinton, Columbiana, Coshocton, Crawford, Cuyahoga, Darke, Delaware, Erie*, Fairfield, Fayette, Franklin, Geauga, Greene, Guernsey, Hamilton, Hardin, Harrison, Highland, Hocking, Holmes, Huron, Knox, Lake, Licking, Logan, Lorain, Madison, Mahoning, Marion, Medina, Miami, Montgomery, Morgan, Morrow, Muskingum, Noble, Perry, Pickaway, Portage, Preble, Richland, Ross, Shelby, Stark, Summit, Trumbull, Tuscarawas, Union, Vinton, Warren*, Wayne

Special Jurisdictional Note :

Ashtabula County: (post offices & townships of Ashtabula, Austinburg, Geneva, Harperfield, Jefferson, Plymouth & Saybrook) (townships of Andover, Cherry Valley, Colbrook, Canneaut, Denmark, Dorset, East Orwell, Hartsgrove, Kingville, Lenox, Monroe, Morgan, New Lyme, North Kingsville, Orwell, Pierpoint, Richmond Rock Creek, Rome, Sheffield, Trumbull, Wayne, Williamsfield & Windsor)

Butler County: (townships of Fairfield, Hanover, Liberty, Milford, Morgan, Oxford, Ripley, Ross, St. Clair, Union & Wayne) (Lemon & Madison)

Erie County: (post offices & townships of Berlin, Berlin Heights, Birmingham, Florence, Huron, Milan, Shinrock & Vermilion)

Warren County: (townships of: Deerfield, Hamilton, Harlan, Salem, Union & Washington) (Clear Creek, Franklin, Mossie, Turtle Creek & Wayne)

Details :

An Abatement Journeyman is anyone who has more than 600 hours in the Asbestos Abatement field.

Asbestos & lead paint abatement including, but not limited to the removal or encapsulation of asbestos & lead paint, all work in conjunction with the preparation of the removal of same & all work in conjunction with the clean up after said removal. The removal of all insulation materials, whether they contain asbestos or not, from mechanical systems (pipes, boilers, ducts, flues, breaching, etc.) is recognized as being the exclusive work of the Asbestos Abatement Workers.

On all mechanical systems (pipes, boilers, ducts, flues, breaching, etc.) that are going to be demolished, the removal of all insulating materials whether they contain asbestos or not shall be the exclusive work of the Laborers.

Prevailing Wage Rate Skilled Crafts

Name of Union: **Boilermaker Local 105**

Change # : LCN02-2013fbLoc 105

Craft : Boilermaker Effective Date : 10/01/2013 Last Posted : 09/25/2013

	BHR		Fringe Benefit Payments					Irrevocable Fund		Total PWR	Overtime Rate	
			H&W	Pension	App Tr.	Vac.	Annuity	Other	LECET (*)			MISC (*)
Classification												
Boilermaker	\$35.26		\$7.07	\$13.28	\$0.89	\$0.00	\$3.00	\$0.55	\$0.00	\$0.00	\$60.05	\$77.68
Apprentice	Percent											
1st 6 months	70.03	\$24.69	\$7.07	\$11.30	\$0.89	\$0.00	\$2.10	\$0.55	\$0.00	\$0.00	\$46.60	\$58.95
2nd 6 months	75.02	\$26.45	\$7.07	\$11.30	\$0.89	\$0.00	\$2.25	\$0.55	\$0.00	\$0.00	\$48.51	\$61.74
3rd 6 months	80.00	\$28.21	\$7.07	\$11.30	\$0.89	\$0.00	\$2.40	\$0.55	\$0.00	\$0.00	\$50.42	\$64.52
4th 6 months	85.02	\$29.98	\$7.07	\$11.30	\$0.89	\$0.00	\$2.55	\$0.55	\$0.00	\$0.00	\$52.34	\$67.33
5th 6 months	87.52	\$30.86	\$7.07	\$13.28	\$0.89	\$0.00	\$2.63	\$0.55	\$0.00	\$0.00	\$55.28	\$70.71
6th 6 months	90.03	\$31.74	\$7.07	\$13.28	\$0.89	\$0.00	\$2.70	\$0.55	\$0.00	\$0.00	\$56.23	\$72.11
7th 6 months	92.50	\$32.62	\$7.07	\$13.28	\$0.89	\$0.00	\$2.78	\$0.55	\$0.00	\$0.00	\$57.19	\$73.49
8th 6 months	95.00	\$33.50	\$7.07	\$13.28	\$0.89	\$0.00	\$2.85	\$0.55	\$0.00	\$0.00	\$58.14	\$74.89

Special Calculation Note : Other is Supplemental Health and Welfare

Ratio :

5 Journeymen to 1 Apprentice

Jurisdiction (* denotes special jurisdictional note) :

ADAMS, ATHENS, BROWN, BUTLER, CHAMPAIGN, CLARK, CLERMONT, CLINTON, FAIRFIELD, FAYETTE, FRANKLIN, GALLIA, GREENE, GUERNSEY, HAMILTON, HIGHLAND, HOCKING, JACKSON, LAWRENCE, LICKING, MADISON, MEIGS, MIAMI, MONTGOMERY, MORGAN, MUSKINGUM, NOBLE, PERRY, PICKAWAY, PIKE, PREBLE, ROSS, SCIOTO, VINTON, WARREN

Special Jurisdictional Note :

Details :

Prevailing Wage Rate Skilled Crafts

Name of Union: **Bricklayer Local 23 (Columbus Tile Finisher)**

Change # : LCN01-2025ibLoc23CbusTileFin

Craft : Bricklayer Effective Date : 06/01/2025 Last Posted : 05/28/2025

	BHR		Fringe Benefit Payments					Irrevocable Fund		Total PWR	Overtime Rate	
			H&W	Pension	App Tr.	Vac.	Annuity	Other	LECET (*)			MISC (*)
Classification												
Bricklayer Tile Marble Finisher	\$31.75		\$8.72	\$3.24	\$0.55	\$0.00	\$0.50	\$0.00	\$0.00	\$0.00	\$44.76	\$60.64
Terrazzo Finisher	\$32.00		\$8.72	\$3.24	\$0.55	\$0.00	\$0.50	\$0.00	\$0.00	\$0.00	\$45.01	\$61.01
Floor Grinder	\$32.25		\$8.72	\$3.24	\$0.55	\$0.00	\$0.50	\$0.00	\$0.00	\$0.00	\$45.26	\$61.39
Base Grinder	\$32.50		\$8.72	\$3.24	\$0.55	\$0.00	\$0.50	\$0.00	\$0.00	\$0.00	\$45.51	\$61.76
Apprentice Percent												
1st Year	70.00	\$22.22	\$8.72	\$3.24	\$0.55	\$0.00	\$0.50	\$0.00	\$0.00	\$0.00	\$35.24	\$46.35
2nd Year	80.00	\$25.40	\$8.72	\$3.24	\$0.55	\$0.00	\$0.50	\$0.00	\$0.00	\$0.00	\$38.41	\$51.11
3rd Year	90.00	\$28.57	\$8.72	\$3.24	\$0.55	\$0.00	\$0.50	\$0.00	\$0.00	\$0.00	\$41.59	\$55.87
Apprentice Improver	50.00	\$15.88	\$0.00	\$0.00	\$0.00	\$0.00	\$0.00	\$0.00	\$0.00	\$0.00	\$15.88	\$23.81

Special Calculation Note :

Ratio :

- 1-2 Journeymen to 1 Apprentice
- 3-5 Journeymen to 2 Apprentice
- Crews larger than 5: 4 Journeymen to 1 Apprentice

Jurisdiction (* denotes special jurisdictional note) :

ATHENS, COSHOCTON, DELAWARE, FAIRFIELD, FAYETTE, FRANKLIN, GUERNSEY, HOCKING, JACKSON, KNOX, LICKING, MADISON, MEIGS, MORGAN, MUSKINGUM, NOBLE, PERRY, PICKAWAY, PIKE, ROSS, UNION, VINTON, WASHINGTON

Special Jurisdictional Note :

Details :

Prevailing Wage Rate Skilled Crafts

Name of Union: Bricklayer Local 23 (Columbus Tile Setter)

Change # : LCN01-2025ibLoc23CbusTileSet

Craft : Bricklayer Effective Date : 06/01/2025 Last Posted : 05/28/2025

	BHR		Fringe Benefit Payments					Irrevocable Fund		Total PWR	Overtime Rate	
			H&W	Pension	App Tr.	Vac.	Annuity	Other	LECET (*)			MISC (*)
Classification												
Bricklayer Tile Setter	\$33.89		\$9.47	\$7.40	\$0.68	\$0.00	\$1.25	\$0.00	\$0.00	\$0.00	\$52.69	\$69.64
Marble Mason	\$33.89		\$9.47	\$7.40	\$0.68	\$0.00	\$1.25	\$0.00	\$0.00	\$0.00	\$52.69	\$69.64
Terrazzo Worker	\$34.14		\$9.47	\$7.40	\$0.68	\$0.00	\$1.25	\$0.00	\$0.00	\$0.00	\$52.94	\$70.01
Terrazzo Worker, Installation	\$34.14		\$9.47	\$7.40	\$0.68	\$0.00	\$1.25	\$0.00	\$0.00	\$0.00	\$52.94	\$70.01
Apprentice	Percent											
1st Year	70.00	\$23.72	\$9.47	\$7.40	\$0.68	\$0.00	\$1.25	\$0.00	\$0.00	\$0.00	\$42.52	\$54.38
2nd Year	80.00	\$27.11	\$9.47	\$7.40	\$0.68	\$0.00	\$1.25	\$0.00	\$0.00	\$0.00	\$45.91	\$59.47
3rd Year	90.00	\$30.50	\$9.47	\$7.40	\$0.68	\$0.00	\$1.25	\$0.00	\$0.00	\$0.00	\$49.30	\$64.55
4th Year	95.00	\$32.20	\$9.47	\$7.40	\$0.68	\$0.00	\$1.25	\$0.00	\$0.00	\$0.00	\$51.00	\$67.09

Special Calculation Note :

Ratio :

- 1 - 3 Journeyman to 1 Apprentice
- 4 - 8 Journeyman to 2 Apprentice
- 9 - 13 Journeyman to 3 Apprentice
- 14 - 18 Journeyman to 4 Apprentice

Jurisdiction (* denotes special jurisdictional note) :

ATHENS, COSHOCTON, DELAWARE, FAIRFIELD, FAYETTE, FRANKLIN, GUERNSEY, HOCKING, JACKSON, KNOX, LICKING, MADISON, MEIGS, MORGAN, MUSKINGUM, NOBLE, PERRY, PICKAWAY, PIKE, ROSS, UNION, VINTON, WASHINGTON

Special Jurisdictional Note : Noble County: (Townships of Beaver, Buffalo, Seneca & Wayne)

Details :

Prevailing Wage Rate Skilled Crafts

Name of Union: **Bricklayer Local 23 (Columbus)**

Change # : LCN01-2025ibLoc23Cbus

Craft : Bricklayer Effective Date : 06/01/2025 Last Posted : 05/28/2025

	BHR		Fringe Benefit Payments					Irrevocable Fund		Total PWR	Overtime Rate	
			H&W	Pension	App Tr.	Vac.	Annuity	Other	LECET (*)			MISC (*)
Classification												
Bricklayer	\$37.35		\$10.48	\$9.04	\$0.74	\$0.00	\$1.25	\$0.00	\$0.00	\$0.00	\$58.86	\$77.54
Lay Out Man	\$37.85		\$10.48	\$9.04	\$0.74	\$0.00	\$1.25	\$0.00	\$0.00	\$0.00	\$59.36	\$78.29
Saw Man	\$37.85		\$10.48	\$9.04	\$0.74	\$0.00	\$1.25	\$0.00	\$0.00	\$0.00	\$59.36	\$78.29
Stone & Cement Mason	\$37.35		\$10.48	\$9.04	\$0.74	\$0.00	\$1.25	\$0.00	\$0.00	\$0.00	\$58.86	\$77.54
Pointer Caulker Cleaner Block Stone	\$37.35		\$10.48	\$9.04	\$0.74	\$0.00	\$1.25	\$0.00	\$0.00	\$0.00	\$58.86	\$77.54
Plaster	\$37.35		\$10.48	\$9.04	\$0.74	\$0.00	\$1.25	\$0.00	\$0.00	\$0.00	\$58.86	\$77.54
Swing Stage (Ground Floors thru 23 Floors)	\$38.35		\$10.48	\$9.04	\$0.74	\$0.00	\$1.25	\$0.00	\$0.00	\$0.00	\$59.86	\$79.04
Swing Stage (24th Floors and Above)	\$39.35		\$10.48	\$9.04	\$0.74	\$0.00	\$1.25	\$0.00	\$0.00	\$0.00	\$60.86	\$80.54
Apprentice Bricklayers & Stone & Pointer Caulker Cleaner	Percent											
1st Year	70.00	\$26.14	\$10.48	\$9.04	\$0.74	\$0.00	\$1.25	\$0.00	\$0.00	\$0.00	\$47.66	\$60.73
2nd Year	80.00	\$29.88	\$10.48	\$9.04	\$0.74	\$0.00	\$1.25	\$0.00	\$0.00	\$0.00	\$51.39	\$66.33
3rd Year	90.00	\$33.62	\$10.48	\$9.04	\$0.74	\$0.00	\$1.25	\$0.00	\$0.00	\$0.00	\$55.13	\$71.93
4th Year	95.00	\$35.48	\$10.48	\$9.04	\$0.74	\$0.00	\$1.25	\$0.00	\$0.00	\$0.00	\$56.99	\$74.73
MASON TRAINEES												
1-90 Days	50.02	\$18.68	\$0.00	\$0.00	\$0.00	\$0.00	\$0.00	\$0.00	\$0.00	\$0.00	\$18.68	\$28.02
90-365 Days	50.02	\$18.68	\$10.48	\$0.00	\$0.00	\$0.00	\$0.00	\$0.00	\$0.00	\$0.00	\$29.16	\$38.50
2nd Year	55.00	\$20.54	\$10.48	\$0.00	\$0.00	\$0.00	\$0.00	\$0.00	\$0.00	\$0.00	\$31.02	\$41.29

Special Calculation Note : No special calculations for this skilled craft wage rate are required at this time.

Ratio :

REQUIRED RATIO

- 1-2 Journeyman to 1 Apprentice
- 3- 6 Journeyman to 2 Apprentice
- 7-10 Journeyman to 3 Apprentice
- 1-15 Journeyman to 4 Apprentice

MASON TRAINEE REQUIRED RATIO

Jurisdiction (* denotes special jurisdictional note) :

DELAWARE, FRANKLIN, MADISON, PICKAWAY, UNION

- 1 Apprentice permits 1 Mason Trainee
- 2 Apprentice permits 1 Mason Trainee
- 3 Apprentice permits 2 Mason Trainee
- 4 Apprentice permits 2 Mason Trainee

Special Jurisdictional Note :

Details :

MASON TRAINEE: duties shall be to work in all aspects of Masonry construction taking direction from the employer and the Journeyman Bricklayer & Stone Mason's working on the job.

MASON TRAINEE may work on job site only when a registered apprentice is on job and the ratios in above table will be strictly enforced.

Above Journeyman Rate:

Brick Power Saw Pay \$.50

Designated layout person \$.50

Swingstage Work \$1.00 at start, and additional \$2.00 at 24th floor

Prevailing Wage Rate Skilled Crafts

Name of Union: Bricklayer Local 23 Heavy Hwy (A)

Change # : LCN01-2024ibLoc23HevHwyA

Craft : Bricklayer Effective Date : 06/05/2024 Last Posted : 06/05/2024

	BHR		Fringe Benefit Payments					Irrevocable Fund		Total PWR	Overtime Rate	
			H&W	Pension	App Tr.	Vac.	Annuity	Other	LECET (*)			MISC (*)
Classification												
Cement Mason Bricklayer Sewer Water Works A	\$33.39		\$10.00	\$9.53	\$0.53	\$0.00	\$0.00	\$0.00	\$0.00	\$0.00	\$53.45	\$70.14
Apprentice	Percent											
1st year	70.00	\$23.37	\$10.00	\$9.53	\$0.53	\$0.00	\$0.00	\$0.00	\$0.00	\$0.00	\$43.43	\$55.12
2nd year	80.00	\$26.71	\$10.00	\$9.53	\$0.53	\$0.00	\$0.00	\$0.00	\$0.00	\$0.00	\$46.77	\$60.13
3rd year	90.00	\$30.05	\$10.00	\$9.53	\$0.53	\$0.00	\$0.00	\$0.00	\$0.00	\$0.00	\$50.11	\$65.14

Special Calculation Note : NOT FOR BUILDING CONSTRUCTION.

Ratio :

- 3 Journeymen to 1 Apprentice
- 6 Journeymen to 2 Apprentice
- 9 Journeymen to 3 Apprentice
- 12 Journeymen to 4 Apprentice
- 15 Journeymen to 5 Apprentice

Jurisdiction (* denotes special jurisdictional note) :

- ADAMS, ALLEN, ASHLAND, ASHTABULA, ATHENS, AUGLAIZE, BELMONT, BROWN, BUTLER, CARROLL, CHAMPAIGN, CLARK, CLERMONT, CLINTON, COLUMBIANA, COSHOCTON, CRAWFORD, CUYAHOGA, DARKE, DEFIANCE, DELAWARE, ERIE, FAIRFIELD, FAYETTE, FRANKLIN, FULTON, GALLIA, GEAUGA, GREENE, GUERNSEY, HAMILTON, HANCOCK, HARDIN, HARRISON, HENRY, HIGHLAND, HOCKING, HOLMES, HURON, JACKSON, JEFFERSON, KNOX, LAKE, LAWRENCE, LICKING, LOGAN, LORAIN, LUCAS, MADISON, MAHONING, MARION, MEDINA, MEIGS, MERCER, MIAMI, MONROE, MONTGOMERY, MORGAN, MORROW, MUSKINGUM, NOBLE, OTTAWA, PAULDING, PERRY, PICKAWAY, PIKE, PORTAGE, PREBLE, PUTNAM, RICHLAND, ROSS, SANDUSKY, SCIOTO, SENECA, SHELBY, STARK, SUMMIT, TRUMBULL, TUSCARAWAS, UNION, VAN WERT, VINTON, WARREN, WASHINGTON, WAYNE

Special Jurisdictional Note :

Details :

(A) Highway Construction, Sewer, Waterworks And Utility Construction, Industrial & Building Site Heavy Construction, Airport Construction Or Railroad Construction Work.

(B) Power Plant, Tunnels, Amusement Park, Athletic Stadium Site Work ,Pollution Control,Sewer Plant, Waste Plant, & Water Treatment Facilities, Construction.

Prevailing Wage Rate Skilled Crafts

Name of Union: Bricklayer Local 23 Heavy Hwy (B)

Change # : LCN01-2024ibLoc23HevHwyB

Craft : Bricklayer Effective Date : 06/05/2024 Last Posted : 06/05/2024

	BHR		Fringe Benefit Payments					Irrevocable Fund		Total PWR	Overtime Rate	
			H&W	Pension	App Tr.	Vac.	Annuity	Other	LECET (*)			MISC (*)
Classification												
Cement Mason Bricklayer Power Plants Tunnels Amusement Parks B	\$34.39		\$10.00	\$9.52	\$0.54	\$0.00	\$0.00	\$0.00	\$0.00	\$0.00	\$54.45	\$71.65
Apprentice	Percent											
1st year	70.00	\$24.07	\$10.00	\$9.52	\$0.54	\$0.00	\$0.00	\$0.00	\$0.00	\$0.00	\$44.13	\$56.17
2nd year	80.00	\$27.51	\$10.00	\$9.52	\$0.54	\$0.00	\$0.00	\$0.00	\$0.00	\$0.00	\$47.57	\$61.33
3rd year	90.00	\$30.95	\$10.00	\$9.52	\$0.54	\$0.00	\$0.00	\$0.00	\$0.00	\$0.00	\$51.01	\$66.49

Special Calculation Note : NOT FOR BUILDING CONSTRUCTION.

Ratio :

- 3 Journeymen to 1 Apprentice
- 6 Journeymen to 2 Apprentice
- 9 Journeymen to 2 Apprentice
- 12 Journeymen to 4 Apprentice
- 15 Journeymen to 5 Apprentice

Jurisdiction (* denotes special jurisdictional note) :

- ADAMS, ALLEN, ASHLAND, ASHTABULA, ATHENS, AUGLAIZE, BELMONT, BROWN, BUTLER, CARROLL, CHAMPAIGN, CLARK, CLERMONT, CLINTON, COLUMBIANA, COSHOCTON, CRAWFORD, CUYAHOGA, DARKE, DEFIANCE, DELAWARE, ERIE, FAIRFIELD, FAYETTE, FRANKLIN, FULTON, GALLIA, GEAUGA, GREENE, GUERNSEY, HAMILTON, HANCOCK, HARDIN, HARRISON, HENRY, HIGHLAND, HOCKING, HOLMES, HURON, JACKSON, JEFFERSON, KNOX, LAKE, LAWRENCE, LICKING, LOGAN, LORAIN, LUCAS, MADISON, MAHONING, MARION, MEDINA, MEIGS, MERCER, MIAMI, MONROE, MONTGOMERY, MORGAN, MORROW, MUSKINGUM, NOBLE, OTTAWA, PAULDING, PERRY, PICKAWAY, PIKE, PORTAGE, PREBLE, PUTNAM, RICHLAND, ROSS, SANDUSKY, SCIOTO, SENECA, SHELBY, STARK, SUMMIT,

TRUMBULL, TUSCARAWAS, UNION, VAN WERT,
VINTON, WARREN, WASHINGTON, WAYNE

Special Jurisdictional Note :

Details :

(A) Highway Construction, Sewer, Waterworks And Utility Construction, Industrial & Building Site Heavy Construction, Airport Construction Or Railroad Construction Work.

(B) Power Plant, Tunnels, Amusement Park, Athletic Stadium Site Work ,Pollution Control,Sewer Plant, Waste Plant, & Water Treatment Facilities, Construction.

Prevailing Wage Rate Skilled Crafts

Name of Union: Carpenter & Pile Driver Local 200

Change # : LCN01-2025ibLoc200

Craft : Carpenter Effective Date : 05/07/2025 Last Posted : 05/07/2025

	BHR		Fringe Benefit Payments					Irrevocable Fund		Total PWR	Overtime Rate	
			H&W	Pension	App Tr.	Vac.	Annuity	Other	LECET (*)			MISC (*)
Classification												
Carpenter	\$35.94		\$8.85	\$10.78	\$0.70	\$0.00	\$3.26	\$0.16	\$0.00	\$0.00	\$59.69	\$77.66
Pile Driver	\$35.69		\$8.85	\$10.78	\$0.70	\$0.00	\$3.26	\$0.16	\$0.00	\$0.00	\$59.44	\$77.28
Apprentice paid at % of their rate above												
	Percent											
1st 6 months	70.00	\$25.16	\$8.85	\$2.00	\$0.70	\$0.00	\$3.26	\$0.16	\$0.00	\$0.00	\$40.13	\$52.71
2nd 6 months	70.00	\$25.16	\$8.85	\$2.00	\$0.70	\$0.00	\$3.26	\$0.16	\$0.00	\$0.00	\$40.13	\$52.71
3rd 6 months	80.00	\$28.75	\$8.85	\$8.62	\$0.70	\$0.00	\$3.26	\$0.16	\$0.00	\$0.00	\$50.34	\$64.72
4th 6 months	80.00	\$28.75	\$8.85	\$8.62	\$0.70	\$0.00	\$3.26	\$0.16	\$0.00	\$0.00	\$50.34	\$64.72
5th 6 months	90.00	\$32.35	\$8.85	\$9.70	\$0.70	\$0.00	\$3.26	\$0.16	\$0.00	\$0.00	\$55.02	\$71.19
6th 6 months	90.00	\$32.35	\$8.85	\$9.70	\$0.70	\$0.00	\$3.26	\$0.16	\$0.00	\$0.00	\$55.02	\$71.19
7th 6 months	95.00	\$34.14	\$8.85	\$10.24	\$0.70	\$0.00	\$3.26	\$0.16	\$0.00	\$0.00	\$57.35	\$74.42
8th 6 months	95.00	\$34.14	\$8.85	\$10.24	\$0.70	\$0.00	\$3.26	\$0.16	\$0.00	\$0.00	\$57.35	\$74.42

Special Calculation Note : Other is UBC National Fund.

Ratio :

1 Journeyman to 1 Apprentice
Thereafter
2 Journeyman to 1 Apprentice

Jurisdiction (* denotes special jurisdictional note) :

DELAWARE, FAIRFIELD, FRANKLIN, GUERNSEY, LICKING, MADISON, MARION, MUSKINGUM, MORGAN, NOBLE, PERRY, PICKAWAY, UNION

The first carpenter on the job shall be a journeyman. The second carpenter employed may be an apprentice carpenter. After one (1) journeyman and one (1) apprentice are employed, each employer shall employ a ratio of one (1) apprentice, when available, to two (2) journeyman.

Special Jurisdictional Note :

Details :

CARPENTERS duties shall include but not limited to the milling, fashioning, joining, assembling, erecting, fastening, or dismantling of scaffolding and of material of wood, plastic, metal, fiber, cork and composition, and all other substitute materials. The handling, cleaning, erecting, installing and dismantling of machinery, equipment and all materials used by carpenters.

The building and setting of all concrete forms and decking, and dismantling the same; the setting of templates for anchor bolts for structural members and for machinery, and the placing, leveling and bracing of these bolts; the making of all forms for bulkheads, figures, post, balusters and ornaments. The erection and installation of cooling towers assembled onsite. The building of all barricades and handling of rough lumber and drywall. The installation of all required blocking and all toilet accessories, including but not limited to grab bars, napkin dispensers and receptacles, mirrors and soap dispensers. The installation of metal studs and the welding of studs and other fastenings to receive material being applied by carpenters. The installation of all material used in

drywall construction such as plasterboard, transite and other composition boards. The installation of carpet, artificial turf, wood and Resilient floors shall consist of and include the laying of all special designs of wood, wood block, wood composition, cork, linoleum, asphalt, mastic, plastic and rubber tile, whether nailed or laid in, or with linoleum paste or glue compositions. The installation of garage and overhead doors. The installation of fixtures, cabinets, shelving, racks, louvers, etc. The assembling and setting of all seats in theaters, halls, churches, schools, auditoriums, grandstands and other buildings.

Our claim of jurisdiction, therefore, extends over the following subdivisions of the trade. Carpenters and Joiners; Bridge, Dock and Wharf Carpenters, Divers, Underpinners, Timbermen and Core Drillers; Shipwrights, Boat Builders, Ship Carpenters, Joiners and Caulkers, Cabinet Makers, Bench Hands, Stair Builders; Millmen; Wood and Resilient Floor Layers and Finishers; Carpet Layers; Shinglers; Siders; Insulators; Acoustic and Drywall Applicators; Shorers and House Movers; Loggers; Lumber and Sawmill Workers; Furniture Workers; Reed and Rattan Workers; Shingle Weavers; Casket and Coffin Makers; Box Makers; Railroad Carpenters; and Car Builders, regardless of material used; and all those engaged in the operation of woodworking or other machinery required in the fashioning, milling or manufacturing of products used in the trade, or engaged as helpers to any of the above divisions or subdivisions, and the handling, erecting and installing of material on any of the above divisions or subdivisions; burning welding, rigging and the use of any instrument or tool for layout work incidental to the trade. When the term "Carpenter" and "Joiner" is used, it shall mean all the subdivisions of the trade.

PILEDRIVER:

Where piling is used in the construction and repair of all wharves, docks, piers, trestles, caissons, cofferdams, the erection of all sea walls and breakwaters.

The placing of all walling, bumper guards of wood or metal. The framing, boring, drilling or burning of all holes in the same, all tie and hog rods in connection with Piledrivers work.

The driving, bracing, plumbing, cutting-off and capping of all piling whether wood, steel sheeting, metal pipe piling, composite or concrete.

The heading and splicing of wood piling and the making of woodsheet piling, The welding, cutting or burning of any metal and wood piling and shoring and underpinning in connection with Piledriver work.

The loading and unloading of all piling and other material used in connection with Piledrivers work.

The loading, unloading, erecting, framing, dismantling, moving and handling of all drivers, derrick, cranes and other piledriving equipment used in the work. Drilling in piling or drilled in caissons where a steel liner is used.

All machinery used for handling spuds or anchors on floating equipment used in our work shall be operated by our members. Where swing lines or derricks are used, members shall be used as watchmen.

All underwater and marine work on all bulkheads, wharves, docks, shipyards, caissons, piers, bridges, pipeline work, viaducts, marine cable and trestles, as well as salvage and reclamation work where divers are employed.

All clamming work that is done by floating derricks.

An Official State of Ohio site. [Here's how you know](#)

Prevailing Wage Rates - Skilled Crafts

Details

Union	Change#	Craft	Effective Date	Posted Date
Carpenter & Piledriver SC District HevHwy	LCR01-2025ib	Carpenter	07/09/2025	07/09/2025

Wage Rates

		Fringe Benefit Payments						Irrevocable Fund		Total PWR	Overtime Rate
		H&W	Pension	App Tr.	Vac.	Annuity	Other	LECET (*)	MISC (*)		
Classification	BHR										
Journeyman	\$35.69	\$8.85	\$10.78	\$0.70	\$0.00	\$2.91	\$0.16	\$0.00	\$0.00	\$59.09	\$76.94
Apprentice	Percent	BHR									
1st 6 months	70.000000	\$24.98	\$8.85	\$10.78	\$0.70	\$0.00	\$2.91	\$0.16	\$0.00	\$48.38	\$60.87
2nd 6 months	70.000000	\$24.98	\$8.85	\$10.78	\$0.70	\$0.00	\$2.91	\$0.16	\$0.00	\$48.38	\$60.87
3rd 6 months	80.000000	\$28.55	\$8.85	\$10.78	\$0.70	\$0.00	\$2.91	\$0.16	\$0.00	\$51.95	\$66.23
4th 6 months	80.000000	\$28.55	\$8.85	\$10.78	\$0.70	\$0.00	\$2.91	\$0.16	\$0.00	\$51.95	\$66.23
5th 6 months	90.000000	\$32.12	\$8.85	\$10.78	\$0.70	\$0.00	\$2.91	\$0.16	\$0.00	\$55.52	\$71.58
6th 6 months	90.000000	\$32.12	\$8.85	\$10.78	\$0.70	\$0.00	\$2.91	\$0.16	\$0.00	\$55.52	\$71.58
7th 6 months	95.000000	\$33.91	\$8.85	\$10.78	\$0.70	\$0.00	\$2.91	\$0.16	\$0.00	\$57.31	\$74.26
8th 6 months	95.000000	\$33.91	\$8.85	\$10.78	\$0.70	\$0.00	\$2.91	\$0.16	\$0.00	\$57.31	\$74.26

Special Calculation Note

Other: UBC National Fund

When the contractor furnishes the necessary underwater gear for the diver, the diver shall be paid one and one half (1 & 1/2) times the journeyman rate for the time spent in the water.

Ratio

1 Journeymen to 1 Apprentice

Jurisdiction (* denotes special jurisdictional note)

Adams, Athens, Delaware, Fairfield, Fayette, Franklin, Gallia, Guernsey, Highland, Hocking, Jackson, Lawrence, Licking, Madison, Marion, Meigs, Morgan, Muskingum, Noble, Perry, Pickaway, Pike, Ross, Scioto, Union, Vinton, Washington

Special Jurisdictional Note

Details

**Highway Construction, Airport Construction, Heavy Construction but not limited to: Tunnels, subways, drainage projects, flood control, reservoirs

Railroad Construction, Sewer Waterworks & Utility Construction but not limited to: storm sewers, waterlines, gas lines

Industrial & Building site, Power Plant, Amusement Park, Athletic stadium site, Sewer and Water Plants.

Prevailing Wage Rate Skilled Crafts

Name of Union: Carpenter Millwright Local 1090 Columbus

Change # : LCN01-2025ibLoc1090Columbus

Craft : Carpenter Effective Date : 05/13/2025 Last Posted : 05/13/2025

	BHR		Fringe Benefit Payments						Irrevocable Fund		Total PWR	Overtime Rate
			H&W	Pension	App Tr.	Vac.	Annuity	Other	LECET (*)	MISC (*)		
Classification												
Carpenter Millwright	\$35.59		\$8.85	\$10.99	\$0.70	\$0.00	\$7.20	\$0.16	\$0.00	\$0.00	\$63.49	\$81.29
Apprentice												
	Percent											
1st 6 months	70.00	\$24.91	\$8.85	\$10.99	\$0.70	\$0.00	\$7.20	\$0.16	\$0.00	\$0.00	\$52.81	\$65.27
2nd 6 months	70.00	\$24.91	\$8.85	\$10.99	\$0.70	\$0.00	\$7.20	\$0.16	\$0.00	\$0.00	\$52.81	\$65.27
3rd 6 months	80.00	\$28.47	\$8.85	\$10.99	\$0.70	\$0.00	\$7.20	\$0.16	\$0.00	\$0.00	\$56.37	\$70.61
4th 6 months	80.00	\$28.47	\$8.85	\$10.99	\$0.70	\$0.00	\$7.20	\$0.16	\$0.00	\$0.00	\$56.37	\$70.61
5th 6 months	90.00	\$32.03	\$8.85	\$10.99	\$0.70	\$0.00	\$7.20	\$0.16	\$0.00	\$0.00	\$59.93	\$75.95
6th 6 months	90.00	\$32.03	\$8.85	\$10.99	\$0.70	\$0.00	\$7.20	\$0.16	\$0.00	\$0.00	\$59.93	\$75.95
7th 6 months	95.00	\$33.81	\$8.85	\$10.99	\$0.70	\$0.00	\$7.20	\$0.16	\$0.00	\$0.00	\$61.71	\$78.62
8th 6 months	95.00	\$33.81	\$8.85	\$10.99	\$0.70	\$0.00	\$7.20	\$0.16	\$0.00	\$0.00	\$61.71	\$78.62

Special Calculation Note : Other is for UBC National Fund.

Ratio :

3 Journeymen to 1 Apprentice

Jurisdiction (* denotes special jurisdictional note) :

DELAWARE, FAIRFIELD, FRANKLIN, GUERNSEY, LICKING, MADISON, MARION, MORGAN, MUSKINGUM, NOBLE, PERRY, PICKAWAY, UNION

Special Jurisdictional Note :

Details :

The term “Millwright and Machine Erectors” jurisdiction shall mean the unloading, hoisting, rigging, skidding, moving, dismantling, aligning, erecting, assembling, repairing, maintenance and adjusting of all structures, processing areas either under cover, underground or elsewhere, required to process material, handle, manufacture

or service, be it powered or receiving power manually, by steam, gas, electricity, gasoline, diesel, nuclear, solar, water, air or chemically, and in industries such as and including, which are identified for the purpose of description, but not limited to, the following: woodworking plants; canning industries; steel mills; coffee roasting plants; paper and pulp; cellophane; stone crushing; gravel and sand washing and handling; refineries; grain storage and handling; asphalt plants; sewage disposal; water plants; laundries; bakeries; mixing plants; can, bottle and bag packing plants; textile mills; paint mills; breweries; milk processing plants; power plants; aluminum processing or manufacturing plants; and amusement and entertainment fields. The installation of mechanical equipment in atomic energy plants; installation of reactors in power plants; installation of control rods and equipment in reactors; and installation of mechanical equipment in rocket missile bases, launchers, launching gantry, floating bases, hydraulic escape doors and any and all component parts thereto, either assembled, semi-assembled or disassembled. The installation of, but not limited to, the following: setting-up of all engines, motors, generators, air compressors, fans, pumps, scales, hoppers, conveyors of all types, sizes and their supports; escalators; man lifts; moving sidewalks; hosts; dumb waiters; all types of feeding machinery; amusement devices; mechanical pin setters and spotters in bowling alleys; refrigeration equipment; and the installation of all types of equipment necessary and required to process material either in the manufacturing or servicing. The handling and installation of pulleys, gears, sheaves, fly wheels, air and vacuum drives, worm drives and gear drivers directly or indirectly coupled to motors, belts, chains, screws, legs, boots, guards, booth tanks, all bin valves, turn heads and indicators, shafting, bearings, cable sprockets cutting all key seats in new and old work, troughs, chippers, filters, calendars, rolls, winders, rewinders, slitters, cutters, wrapping machines, blowers, forging machines, rams, hydraulic or otherwise, planning, extruder, ball, dust collectors, equipment in meat packing plants, splicing or ropes and cables. The laying-out, fabrication and installation of protection equipment including machinery guards, making and setting of templates for machinery, fabrication of bolts, nuts, pans, dripping of holes for any equipment which the Millwrights install regardless of materials; all welding and burning regardless of type, fabrication of all lines, hose or tubing used in lubricating machinery installed by Millwrights; grinding, cleaning, servicing and any machine work necessary for any part of any equipment installed by the Millwrights; and the break-in and trail run of any equipment or machinery installed by the Millwrights. It is agreed the Millwrights shall use the layout tools and optic equipment necessary to perform their work.

Prevailing Wage Rate Skilled Crafts

Name of Union: Carpenter NE District Industrial Dock & Door

Change # : LCN01-2014fbCarpNEStatewide

Craft : Carpenter Effective Date : 03/05/2014 Last Posted : 03/05/2014

	BHR		Fringe Benefit Payments					Irrevocable Fund		Total PWR	Overtime Rate	
			H&W	Pension	App Tr.	Vac.	Annuity	Other	LECET (*)			MISC (*)
Classification												
Carpenter	\$19.70		\$5.05	\$1.00	\$0.15	\$0.00	\$0.00	\$0.00	\$0.00	\$0.00	\$25.90	\$35.75
Trainee												
	Percent											
1st Year	60.00	\$11.82	\$5.05	\$1.00	\$0.15	\$0.00	\$0.00	\$0.00	\$0.00	\$0.00	\$18.02	\$23.93
2nd Year	80.20	\$15.80	\$5.05	\$1.00	\$0.15	\$0.00	\$0.00	\$0.00	\$0.00	\$0.00	\$22.00	\$29.90

Special Calculation Note : No special calculations for this skilled craft wage rate are required at this time.

Ratio :

1 Journeymen to 1 Trainee

Jurisdiction (* denotes special jurisdictional note) :

ADAMS, ALLEN, ASHLAND, ASHTABULA, ATHENS, AUGLAIZE, BELMONT, BROWN, BUTLER, CARROLL, CHAMPAIGN, CLARK, CLERMONT, CLINTON, COLUMBIANA, COSHOCTON, CRAWFORD, CUYAHOGA, DARKE, DEFIANCE, DELAWARE, ERIE, FAIRFIELD, FAYETTE, FRANKLIN, FULTON, GALLIA, GEAUGA, GREENE, GUERNSEY, HAMILTON, HANCOCK, HARDIN, HARRISON, HENRY, HIGHLAND, HOCKING, HOLMES, HURON, JACKSON, JEFFERSON, KNOX, LAKE, LAWRENCE, LICKING, LOGAN, LORAIN, LUCAS, MADISON, MAHONING, MARION, MEDINA, MEIGS, MERCER, MIAMI, MONROE, MONTGOMERY, MORGAN, MORROW, MUSKINGUM, NOBLE, OTTAWA, PAULDING, PERRY, PICKAWAY, PIKE, PORTAGE, PREBLE, PUTNAM, RICHLAND, ROSS, SANDUSKY, SCIOTO, SENECA, SHELBY, STARK, SUMMIT, TRUMBULL, TUSCARAWAS, UNION, VAN WERT, VINTON, WARREN, WASHINGTON, WAYNE, WILLIAMS, WOOD, WYANDOT

Special Jurisdictional Note : Industrial Dock and Door is the installation of overhead doors, roll up doors and dock leveling equipment

Details :

10/27/10 New Contract jc

Prevailing Wage Rate Skilled Crafts

Name of Union: Cement Mason Local 132 (Columbus)

Change # : LCN01-2025ibLoc132Columbus

Craft : Cement Effective Date : 06/04/2025 Last Posted : 06/04/2025

	BHR		Fringe Benefit Payments					Irrevocable Fund		Total PWR	Overtime Rate	
			H&W	Pension	App Tr.	Vac.	Annuity	Other	LECET (*)			MISC (*)
Classification												
Cement Mason	\$35.12		\$8.90	\$4.65	\$0.75	\$0.00	\$3.10	\$0.06	\$0.00	\$0.00	\$52.58	\$70.14
Apprentice	Percent											
1st Year	70.00	\$24.58	\$8.90	\$4.65	\$0.75	\$0.00	\$3.10	\$0.06	\$0.00	\$0.00	\$42.04	\$54.34
2nd Year	80.00	\$28.10	\$8.90	\$4.65	\$0.75	\$0.00	\$3.10	\$0.06	\$0.00	\$0.00	\$45.56	\$59.60
3rd Year	90.00	\$31.61	\$8.90	\$4.65	\$0.75	\$0.00	\$3.10	\$0.06	\$0.00	\$0.00	\$49.07	\$64.87

Special Calculation Note : Other: International Training Fund

Ratio :

3 Journeymen to 1 Apprentice

Jurisdiction (* denotes special jurisdictional note) :

ASHLAND, COSHOCTON, CRAWFORD, DELAWARE, FAIRFIELD, FAYETTE, FRANKLIN, GUERNSEY, HOCKING, KNOX, LICKING, MADISON, MARION, MORROW, MUSKINGUM, PERRY, PICKAWAY, RICHLAND, ROSS, UNION, VINTON, WYANDOT

Special Jurisdictional Note :

Details :

Working on swing stage, slip scaffold, window jack scaffold, scissor lifts, and aerial lifts shall receive the following rates:

- \$.50 above the regular rate for heights up to fifty (50) feet above grade level
- \$ 1.00 above the regular rate for heights over fifty (50) feet above grade level

Prevailing Wage Rate Skilled Crafts

Name of Union: Cement Mason Statewide HevHwy

Change # : LCN01-2024ibCementHevHwy

Craft : Cement Mason Effective Date : 05/01/2024 Last Posted : 05/01/2024

	BHR		Fringe Benefit Payments					Irrevocable Fund		Total PWR	Overtime Rate	
			H&W	Pension	App Tr.	Vac.	Annuity	Other	LECET (*)			MISC (*)
Classification												
Cement Mason	\$34.74		\$8.80	\$7.65	\$0.75	\$0.00	\$2.25	\$0.07	\$0.00	\$0.00	\$54.26	\$71.63
Apprentice	Percent											
1st Year	70.00	\$24.32	\$8.80	\$7.65	\$0.75	\$0.00	\$2.25	\$0.07	\$0.00	\$0.00	\$43.84	\$56.00
2nd Year	80.00	\$27.79	\$8.80	\$7.65	\$0.75	\$0.00	\$2.25	\$0.07	\$0.00	\$0.00	\$47.31	\$61.21
3rd Year	90.00	\$31.27	\$8.80	\$7.65	\$0.75	\$0.00	\$2.25	\$0.07	\$0.00	\$0.00	\$50.79	\$66.42
4th Year	95.00	\$33.00	\$8.80	\$7.65	\$0.75	\$0.00	\$3.25	\$0.07	\$0.00	\$0.00	\$53.52	\$70.02

Special Calculation Note : Other \$0.07 is for International Training Fund

4th Year Apprentice Rate (95%) is only applicable to the jurisdiction of Local 404, this includes Ashtabula, Cuyahoga, Geauga, Lake, and Lorain counties.

Ratio :

1 Journeymen to 1 Apprentice
2 to 1 thereafter

Jurisdiction (* denotes special jurisdictional note) :

ADAMS, ALLEN, ASHLAND, ASHTABULA*, ATHENS, AUGLAIZE, BELMONT, BROWN, BUTLER, CARROLL, CHAMPAIGN, CLARK, CLERMONT, CLINTON, COLUMBIANA, COSHOCTON, CRAWFORD, CUYAHOGA*, DARKE, DEFIANCE, DELAWARE, ERIE, FAIRFIELD, FAYETTE, FRANKLIN, FULTON*, GALLIA, GEAUGA*, GREENE, GUERNSEY, HAMILTON, HANCOCK*, HARDIN, HARRISON, HENRY*, HIGHLAND, HOCKING, HOLMES, HURON, JACKSON, JEFFERSON, KNOX, LAKE*, LAWRENCE, LICKING, LOGAN, LORAIN, LUCAS*, MADISON, MAHONING, MARION, MEDINA, MEIGS, MERCER, MIAMI, MONROE, MONTGOMERY, MORGAN, MORROW, MUSKINGUM, NOBLE, OTTAWA, PAULDING, PERRY, PICKAWAY, PIKE, PORTAGE, PREBLE, PUTNAM*, RICHLAND, ROSS, SANDUSKY, SCIOTO, SENECA, SHELBY, STARK, SUMMIT, TRUMBULL, TUSCARAWAS, UNION, VAN WERT, VINTON, WARREN, WASHINGTON, WAYNE, WILLIAMS, WOOD*, WYANDOT

Special Jurisdictional Note : (A) Highway Construction, Sewer, Waterworks And Utility Construction, Industrial & Building Site, Heavy Construction, Airport Construction Or Railroad Construction Work, Power Plant, Tunnels, Amusement Park, Athletic Stadium Site Work, Pollution Control, Sewer Plant, Waste & Water Plant, Water Treatment Facilities Construction.

*For Power Plant, Tunnels, Amusement Park, Athletic Stadium Site Work, Pollution Control, Sewer Plant, Waste & Water Plant, Water Treatment Facility Construction work in the following Counties: Ashtabula, Cuyahoga, Fulton, Geauga, Hancock, Henry, Lake, Lucas, Putnam and Wood Counties, those counties will use the Cement Mason Statewide Heavy Highway Exhibit B District 1 Wage Rate.

Details :

This rate replaces the previous Cement Mason Heavy Highway Statewide Rates (Exhibit A and Exhibit B rates), except for Cement Mason Statewide Heavy Highway Exhibit B Dist 1. sks

Prevailing Wage Rate Skilled Crafts

Name of Union: **Electrical Local 71 High Tension Pipe Type Cable**

Change # : LCN02-2024ibLoc71HTPC

Craft : Lineman Effective Date : 01/06/2025 Last Posted : 12/31/2024

	BHR	Fringe Benefit Payments						Irrevocable Fund		Total PWR	Overtime Rate
		H&W	Pension	App Tr.	Vac.	Annuity	Other	LECET (*)	MISC (*)		
Classification											
Electrical Lineman	\$52.94	\$7.50	\$1.59	\$0.53	\$0.00	\$12.71	\$0.75	\$0.00	\$0.00	\$76.02	\$102.49
Certified Lineman Welder	\$52.94	\$7.50	\$1.59	\$0.53	\$0.00	\$12.71	\$0.75	\$0.00	\$0.00	\$76.02	\$102.49
Certified Cable Splicer	\$52.94	\$7.50	\$1.59	\$0.53	\$0.00	\$12.71	\$0.75	\$0.00	\$0.00	\$76.02	\$102.49
Operator A	\$47.43	\$7.50	\$1.42	\$0.47	\$0.00	\$11.38	\$0.75	\$0.00	\$0.00	\$68.95	\$92.66
Operator B	\$41.99	\$7.50	\$1.26	\$0.42	\$0.00	\$10.08	\$0.75	\$0.00	\$0.00	\$62.00	\$83.00
Operator C	\$33.74	\$7.50	\$1.01	\$0.34	\$0.00	\$8.10	\$0.75	\$0.00	\$0.00	\$51.44	\$68.31
Groundman 0-12 months Exp	\$26.47	\$7.50	\$0.79	\$0.26	\$0.00	\$6.35	\$0.75	\$0.00	\$0.00	\$42.12	\$55.35
Groundman 0-12 months Exp w/CDL	\$29.12	\$7.50	\$0.87	\$0.29	\$0.00	\$6.99	\$0.75	\$0.00	\$0.00	\$45.52	\$60.08
Groundman 1 yr or more	\$29.12	\$7.50	\$0.87	\$0.29	\$0.00	\$6.99	\$0.75	\$0.00	\$0.00	\$45.52	\$60.08
Groundman 1 yr or more w/CDL	\$34.41	\$7.50	\$1.03	\$0.34	\$0.00	\$8.26	\$0.75	\$0.00	\$0.00	\$52.29	\$69.50
Equipment Mechanic A	\$41.99	\$7.50	\$1.26	\$0.42	\$0.00	\$10.08	\$0.75	\$0.00	\$0.00	\$62.00	\$83.00
Equipment Mechanic B	\$37.86	\$7.50	\$1.14	\$0.38	\$0.00	\$9.09	\$0.75	\$0.00	\$0.00	\$56.72	\$75.65
Equipment Mechanic C	\$33.74	\$7.50	\$1.01	\$0.34	\$0.00	\$8.10	\$0.75	\$0.00	\$0.00	\$51.44	\$68.31

X-Ray Technician	\$52.94	\$7.50	\$1.59	\$0.53	\$0.00	\$12.71	\$0.75	\$0.00	\$0.00	\$76.02	\$102.49	
Apprentice	Percent											
1st 1000 hrs	60.00	\$31.76	\$7.50	\$0.95	\$0.32	\$0.00	\$7.62	\$0.75	\$0.00	\$0.00	\$48.90	\$64.79
2nd 1000 hrs	65.00	\$34.41	\$7.50	\$1.03	\$0.34	\$0.00	\$8.26	\$0.75	\$0.00	\$0.00	\$52.29	\$69.50
3rd 1000 hrs	70.00	\$37.06	\$7.50	\$1.11	\$0.37	\$0.00	\$8.89	\$0.75	\$0.00	\$0.00	\$55.68	\$74.21
4th 1000 hrs	75.00	\$39.71	\$7.50	\$1.19	\$0.40	\$0.00	\$9.53	\$0.75	\$0.00	\$0.00	\$59.07	\$78.93
5th 1000 hrs	80.00	\$42.35	\$7.50	\$1.27	\$0.42	\$0.00	\$10.16	\$0.75	\$0.00	\$0.00	\$62.45	\$83.63
6th 1000 hrs	85.00	\$45.00	\$7.50	\$1.35	\$0.45	\$0.00	\$10.80	\$0.75	\$0.00	\$0.00	\$65.85	\$88.35
7th 1000 hrs	90.00	\$47.65	\$7.50	\$1.43	\$0.48	\$0.00	\$11.44	\$0.75	\$0.00	\$0.00	\$69.25	\$93.07

Special Calculation Note : Other is Health Retirement Account

Operator "A"

John Henry Rock Drill, D-6 (or equivalent) and above, Trackhoe Digger, (320 Track excavator), Cranes (greater than 25 tons and less than 45 tons).

Operator "B"

Cranes (greater than 6 tons and up to 25 tons), Backhoes, Road Tractor, Dozer up to D-5, Pressure Digger- wheeled or tracked, all Tension wire Stringing equipment.

Operator "C"

Trench, Backhoe, Riding type vibratory Compactor, Ground Rod Driver, Boom Truck (6 ton & below), Skid Steer Loaders, Material Handler.

*All Operators of cranes 45 ton or larger shall be paid the journeyman rate of pay. \$0.30 is for Health Retirement Account.

Ratio :

1 Journeyman to 1 Apprentice

Jurisdiction (* denotes special jurisdictional note) :

ADAMS, ASHLAND, ASHTABULA, ATHENS, AUGLAIZE, BELMONT, BROWN, BUTLER, CARROLL, CHAMPAIGN, CLARK, CLERMONT, CLINTON, COLUMBIANA, COSHOCTON, CRAWFORD, CUYAHOGA, DARKE, DELAWARE, FAIRFIELD, FAYETTE, FRANKLIN, GALLIA, GEAUGA, GREENE, GUERNSEY, HAMILTON, HARRISON, HIGHLAND, HOCKING, HOLMES, JACKSON, JEFFERSON, KNOX, LAKE, LAWRENCE, LICKING, LOGAN, LORAIN, MADISON, MAHONING, MARION, MEDINA, MEIGS, MERCER, MIAMI, MONROE, MONTGOMERY, MORGAN, MORROW, MUSKINGUM, NOBLE, PERRY, PICKAWAY, PIKE, PORTAGE, PREBLE, RICHLAND, ROSS, SCIOTO,

SHELBY, STARK, SUMMIT, TRUMBULL,
TUSCARAWAS, UNION, VINTON, WARREN,
WASHINGTON, WAYNE

Special Jurisdictional Note :

Details :

Heli - Arc Welding will be paid \$.30 above Journeyman rate. Additional compensation of 10% over the Journeyman Lineman and Journeyman Technician for performing work on structures outside of buildings such as water towers, smoke stacks, radio and television towers, more than 75' above the ground.

Prevailing Wage Rate Skilled Crafts

Name of Union: Electrical Local 71 Outside (Central OH Chapter)

Change # : LCN01-2025ibLoc71CentralOhio

Craft : Lineman Effective Date : 06/04/2025 Last Posted : 06/04/2025

	BHR		Fringe Benefit Payments					Irrevocable Fund		Total PWR	Overtime Rate	
			H&W	Pension	App Tr.	Vac.	Annuity	Other	LECET (*)			MISC (*)
Classification												
Electrical Lineman	\$46.03		\$7.50	\$1.38	\$0.46	\$0.00	\$9.20	\$0.50	\$0.00	\$0.00	\$65.07	\$88.08
Traffic Signal & Lighting Journeyman	\$44.43		\$7.50	\$1.33	\$0.44	\$0.00	\$8.89	\$0.50	\$0.00	\$0.00	\$63.09	\$85.30
Equipment Operator	\$40.44		\$7.50	\$1.21	\$0.40	\$0.00	\$8.09	\$0.50	\$0.00	\$0.00	\$58.14	\$78.36
Groundman 0-12 months (W/O CDL)	\$24.52		\$7.50	\$0.74	\$0.25	\$0.00	\$4.90	\$0.50	\$0.00	\$0.00	\$38.41	\$50.67
Groundman 0-12 Months W/CDL	\$26.78		\$7.50	\$0.80	\$0.27	\$0.00	\$5.36	\$0.50	\$0.00	\$0.00	\$41.21	\$54.60
Groundman greater than 1 Year W/CDL	\$29.07		\$7.50	\$0.87	\$0.29	\$0.00	\$5.81	\$0.50	\$0.00	\$0.00	\$44.04	\$58.58
Traffic Signal Apprentices												
1st 1,000 hours	\$26.66		\$7.50	\$0.80	\$0.27	\$0.00	\$5.33	\$0.50	\$0.00	\$0.00	\$41.06	\$54.39
2nd 1,000 hours	\$28.88		\$7.50	\$0.87	\$0.29	\$0.00	\$5.78	\$0.50	\$0.00	\$0.00	\$43.82	\$58.26
3rd 1,000 hours	\$31.10		\$7.50	\$0.93	\$0.31	\$0.00	\$6.22	\$0.50	\$0.00	\$0.00	\$46.56	\$62.11
4th 1,000 hours	\$33.32		\$7.50	\$1.00	\$0.33	\$0.00	\$6.66	\$0.50	\$0.00	\$0.00	\$49.31	\$65.97
5th 1,000 hours	\$35.54		\$7.50	\$1.07	\$0.36	\$0.00	\$7.11	\$0.50	\$0.00	\$0.00	\$52.08	\$69.85
6th 1,000 hours	\$39.99		\$7.50	\$1.20	\$0.40	\$0.00	\$8.00	\$0.50	\$0.00	\$0.00	\$57.59	\$77.59
Apprentice Lineman	Percent											
1st 1,000 Hours	60.00	\$27.62	\$7.50	\$0.83	\$0.28	\$0.00	\$5.52	\$0.50	\$0.00	\$0.00	\$42.25	\$56.06
2nd 1,000 Hours	65.00	\$29.92	\$7.50	\$0.90	\$0.30	\$0.00	\$5.98	\$0.50	\$0.00	\$0.00	\$45.10	\$60.06
3rd 1,000 Hours	70.00	\$32.22	\$7.50	\$0.97	\$0.32	\$0.00	\$6.44	\$0.50	\$0.00	\$0.00	\$47.95	\$64.06
4th 1,000 Hours	75.00	\$34.52	\$7.50	\$1.04	\$0.35	\$0.00	\$6.90	\$0.50	\$0.00	\$0.00	\$50.81	\$68.07
5th 1,000 Hours	80.00	\$36.82	\$7.50	\$1.10	\$0.37	\$0.00	\$7.36	\$0.50	\$0.00	\$0.00	\$53.65	\$72.07
6th 1,000 Hours	85.00	\$39.13	\$7.50	\$1.17	\$0.39	\$0.00	\$7.82	\$0.50	\$0.00	\$0.00	\$56.51	\$76.07
7th 1,000 Hours	90.00	\$41.43	\$7.50	\$1.24	\$0.41	\$0.00	\$8.28	\$0.50	\$0.00	\$0.00	\$59.36	\$80.07

Special Calculation Note : Other is Health Reimbursment Account**Ratio :**

1 Journeymen to 1 Apprentice

Jurisdiction (* denotes special jurisdictional note) :

ADAMS, ASHLAND, ATHENS, COSHOCTON, CRAWFORD, DELAWARE, FAIRFIELD, FAYETTE, FRANKLIN, GALLIA, GUERNSEY, HIGHLAND, HOCKING, JACKSON, KNOX, LAWRENCE, LICKING, MADISON, MARION, MEIGS, MONROE, MORGAN, MORROW, MUSKINGUM, NOBLE, PERRY, PICKAWAY, PIKE, RICHLAND, ROSS, SCIOTO, TUSCARAWAS, UNION, VINTON, WASHINGTON

Special Jurisdictional Note :**Details :**

A groundman when directed shall assist a Journeyman Lineman, Traffic Signal and Lighting Journeyman or Equipment Operator in the performance of his/her work on the ground, including the use of hand tools. Under no circumstances shall this classification climb poles, towers, or work from an elevated platform or bucket truck. This classification shall not perform work normally assigned to an Apprentice.

No more than three (3) Groundmen shall work alone. Jobs with more that three Groundmen shall be supervised by a Groundcrew Foreman, Journeyman Lineman, Journeyman Traffic Signal Technician or an Equipment Operator.

Scope of Work: installation and maintenance of highway and street lighting, highway and street sign lighting, electronic message boards and traffic control systems, camera systems, traffic signal work, substation and line construction including overhead and underground projects for private and industrial work as in accordance with the IBEW Constitution. This Agreement includes the operation of all tools and equipment necessary for the installation of the above projects.

Prevailing Wage Rate Skilled Crafts

Name of Union: Electrical Local 71 Outside Utility Power

Change # : LCN01-2024ibLoc71

Craft : Lineman Effective Date : 01/06/2025 Last Posted : 12/31/2024

	BHR	Fringe Benefit Payments						Irrevocable Fund		Total PWR	Overtime Rate
		H&W	Pension	App Tr.	Vac.	Annuity	Other	LECET (*)	MISC (*)		
Classification											
Electrical Lineman	\$50.15	\$7.50	\$1.50	\$0.50	\$0.00	\$12.04	\$0.75	\$0.00	\$0.00	\$72.44	\$97.51
Substation Technician	\$50.15	\$7.50	\$1.50	\$0.50	\$0.00	\$12.04	\$0.75	\$0.00	\$0.00	\$72.44	\$97.51
Cable Splicer	\$52.52	\$7.50	\$1.58	\$0.52	\$0.00	\$12.60	\$0.75	\$0.00	\$0.00	\$75.47	\$101.73
Operator A	\$44.95	\$7.50	\$1.35	\$0.45	\$0.00	\$10.79	\$0.75	\$0.00	\$0.00	\$65.79	\$88.27
Operator B	\$39.73	\$7.50	\$1.19	\$0.40	\$0.00	\$9.53	\$0.75	\$0.00	\$0.00	\$59.10	\$78.96
Operator C	\$31.89	\$7.50	\$0.96	\$0.32	\$0.00	\$7.65	\$0.75	\$0.00	\$0.00	\$49.07	\$65.01
Groundman 0-12 months Exp	\$25.07	\$7.50	\$0.75	\$0.25	\$0.00	\$6.02	\$0.75	\$0.00	\$0.00	\$40.34	\$52.88
Groundman 0-12 months Exp w/CDL	\$27.58	\$7.50	\$0.83	\$0.28	\$0.00	\$6.62	\$0.75	\$0.00	\$0.00	\$43.56	\$57.35
Groundman 1 yr or more	\$27.58	\$7.50	\$0.83	\$0.28	\$0.00	\$6.62	\$0.75	\$0.00	\$0.00	\$43.56	\$57.35
Groundman 1 yr or more w/CDL	\$32.60	\$7.50	\$0.98	\$0.33	\$0.00	\$7.82	\$0.75	\$0.00	\$0.00	\$49.98	\$66.28
Equipment Mechanic A	\$39.73	\$7.50	\$1.19	\$0.40	\$0.00	\$9.54	\$0.75	\$0.00	\$0.00	\$59.11	\$78.97
Equipment Mechanic B	\$35.82	\$7.50	\$1.07	\$0.36	\$0.00	\$8.60	\$0.75	\$0.00	\$0.00	\$54.10	\$72.01
Equipment Mechanic C	\$31.89	\$7.50	\$0.96	\$0.32	\$0.00	\$7.65	\$0.75	\$0.00	\$0.00	\$49.07	\$65.01
Line Truck w/uuger	\$35.16	\$7.50	\$1.05	\$0.35	\$0.00	\$8.44	\$0.75	\$0.00	\$0.00	\$53.25	\$70.83

Apprentice	Percent											
1st 1000 hrs	60.00	\$30.09	\$7.50	\$0.90	\$0.30	\$0.00	\$7.22	\$0.75	\$0.00	\$0.00	\$46.76	\$61.80
2nd 1000 hrs	65.00	\$32.60	\$7.50	\$0.98	\$0.33	\$0.00	\$7.82	\$0.75	\$0.00	\$0.00	\$49.98	\$66.28
3rd 1000 hrs	70.00	\$35.10	\$7.50	\$1.05	\$0.35	\$0.00	\$8.43	\$0.75	\$0.00	\$0.00	\$53.18	\$70.74
4th 1000 hrs	75.00	\$37.61	\$7.50	\$1.13	\$0.38	\$0.00	\$9.03	\$0.75	\$0.00	\$0.00	\$56.40	\$75.21
5th 1000 hrs	80.00	\$40.12	\$7.50	\$1.20	\$0.40	\$0.00	\$9.63	\$0.75	\$0.00	\$0.00	\$59.60	\$79.66
6th 1000 hrs	85.00	\$42.63	\$7.50	\$1.28	\$0.43	\$0.00	\$10.23	\$0.75	\$0.00	\$0.00	\$62.82	\$84.13
7th 1000 hrs	90.00	\$45.14	\$7.50	\$1.35	\$0.45	\$0.00	\$10.83	\$0.75	\$0.00	\$0.00	\$66.01	\$88.58

Special Calculation Note : Other is Health Reimbursement Account

Operator "A"

John Henry Rock Drill, D-6 (or equivalent) and above, Trackhoe Digger, (320 Track excavator), Cranes (greater than 25 tons and less than 45 tons).

Operator "B"

Cranes (greater than 6 tons and up to 25 tons), Backhoes, Road Tractor, Dozer up to D-5, Pressure Digger- wheeled or tracked, all Tension wire Stringing equipment.

Operator "C"

Trench, Backhoe, Riding type vibratory Compactor, Ground Rod Driver, Boom Truck (6 ton & below), Skid Steer Loaders, Material Handler.

Ratio :

(1) Journeyman Lineman to (1) Apprentice

Jurisdiction (* denotes special jurisdictional note) :

ADAMS, ASHLAND, ASHTABULA, ATHENS, AUGLAIZE, BELMONT, BROWN, BUTLER, CARROLL, CHAMPAIGN, CLARK, CLERMONT, CLINTON, COLUMBIANA, COSHOCTON, CRAWFORD, CUYAHOGA, DARKE, DELAWARE, FAIRFIELD, FAYETTE, FRANKLIN, GALLIA, GEAUGA, GREENE, GUERNSEY, HAMILTON, HARRISON, HIGHLAND, HOCKING, HOLMES, JACKSON, JEFFERSON, KNOX, LAKE, LAWRENCE, LICKING, LOGAN, LORAIN, MADISON, MAHONING, MARION, MEDINA, MEIGS, MERCER, MIAMI, MONROE, MONTGOMERY, MORGAN, MORROW, MUSKINGUM, NOBLE, PERRY, PICKAWAY, PIKE, PORTAGE, PREBLE, RICHLAND, ROSS, SCIOTO, SHELBY, STARK, SUMMIT, TRUMBULL, TUSCARAWAS, UNION, VINTON, WARREN, WASHINGTON, WAYNE

Special Jurisdictional Note :

Details :

Heli - Arc Welding will be paid \$.30 above Journeyman rate. Additional compensation of 10% over the

Journeyman Lineman and Journeyman Technician for performing work on structures outside of buildings such as water towers, smoke stacks, radio and television towers, more than 75' above the ground.

Prevailing Wage Rate Skilled Crafts

Name of Union: Electrical Local 71 Underground Residential Distribution

Change # : LCN02-2024ibLoc7URD

Craft : Lineman Effective Date : 01/06/2025 Last Posted : 12/31/2024

	BHR		Fringe Benefit Payments					Irrevocable Fund		Total PWR	Overtime Rate	
			H&W	Pension	App Tr.	Vac.	Annuity	Other	LECET (*)			MISC (*)
Classification												
URD Electrician	\$38.05		\$7.50	\$1.14	\$0.38	\$0.00	\$9.13	\$0.75	\$0.00	\$0.00	\$56.95	\$75.97
Equipment Operator A	\$34.04		\$7.50	\$1.02	\$0.34	\$0.00	\$8.17	\$0.75	\$0.00	\$0.00	\$51.82	\$68.84
Equipment Operator B	\$31.26		\$7.50	\$0.94	\$0.31	\$0.00	\$7.50	\$0.75	\$0.00	\$0.00	\$48.26	\$63.89
Directional Drill Locator	\$34.04		\$7.50	\$1.02	\$0.34	\$0.00	\$8.17	\$0.75	\$0.00	\$0.00	\$51.82	\$68.84
Directional Drill Operator	\$31.26		\$7.50	\$0.94	\$0.31	\$0.00	\$7.50	\$0.75	\$0.00	\$0.00	\$48.26	\$63.89
Groundman 0-12 months Exp	\$24.70		\$7.50	\$0.74	\$0.25	\$0.00	\$5.93	\$0.75	\$0.00	\$0.00	\$39.87	\$52.22
Groundman 0-12 months Exp w/CDL	\$27.24		\$7.50	\$0.82	\$0.27	\$0.00	\$6.54	\$0.75	\$0.00	\$0.00	\$43.12	\$56.74
Groundman 1 yr or more	\$27.24		\$7.50	\$0.82	\$0.27	\$0.00	\$6.54	\$0.75	\$0.00	\$0.00	\$43.12	\$56.74
Groundman 1 yr or more w/CDL	\$32.26		\$7.50	\$0.97	\$0.32	\$0.00	\$7.74	\$0.75	\$0.00	\$0.00	\$49.54	\$65.67
Apprentice	Percent											
1st 1000 hrs	80.00	\$30.44	\$7.50	\$0.91	\$0.30	\$0.00	\$7.31	\$0.75	\$0.00	\$0.00	\$47.21	\$62.43
2nd 1000 hrs	85.00	\$32.34	\$7.50	\$0.97	\$0.32	\$0.00	\$7.76	\$0.75	\$0.00	\$0.00	\$49.64	\$65.81
3rd 1000 hrs	90.00	\$34.25	\$7.50	\$1.03	\$0.34	\$0.00	\$8.22	\$0.75	\$0.00	\$0.00	\$52.09	\$69.21

4th 1000 hrs	95.00	\$36.15	\$7.50	\$1.08	\$0.36	\$0.00	\$8.68	\$0.75	\$0.00	\$0.00	\$54.52	\$72.59
-----------------	-------	---------	--------	--------	--------	--------	--------	--------	--------	--------	---------	---------

Special Calculation Note : Other: Health Reimbursement Account

Ratio :

(1) Journeyman Lineman to (1) Apprentice

Jurisdiction (* denotes special jurisdictional note) :

ADAMS, ASHLAND, ASHTABULA, ATHENS, AUGLAIZE, BELMONT, BROWN, BUTLER, CARROLL, CHAMPAIGN, CLARK, CLERMONT, CLINTON, COLUMBIANA, COSHOCTON, CRAWFORD, CUYAHOGA, DARKE, DELAWARE, FAIRFIELD, FAYETTE, FRANKLIN, GALLIA, GEAUGA, GREENE, GUERNSEY, HAMILTON, HARRISON, HIGHLAND, HOCKING, HOLMES, JACKSON, JEFFERSON, KNOX, LAKE, LAWRENCE, LICKING, LOGAN, LORAIN, MADISON, MAHONING, MARION, MEDINA, MEIGS, MERCER, MIAMI, MONROE, MONTGOMERY, MORGAN, MORROW, MUSKINGUM, NOBLE, PERRY, PICKAWAY, PIKE, PORTAGE, PREBLE, RICHLAND, ROSS, SCIOTO, SHELBY, STARK, SUMMIT, TRUMBULL, TUSCARAWAS, UNION, VINTON, WARREN, WASHINGTON, WAYNE

Special Jurisdictional Note :

Details :

This work applies to projects designated for any outside Underground Residential Distribution construction work for electrical utilities, municipalities and rural electrification projects.

Prevailing Wage Rate Skilled Crafts

Name of Union: Electrical Local 71 Voice Data Video Outside

Change # : LCN02-2024ibLoc71VDV

Craft : Voice Data Video Effective Date : 03/06/2024 Last Posted : 03/06/2024

	BHR		Fringe Benefit Payments					Irrevocable Fund		Total PWR	Overtime Rate	
			H&W	Pension	App Tr.	Vac.	Annuity	Other	LECET (*)			MISC (*)
Classification												
Electrical Installer Technician I	\$35.39		\$7.25	\$1.06	\$0.00	\$0.00	\$1.77	\$0.00	\$0.00	\$0.00	\$45.47	\$63.17
Installer Technician II	\$33.37		\$7.25	\$1.00	\$0.00	\$0.00	\$1.67	\$0.00	\$0.00	\$0.00	\$43.29	\$59.97
Installer Repairman	\$33.37		\$7.25	\$1.00	\$0.00	\$0.00	\$1.67	\$0.00	\$0.00	\$0.00	\$43.29	\$59.97
Equipment Operator II	\$24.98		\$7.25	\$0.75	\$0.00	\$0.00	\$1.25	\$0.00	\$0.00	\$0.00	\$34.23	\$46.72
Cable Splicer	\$35.39		\$7.25	\$1.06	\$0.00	\$0.00	\$1.77	\$0.00	\$0.00	\$0.00	\$45.47	\$63.17
Ground Driver W/CDL	\$16.69		\$7.25	\$0.50	\$0.00	\$0.00	\$0.83	\$0.00	\$0.00	\$0.00	\$25.27	\$33.62
Groundman	\$14.57		\$7.25	\$0.44	\$0.00	\$0.00	\$0.73	\$0.00	\$0.00	\$0.00	\$22.99	\$30.28
Trainees	Percent											
Trainee F	50.02	\$17.70	\$7.25	\$0.53	\$0.00	\$0.89	\$0.00	\$0.00	\$0.00	\$0.00	\$26.37	\$35.22
Trainee E	58.00	\$20.53	\$7.25	\$0.62	\$0.00	\$1.03	\$0.00	\$0.00	\$0.00	\$0.00	\$29.43	\$39.69
Trainee D	66.00	\$23.36	\$7.25	\$0.70	\$0.00	\$1.17	\$0.00	\$0.00	\$0.00	\$0.00	\$32.48	\$44.16
Trainee C	74.00	\$26.19	\$7.25	\$0.79	\$0.00	\$1.31	\$0.00	\$0.00	\$0.00	\$0.00	\$35.54	\$48.63
Trainee B	82.00	\$29.02	\$7.25	\$0.87	\$0.00	\$1.45	\$0.00	\$0.00	\$0.00	\$0.00	\$38.59	\$53.10
Trainee A	90.00	\$31.85	\$7.25	\$0.96	\$0.00	\$1.59	\$0.00	\$0.00	\$0.00	\$0.00	\$41.65	\$57.58

Special Calculation Note :

Ratio :

1 Trainee to 1 Journeyman

Jurisdiction (* denotes special jurisdictional note) :

ADAMS, ASHLAND, ASHTABULA, ATHENS, AUGLAIZE, BELMONT, BROWN, BUTLER, CARROLL, CHAMPAIGN, CLARK, CLERMONT, CLINTON, COLUMBIANA, COSHOCTON, CRAWFORD, CUYAHOGA, DARKE, DELAWARE, FAIRFIELD, FAYETTE, FRANKLIN, GALLIA,

GEAUGA, GREENE, GUERNSEY, HAMILTON,
HARRISON, HIGHLAND, HOCKING, HOLMES,
JACKSON, JEFFERSON, KNOX, LAKE,
LAWRENCE, LICKING, LOGAN, LORAIN,
MADISON, MAHONING, MARION, MEDINA,
MEIGS, MERCER, MIAMI, MONROE,
MONTGOMERY, MORGAN, MORROW,
MUSKINGUM, NOBLE, PERRY, PICKAWAY, PIKE,
PORTAGE, PREBLE, RICHLAND, ROSS, SCIOTO,
SHELBY, STARK, SUMMIT, TRUMBULL,
TUSCARAWAS, UNION, VINTON, WARREN,
WASHINGTON, WAYNE

Special Jurisdictional Note :

Details :

Cable Splicer: Inspect and test lines or cables, analyze results, and evaluate transmission characteristics. Cover conductors with insulation or seal splices with moisture-proof covering. Install, splice, test, and repair cables using tools or mechanical equipment. This will include the splicing of fiber.

Installer Technician I: Must know all aspects of telephone and cable work. This is to include aerial, underground, and manhole work. Must know how to climb and run bucket. Must have all the tools required to perform these tasks. Must be able to be responsible for the safety of the crew at all times. Must also have CDL license and have at least 5 years experience.

Installer Repairman: Perform tasks of repairing, installing, and testing phone and CATV services.

Installer Technician II: Have at least three years of telephone and CATV experience. Must have the knowledge of underground, aerial, and manhole work. Must be able to climb and operate bucket. Must have CDL. Must have all tools needed to perform these tasks.

Equipment Operator II: Able to operate a digger derrick or bucket truck. Have at least 3 years of experience and must have a valid CDL license.

Groundman W/CDL: Must have a valid CDL license and be able to perform tasks such as: climbing poles, pulling down guys, making up material, and getting appropriate tools for the job. Must have at least 5 year's experience.

Groundman: Perform tasks such as: climbing poles, pulling down guys, making up material, and getting appropriate tools for the job. Experience 0-5 years.

An Official State of Ohio site. [Here's how you know](#)

Prevailing Wage Rates - Skilled Crafts

Details

Union	Change#	Craft	Effective Date	Posted Date
Electrical Local 683 Inside Lt Commercial South West	LCN02-2025ib	Electrical	08/13/2025	08/13/2025

Wage Rates

	BHR	Fringe Benefit Payments						Irrevocable Fund		Total PWR	Overtime Rate
		H&W	Pension	App Tr.	Vac.	Annuity	Other	LECET (*)	MISC (*)		
Classification	BHR										
Electrician	\$43.00	\$12.15	\$8.81	\$1.16	\$0.00	\$4.25	\$0.00	\$0.00	\$0.00	\$69.37	\$90.87
Welding	\$44.00	\$12.15	\$8.84	\$1.16	\$0.00	\$4.25	\$0.00	\$0.00	\$0.00	\$70.40	\$92.40
Medium Voltage Splicing	\$44.00	\$12.15	\$8.84	\$1.16	\$0.00	\$4.25	\$0.00	\$0.00	\$0.00	\$70.40	\$92.40
Over 100 feet	\$64.50	\$12.15	\$9.46	\$1.16	\$0.00	\$4.25	\$0.00	\$0.00	\$0.00	\$91.52	\$123.77
Level 1 CW 0 to 2000 hours	\$15.29	\$6.83	\$0.46	\$0.92	\$0.00	\$0.46	\$0.10	\$0.00	\$0.00	\$24.06	\$31.71
Level 2 CW 2001 to 4000 hours	\$16.25	\$6.83	\$0.49	\$0.92	\$0.00	\$0.49	\$0.10	\$0.00	\$0.00	\$25.08	\$33.21
Level 3 CW 4001 to 6000 hours	\$17.20	\$6.83	\$0.52	\$0.92	\$0.00	\$0.52	\$0.10	\$0.00	\$0.00	\$26.09	\$34.69
Level 4 CW 6001 to 8000 hours	\$19.12	\$6.83	\$0.57	\$0.92	\$0.00	\$0.57	\$0.10	\$0.00	\$0.00	\$28.11	\$37.67
Level 1 CE 8001 to 10000 hours	\$21.03	\$6.83	\$0.63	\$0.92	\$0.00	\$0.63	\$0.10	\$0.00	\$0.00	\$30.14	\$40.66
Level 2 CE 10,001 to 12,000 hours	\$22.94	\$6.83	\$0.69	\$0.92	\$0.00	\$0.69	\$0.10	\$0.00	\$0.00	\$32.17	\$43.64

		Fringe Benefit Payments						Irrevocable Fund		Total PWR	Overtime Rate
		H&W	Pension	App Tr.	Vac.	Annuity	Other	LECET (*)	MISC (*)		
Level 3 CE 12,001 to 14,000 hours	\$28.67	\$6.83	\$0.86	\$0.92	\$0.00	\$0.86	\$0.10	\$0.00	\$0.00	\$38.24	\$52.58
Apprentice	Percent	BHR									
0-1000 hrs 1st Period	50.000000	\$21.50	\$12.15	\$4.41	\$1.16	\$0.00	\$0.00	\$0.00	\$0.00	\$39.22	\$49.97
1001-2000 hrs 2nd Period	55.000000	\$23.65	\$12.15	\$4.85	\$1.16	\$0.00	\$0.00	\$0.00	\$0.00	\$41.81	\$53.63
2001-3500 hrs 3rd Period	60.000000	\$25.80	\$12.15	\$5.28	\$1.16	\$0.00	\$2.55	\$0.00	\$0.00	\$46.94	\$59.84
3501-5000 hrs 4th Period	65.000000	\$27.95	\$12.15	\$5.73	\$1.16	\$0.00	\$2.76	\$0.00	\$0.00	\$49.75	\$63.73
5001-6500 hrs 5th Period	70.000000	\$30.10	\$12.15	\$6.16	\$1.16	\$0.00	\$2.98	\$0.00	\$0.00	\$52.55	\$67.60
6501-8000 hrs 6th Period	80.000000	\$34.40	\$12.15	\$7.05	\$1.16	\$0.00	\$3.40	\$0.00	\$0.00	\$58.16	\$75.36

Special Calculation Note

Other for CW/CE: Education Fund

Ratio

1 to 3 Journeymen to 2 Apprentices
 4 to 6 Journeymen to 4 Apprentices

Construction Wireman and Construction Electrician Ratio:

1 Journeymen to 4 (CW/CE) Employees

An Inside Journeyman Wireman is required on the project at the 5th worker or when apprentices are used.

Jurisdiction (* denotes special jurisdictional note)

Champaign, Clark, Delaware, Fairfield, Franklin, Madison, Pickaway*, Union

Special Jurisdictional Note

In Pickaway County the following townships: Circleville, Darby, Harrison, Jackson, Madison, Monroe, Muhlenberg, Scioto, Walnut, Washington.

Details

The scope of work for the light commercial agreement shall apply to the following facilities not to exceed 200,000 square feet; office buildings, shopping centers, auto sales agencies and garages, churches, funeral homes, nursing homes, hotels, retail and wholesale facilities, small stand-alone manufacturing facilities when free standing and not part of a larger facility (not to exceed 50,000 square feet), solar projects (500 panels or less) unless otherwise covered under the agreement, lighting retrofits (when not associated with remodels involving branch re-circuiting) lighting retrofits shall be defined as the changing of lamps and ballasts in existing light fixtures and shall also include the one for one replacement of existing fixtures, warehouses, gas stations, food service centers, restaurants, entertainment facilities, hospitals, clinics, motels, residential buildings.

An Official State of Ohio site. [Here's how you know](#)

Prevailing Wage Rates - Skilled Crafts

Details

Union	Change#	Craft	Effective Date	Posted Date
Electrical Local 683 Inside	LCN02-2025ib	Electrical	08/13/2025	08/13/2025

Wage Rates

Classification	BHR	Fringe Benefit Payments						Irrevocable Fund		Total PWR	Overtime Rate
		H&W	Pension	App Tr.	Vac.	Annuity	Other	LECET (*)	MISC (*)		
Electrician	\$43.00	\$12.15	\$8.81	\$1.16	\$0.00	\$4.25	\$0.00	\$0.00	\$0.00	\$69.37	\$90.87
Welding	\$44.00	\$12.15	\$8.84	\$1.16	\$0.00	\$4.25	\$0.00	\$0.00	\$0.00	\$70.40	\$92.40
Medium Voltage Splicing	\$44.00	\$12.15	\$8.84	\$1.16	\$0.00	\$4.25	\$0.00	\$0.00	\$0.00	\$70.40	\$92.40
Over 100 feet	\$64.50	\$12.15	\$9.46	\$1.16	\$0.00	\$4.25	\$0.00	\$0.00	\$0.00	\$91.52	\$123.77
Level 1 CW 0 to 2000 hours	\$15.29	\$6.83	\$0.46	\$0.92	\$0.00	\$0.46	\$0.10	\$0.00	\$0.00	\$24.06	\$31.71
Level 2 CW 2001 to 4000 hours	\$16.25	\$6.83	\$0.49	\$0.92	\$0.00	\$0.49	\$0.10	\$0.00	\$0.00	\$25.08	\$33.21
Level 3 CW 4001 to 6000 hours	\$17.20	\$6.83	\$0.52	\$0.92	\$0.00	\$0.52	\$0.10	\$0.00	\$0.00	\$26.09	\$34.69
Level 4 CW 6001 to 8000 hours	\$19.12	\$6.83	\$0.57	\$0.92	\$0.00	\$0.57	\$0.10	\$0.00	\$0.00	\$28.11	\$37.67
Level 1 CE 8001 to 10000 hours	\$21.03	\$6.83	\$0.63	\$0.92	\$0.00	\$0.63	\$0.10	\$0.00	\$0.00	\$30.14	\$40.66
Level 2 CE 10,001 to 12,000 hours	\$22.94	\$6.83	\$0.69	\$0.92	\$0.00	\$0.69	\$0.10	\$0.00	\$0.00	\$32.17	\$43.64
Level 3 CE 12,001	\$28.67	\$6.83	\$0.86	\$0.92	\$0.00	\$0.86	\$0.10	\$0.00	\$0.00	\$38.24	\$52.58

			Fringe Benefit Payments						Irrevocable Fund		Total PWR	Overtime Rate
			H&W	Pension	App Tr.	Vac.	Annuity	Other	LECET (*)	MISC (*)		
to14,000 hours												
Apprentice	Percent	BHR										
0-1000 hrs 1st Period	50.000000	\$21.50	\$12.15	\$4.41	\$1.16	\$0.00	\$0.00	\$0.00	\$0.00	\$0.00	\$39.22	\$49.97
1001-2000 hrs 2nd Period	55.000000	\$23.65	\$12.15	\$4.85	\$1.16	\$0.00	\$0.00	\$0.00	\$0.00	\$0.00	\$41.81	\$53.63
2001-3500 hrs 3rd Period	60.000000	\$25.80	\$12.15	\$5.28	\$1.16	\$0.00	\$2.55	\$0.00	\$0.00	\$0.00	\$46.94	\$59.84
3501-5000 hrs 4th Period	65.000000	\$27.95	\$12.15	\$5.73	\$1.16	\$0.00	\$2.76	\$0.00	\$0.00	\$0.00	\$49.75	\$63.73
5001-6500 hrs 5th Period	70.000000	\$30.10	\$12.15	\$6.16	\$1.16	\$0.00	\$2.98	\$0.00	\$0.00	\$0.00	\$52.55	\$67.60
6501-8000 hrs 6th Period	80.000000	\$34.40	\$12.15	\$7.05	\$1.16	\$0.00	\$3.40	\$0.00	\$0.00	\$0.00	\$58.16	\$75.36

Special Calculation Note

Other for CW/CE: Education Fund

Ratio

1 to 3 Journeymen to 2 Apprentices
 4 to 6 Journeymen to 4 Apprentices

Construction Wireman and Construction Electrician Ratio:

1 Journeymen to 4 (CW/CE) Employees

An Inside Journeyman Wireman is required on the project at the 5th worker or when apprentices are used.

Jurisdiction (* denotes special jurisdictional note)

Champaign, Clark, Delaware, Fairfield, Franklin, Madison, Pickaway*, Union

Special Jurisdictional Note

In Pickaway County the following townships: Circleville, Darby, Harrison, Jackson, Madison, Monroe, Muhlenberg, Scioto, Walnut, Washington.

Details

Prevailing Wage Rate Skilled Crafts

Name of Union: Electrical Local 683 Voice Data Video

Change # : LCN01-2024ibLoc683VDV

Craft : Voice Data Video Effective Date : 06/26/2024 Last Posted : 06/26/2024

	BHR		Fringe Benefit Payments						Irrevocable Fund		Total PWR	Overtime Rate
			H&W	Pension	App Tr.	Vac.	Annuity	Other	LECET (*)	MISC (*)		
Classification												
Electrical Installer Technician B	\$30.00		\$9.77	\$3.65	\$0.80	\$0.00	\$3.00	\$0.69	\$0.00	\$0.00	\$47.91	\$62.91
Installer Technician A	\$31.25		\$9.77	\$3.69	\$0.80	\$0.00	\$3.00	\$0.72	\$0.00	\$0.00	\$49.23	\$64.85
Cable Puller	\$15.00		\$9.77	\$0.45	\$0.80	\$0.00	\$3.00	\$0.35	\$0.00	\$0.00	\$29.37	\$36.87
Apprentices												
	Percent											
1st Period 0-1000 hours	55.00	\$16.50	\$9.77	\$3.25	\$0.80	\$0.00	\$3.00	\$0.38	\$0.00	\$0.00	\$33.70	\$41.95
2nd Period 1001- 2000 hours	60.00	\$18.00	\$9.77	\$3.29	\$0.80	\$0.00	\$3.00	\$0.42	\$0.00	\$0.00	\$35.28	\$44.28
3rd Period 2001-3000 hours	65.00	\$19.50	\$9.77	\$3.34	\$0.80	\$0.00	\$3.00	\$0.45	\$0.00	\$0.00	\$36.86	\$46.61
4th Period 3001-4000 hours	70.00	\$21.00	\$9.77	\$3.38	\$0.80	\$0.00	\$3.00	\$0.49	\$0.00	\$0.00	\$38.44	\$48.94
5th Period 4001-5000	75.00	\$22.50	\$9.77	\$3.43	\$0.80	\$0.00	\$3.00	\$0.52	\$0.00	\$0.00	\$40.02	\$51.27

hours												
6th Period 5001-6000 hours	80.00	\$24.00	\$9.77	\$3.47	\$0.80	\$0.00	\$3.00	\$0.55	\$0.00	\$0.00	\$41.59	\$53.59

Special Calculation Note : Other is Holiday Pay. Vacation applies only to employees who work for one employer for a period of one year.

Ratio :
1 Apprentice for every 1 Installer Technician

Jurisdiction (* denotes special jurisdictional note) :
CHAMPAIGN, CLARK, DELAWARE, FAIRFIELD, FRANKLIN,
MADISON, PICKAWAY*, UNION

Cable Pullers can only be employed after an apprentice is employed on the job

Special Jurisdictional Note : In Pickaway County the following townships: Circleville, Darby, Harrison, Jackson, Madison, Monroe, Muhlenberg, Scioto, Walnut, Washington.

Details :
An employee who is required to wear an electronic device after hours will receive an additional 1.00 per hour for all hours worked.

HOLIDAYS: Memorial Day, 4th of July, Labor Day, Thanksgiving Day, Christmas Day, New Years Day.

The following work is EXCLUDED from the Teledata Technician work scope:

- Installation of computer systems in industrial applications such as assembly lines, robotics, computer controller manufacturing systems.
- Installation of conduit &/or raceways shall be installed by Inside Wireman . On sites where there is no Inside Wireman employed, the Teledata Technician may install raceway, or conduit not greater than 10 foot.
- Fire Alarm work is excluded on all new construction sites or wherever the fire alarm system is installed in conduit
- All HVAC control work.

TECHNICIAN (A) is a Technician B who holds a current Technician Certification from BICSI (Building Industry Consulting Service International, Inc.)

CABLE PULLERS are for the installation of cable from one termination point to another.

An Official State of Ohio site. [Here's how you know](#)

Prevailing Wage Rates - Skilled Crafts

Details

Union	Change#	Craft	Effective Date	Posted Date
Electrical Local 683 Voice Data Video	LCN01-2025ib	Electrical	08/13/2025	08/13/2025

Wage Rates

		Fringe Benefit Payments						Irrevocable Fund		Total PWR	Overtime Rate	
		H&W	Pension	App Tr.	Vac.	Annuity	Other	LECET (*)	MISC (*)			
Classification	BHR											
Electrical Installer Technician B	\$32.00	\$10.62	\$4.46	\$0.80	\$0.00	\$3.00	\$0.74	\$0.00	\$0.00	\$51.62	\$67.62	
Installer Technician A	\$33.50	\$10.62	\$4.51	\$0.80	\$0.00	\$3.00	\$0.77	\$0.00	\$0.00	\$53.20	\$69.95	
Cable Puller	\$16.00	\$10.62	\$0.48	\$0.80	\$0.00	\$3.00	\$0.37	\$0.00	\$0.00	\$31.27	\$39.27	
Apprentices	Percent	BHR										
1st Period 0 - 1000 hours	60.000000	\$19.20	\$10.62	\$4.08	\$0.80	\$0.00	\$3.00	\$0.44	\$0.00	\$0.00	\$38.14	\$47.74
2nd Period 1001 - 2000 hours	65.000000	\$20.80	\$10.62	\$4.12	\$0.80	\$0.00	\$3.00	\$0.48	\$0.00	\$0.00	\$39.82	\$50.22
3rd Period 2001 - 3000 hours	70.000000	\$22.40	\$10.62	\$4.17	\$0.80	\$0.00	\$3.00	\$0.52	\$0.00	\$0.00	\$41.51	\$52.71
4th Period 3001 - 4000 hours	75.000000	\$24.00	\$10.62	\$4.22	\$0.80	\$0.00	\$3.00	\$0.55	\$0.00	\$0.00	\$43.19	\$55.19
5th Period 4001 - 5000 hours	80.000000	\$25.60	\$10.62	\$4.27	\$0.80	\$0.00	\$3.00	\$0.59	\$0.00	\$0.00	\$44.88	\$57.68
6th Period 5001 - 6000 hours	85.000000	\$27.20	\$10.62	\$4.32	\$0.80	\$0.00	\$3.00	\$0.63	\$0.00	\$0.00	\$46.57	\$60.17

Special Calculation Note

Other is Holiday Pay

Ratio

1 Apprentice for every 1 Installer Technician

Cable Pullers can only be employed after an apprentice is employed on the job

Jurisdiction (* denotes special jurisdictional note)

Champaign, Clark, Delaware, Fairfield, Franklin, Madison, Pickaway*, Union

Special Jurisdictional Note

In Pickaway County the following townships: Circleville, Darby, Harrison, Jackson, Madison, Monroe, Muhlenberg, Scioto, Walnut, Washington.

Details

An employee who is required to wear an electronic device after hours will receive an additional 1.00 per hour for all hours worked.

HOLIDAYS: Memorial Day, 4th of July, Labor Day, Thanksgiving Day, Christmas Day, New Years Day.

The following work is EXCLUDED from the Teledata Technician work scope: - Installation of computer systems in industrial applications such as assembly lines, robotics, computer controller manufacturing systems. - Installation of conduit &/or raceways shall be installed by Inside Wireman . On sites where there is no Inside Wireman employed, the Teledata Technician may install raceway, or conduit not greater than 10 foot. - Fire Alarm work is excluded on all new construction sites or wherever the fire alarm system is installed in conduit - All HVAC control work. TECHNICIAN (A) is a Technician B who holds a current Technician Certification from BICSI (Building Industry Consulting Service International, Inc.)

CABLE PULLERS are for the installation of cable from one termination point to another.

Prevailing Wage Rate Skilled Crafts

Name of Union: Elevator Local 37

Change # : LCN01-2023ibLoc37

Craft : Elevator Effective Date : 01/01/2024 Last Posted : 12/27/2023

	BHR		Fringe Benefit Payments					Irrevocable Fund		Total PWR	Overtime Rate	
			H&W	Pension	App Tr.	Vac.	Annuity	Other	LECET (*)	MISC (*)		
Classification												
Elevator Mechanic	\$54.93		\$16.17	\$10.86	\$0.75	\$4.39	\$10.10	\$0.00	\$0.00	\$0.00	\$97.20	\$124.66
Helper	\$38.45		\$16.17	\$10.86	\$0.75	\$3.07	\$10.10	\$0.00	\$0.00	\$0.00	\$79.40	\$98.62
Apprentice	Percent											
Probationary Apprentice	50.01	\$27.47	\$0.00	\$0.00	\$0.00	\$1.64	\$0.00	\$0.00	\$0.00	\$0.00	\$29.11	\$42.85
1st Year	55.00	\$30.21	\$16.17	\$10.86	\$0.75	\$1.81	\$10.10	\$0.00	\$0.00	\$0.00	\$69.90	\$85.01
2nd Year	65.00	\$35.70	\$16.17	\$10.86	\$0.75	\$2.14	\$10.10	\$0.00	\$0.00	\$0.00	\$75.72	\$93.58
3rd Year	70.00	\$38.45	\$16.17	\$10.86	\$0.75	\$2.30	\$10.10	\$0.00	\$0.00	\$0.00	\$78.63	\$97.86
4th Year	80.00	\$43.94	\$16.17	\$10.86	\$0.75	\$2.63	\$10.10	\$0.00	\$0.00	\$0.00	\$84.45	\$106.43
Assistant Mechanic	80.00	\$43.94	\$16.17	\$10.86	\$0.75	\$3.51	\$10.10	\$0.00	\$0.00	\$0.00	\$85.33	\$107.31

Special Calculation Note :

Ratio :

- 1 Journeyman to 1 Apprentice**
- 1 Journeyman to 1 Helper**
- 1 Journeyman to 1 Assistant Mechanic**

Jurisdiction (* denotes special jurisdictional note) :

ATHENS, CHAMPAIGN, CLARK, DELAWARE, FAIRFIELD, FAYETTE, FRANKLIN, GALLIA, GUERNSEY, HOCKING, JACKSON, KNOX, LAWRENCE, LICKING, LOGAN, MADISON, MARION, MEIGS, MORGAN, MORROW, MUSKINGUM, NOBLE, PERRY, PICKAWAY, PIKE, ROSS, UNION, VINTON

Special Jurisdictional Note :

Details :

****Art. 10 Par. 2 Apprentice Work Qualifications:**

Par 2- The total number of Helpers and Apprentices employed shall not exceed the number of Mechanics on any one job, except on jobs where two teams or more are working, one extra Helper or Apprentice may be employed for the first two teams and an extra Helper or Apprentice for each additional three teams.

Further, the Company may use as many Helpers and Apprentices as best suits his convenience under the direction of a Mechanic in wrecking old plants and in handling and hoisting material, and on foundation work. When removing old and installing new cable on existing elevator installations, the Company may use two Helpers or Apprentices to one Mechanic.

Prevailing Wage Rate

Skilled Crafts

Name of Union: Glazier Local 372

Change # : LCN02-2024ibLoc372

Craft : Glazier Effective Date : 11/01/2024 Last Posted : 10/30/2024

	BHR		Fringe Benefit Payments					Irrevocable Fund		Total PWR	Overtime Rate	
			H&W	Pension	App Tr.	Vac.	Annuity	Other	LECET (*)	MISC (*)		
Classification												
Glazier	\$33.82		\$6.20	\$10.14	\$0.45	\$0.00	\$0.00	\$0.00	\$0.00	\$0.00	\$50.61	\$67.52
Apprentice	Percent											
1st Year	70.00	\$23.67	\$6.20	\$2.84	\$0.45	\$0.00	\$0.00	\$0.00	\$0.00	\$0.00	\$33.16	\$45.00
2nd Year	75.00	\$25.37	\$6.20	\$2.84	\$0.45	\$0.00	\$0.00	\$0.00	\$0.00	\$0.00	\$34.86	\$47.54
3rd Year	85.00	\$28.75	\$6.20	\$6.55	\$0.45	\$0.00	\$0.00	\$0.00	\$0.00	\$0.00	\$41.95	\$56.32
4th Year	95.00	\$32.13	\$6.20	\$6.55	\$0.45	\$0.00	\$0.00	\$0.00	\$0.00	\$0.00	\$45.33	\$61.39

Special Calculation Note : No special calculations for this skilled craft wage rate are required at this time.

Ratio :

1 Journeyman to 1 Apprentice

Jurisdiction (* denotes special jurisdictional note) :

DELAWARE, FAIRFIELD, FAYETTE*, FRANKLIN, HOCKING, JACKSON, KNOX, LICKING, MADISON, MARION, MORROW, MUSKINGUM, PERRY, PICKAWAY, PIKE, ROSS, UNION, VINTON

Special Jurisdictional Note : Fayette County - locations west of State Route 62 ONLY.

Details :

A premium of one dollar (\$1.00) per hour above regular hourly rate of pay shall be paid for each hour worked by every employee from any mechanical lift or scaffold, either suspended or supported including the Hex type scaffolding.

Prevailing Wage Rate Skilled Crafts

Name of Union: Ironworker Local 172

Change # : LCN01-2025ib

Craft : Ironworker Effective Date : 06/11/2025 Last Posted : 06/11/2025

	BHR		Fringe Benefit Payments					Irrevocable Fund		Total PWR	Overtime Rate	
			H&W	Pension	App Tr.	Vac.	Annuity	Other	LECET (*)			MISC (*)
Classification												
Ironworker	\$40.87		\$9.50	\$9.50	\$0.71	\$0.00	\$3.50	\$0.00	\$0.00	\$0.00	\$64.08	\$84.51
Rigger Welder Reinforcing Sheeter Fence Erector Machinery Mover	\$40.87		\$9.50	\$9.50	\$0.71	\$0.00	\$3.50	\$0.00	\$0.00	\$0.00	\$64.08	\$84.51
Apprentice												
	Percent											
1st Year 0-1500 Hours	70.00	\$28.61	\$9.50	\$9.50	\$0.71	\$0.00	\$3.50	\$0.00	\$0.00	\$0.00	\$51.82	\$66.12
2nd Year 1501-3000 Hours	80.00	\$32.70	\$9.50	\$9.50	\$0.71	\$0.00	\$3.50	\$0.00	\$0.00	\$0.00	\$55.91	\$72.25
3rd Year 3001-4500 Hours	90.02	\$36.79	\$9.50	\$9.50	\$0.71	\$0.00	\$3.50	\$0.00	\$0.00	\$0.00	\$60.00	\$78.40

Special Calculation Note :

Ratio :

1 Journeyman to 1 Apprentice

Jurisdiction (* denotes special jurisdictional note) :

CHAMPAIGN*, CLARK*, CRAWFORD*, DELAWARE, FAIRFIELD, FAYETTE*, FRANKLIN, HARDIN*, HIGHLAND*, HOCKING, JACKSON*, KNOX, LICKING, LOGAN*, MADISON*, MARION, MORROW, PERRY, PICKAWAY, PIKE, ROSS, UNION, VINTON, WYANDOT*

Special Jurisdictional Note : Champaign County Twps included: Wayne, Rush, Goshen.
 Clark County Twps included: Vienna, Catawba and portions of Harmony and Pleasant
 Crawford County Twps included: Bucyrus, Dallas, Jefferson, Jackson, Whetstone, Polk, Sandusky.
 Fayette County Twps included: Paint, Marion, Perry, Madison, Wayne, Union.
 Hardin County Twps included: McDonald, Taylorcreek, Hale, Dudley, Pleasant, Goshen, Blanchard, Lynn, Jackson, Buck, Cessna, Marion, Washington.
 Highland County Twps included: Madison.
 Jackson County Twps included: Liberty, Washington, Milton, Jackson, Coal, Wilkesville.
 Logan County Twps included: Monroe, Zane, Jefferson, Perry, Rush Creek, Bokes Creek.
 Madison County Twps included: Range, Paint, Fairfield, Sommerford, Jefferson, Pike, Canaan, Pleasant, Oak Run, Union, Deer Creek, Monroe, Darby.
 Pike County Twps included: Perry, Benton, Mifflin, Sunfish, Newton, Prebble, Pee Pee, Seal, Beaver, Jackson.
 Wyandot County Twps included: Jackson, Marseilles, Mifflin, Pitt, Antrim.
 Muskingum County includes: Jackson, Licking, Hope Well, Newton, Clay, Cass, Muskingum falls, Springfield, Madison, Washington, Wayne, Brush Creek.

Details :

Prevailing Wage Rate Skilled Crafts

Name of Union: Labor HevHwy 3

Change # : LCN02-2025ib

Craft : Laborer Group 1 Effective Date : 06/11/2025 Last Posted : 06/11/2025

	BHR		Fringe Benefit Payments					Irrevocable Fund		Total PWR	Overtime Rate	
			H&W	Pension	App Tr.	Vac.	Annuity	Other	LECET (*)			MISC (*)
Classification												
Laborer Group 1	\$37.27		\$8.60	\$4.45	\$0.45	\$0.00	\$2.50	\$0.00	\$0.10	\$0.00	\$53.37	\$72.00
Group 2	\$37.44		\$8.60	\$4.45	\$0.45	\$0.00	\$2.50	\$0.00	\$0.10	\$0.00	\$53.54	\$72.26
Group 3	\$37.77		\$8.60	\$4.45	\$0.45	\$0.00	\$2.50	\$0.00	\$0.10	\$0.00	\$53.87	\$72.75
Group 4	\$38.22		\$8.60	\$4.45	\$0.45	\$0.00	\$2.50	\$0.00	\$0.10	\$0.00	\$54.32	\$73.43
Watch Person	\$32.00		\$8.60	\$4.45	\$0.45	\$0.00	\$2.50	\$0.00	\$0.10	\$0.00	\$48.10	\$64.10
Apprentice	Percent											
0-1000 hrs	80.00	\$29.82	\$8.60	\$4.45	\$0.45	\$0.00	\$2.50	\$0.00	\$0.10	\$0.00	\$45.92	\$60.82
1001-2000 hrs	85.00	\$31.68	\$8.60	\$4.45	\$0.45	\$0.00	\$2.50	\$0.00	\$0.10	\$0.00	\$47.78	\$63.62
2001-3000 hrs	90.00	\$33.54	\$8.60	\$4.45	\$0.45	\$0.00	\$2.50	\$0.00	\$0.10	\$0.00	\$49.64	\$66.41
3001-4000 hrs	95.00	\$35.41	\$8.60	\$4.45	\$0.45	\$0.00	\$2.50	\$0.00	\$0.10	\$0.00	\$51.51	\$69.21
More than 4000 hrs	100.00	\$37.27	\$8.60	\$4.45	\$0.45	\$0.00	\$2.50	\$0.00	\$0.10	\$0.00	\$53.37	\$72.00

Special Calculation Note : Watchmen have no Apprentices. Tunnel Laborer rate with air-pressurized add \$1.00 to the above wage rate.

Commercial Driver’s License – Any Laborer required to utilize a valid Commercial Driver’s License (CDL), are in compliance with necessary FMCSA regulations and approved by the Contractor to operate a Commercial Motor Vehicle (CMV), shall be paid one dollar (\$1.00) per hour above the base rate for the entirety of their working shift.

Ratio :

- 1 Journeymen to 1 Apprentice
- 3 Journeymen to 1 Apprentice thereafter

Jurisdiction (* denotes special jurisdictional note) :

ADAMS, ALLEN, ASHLAND, ATHENS, AUGLAIZE, BELMONT, BROWN, BUTLER, CARROLL, CHAMPAIGN, CLARK, CLERMONT, CLINTON, COLUMBIANA, COSHOCTON, CRAWFORD, DARKE, DEFIANCE, DELAWARE, FAIRFIELD, FAYETTE, FRANKLIN, FULTON, GALLIA, GREENE, GUERNSEY, HAMILTON, HANCOCK, HARDIN, HARRISON, HENRY, HIGHLAND, HOCKING, HOLMES, JACKSON, JEFFERSON, KNOX, LAWRENCE, LICKING, LOGAN, MADISON, MARION, MEIGS, MERCER, MIAMI, MONROE, MONTGOMERY, MORGAN, MORROW, MUSKINGUM, NOBLE, PAULDING, PERRY, PICKAWAY, PIKE, PREBLE, PUTNAM, RICHLAND, ROSS, SCIOTO, SENECA, SHELBY, TUSCARAWAS, UNION, VAN WERT, VINTON, WARREN, WASHINGTON, WAYNE, WILLIAMS, WYANDOT

Special Jurisdictional Note : Hod Carriers and Common Laborers - Heavy, Highway, Sewer, Waterworks, Utility, Airport, Railroad, Industrial and Building Site, Sewer Plant, Waste Water Treatment Facilities Construction

Details :**Group 1**

Laborer (Construction); Plant Laborer or Yardman, Right-of-way Laborer, Landscape Laborer, Highway Lighting Worker, Signalization Worker, (Swimming) Pool Construction Laborer, Utility Man, *Bridge Man, Handyman, Joint Setter, Flagperson, Carpenter Helper, Waterproofing Laborer, Slurry Seal, Seal Coating, Surface Treatment or Road Mix Laborer, Riprap Laborer & Grouter, Asphalt Laborer, Dump Man (batch trucks), Guardrail & Fence Installer, Mesh Handler & Placer, Concrete Curing Applicator, Scaffold Erector, Sign Installer, Hazardous Waste (level D), Diver Helper, Zone Person and Traffic Control.

*Bridge Man will perform work as per the October 31, 1949, memorandum on concrete forms, by and between the United Brotherhood of Carpenters and Joiners of America and the Laborers' International Union of North America, which states in; "the moving, cleaning, oiling and carrying to the next point of erection, and the stripping of forms which are not to be re-used, and forms on all flat arch work shall be done by members of the Laborers' International Union of North America."

Group 2

Asphalt Raker, Screwman or Paver, Concrete Puddler, Kettle Man (pipeline), All Machine-Driven Tools (Gas, Electric, Air), Mason Tender, Brick Paver, Mortar Mixer, Skid Steer, Sheeting & Shoring Person, Surface Grinder Person, Screedperson, Water Blast, Hand Held Wand, Power Buggy or Power Wheelbarrow, Paint Striper, Plastic fusing Machine Operator, Rodding Machine Operator, Pug Mill Operator, Operator of All Vacuum Devices Wet or Dry, Handling of all Pumps 4 inches and under (gas, air or electric), Diver, Form Setter, Bottom Person, Welder Helper (pipeline), Concrete Saw Person, Cutting with Burning Torch, Pipe Layer, Hand Spiker (railroad), Underground Person (working in sewer and waterline, cleaning, repairing and reconditioning). Tunnel Laborer (without air), Caisson, Cofferdam (below 25 feet deep), Air Track and Wagon Drill, Sandblaster Nozzle Person, Hazardous Waste (level B), ***Lead Abatement, Hazardous Waste (level C)

***Includes the erecting of structures for the removal, including the encapsulation and containment of Lead abatement process.

Group 3

Blast and Powder Person, Muckers will be defined as shovel men working directly with the miners, Wrencher (mechanical joints & utility pipeline), Yarnier, Top Lander, Hazardous Waste (level A), Concrete Specialist, Curb Setter and Cutter, Grade Checker, Concrete Crew in Tunnels. Utility pipeline Tappers, Waterline, Caulker, Signal Person will receive the rate equal to the rate paid the Laborer classification for which the Laborer is signaling.

Group 4

Miner, Welder, Gunitite Nozzle Person

A.) The Watchperson shall be responsible to patrol and maintain a safe traffic zone including but not limited to barrels, cones, signs, arrow boards, message boards etc.

The responsibility of a watchperson is to see that the equipment, job and office trailer etc. are secure.

Prevailing Wage Rate Skilled Crafts

Name of Union: Labor Local 423

Change # : LCN01-2025ibLoc423

Craft : Laborer Effective Date : 06/01/2025 Last Posted : 05/28/2025

	BHR		Fringe Benefit Payments					Irrevocable Fund		Total PWR	Overtime Rate	
			H&W	Pension	App Tr.	Vac.	Annuity	Other	LECET (*)			MISC (*)
Classification												
Laborer Group 1	\$32.98		\$8.60	\$4.45	\$0.40	\$0.00	\$1.00	\$0.00	\$0.10	\$0.00	\$47.53	\$64.02
Group 2	\$33.29		\$8.60	\$4.45	\$0.40	\$0.00	\$1.00	\$0.00	\$0.10	\$0.00	\$47.84	\$64.48
Group 3	\$33.60		\$8.60	\$4.45	\$0.40	\$0.00	\$1.00	\$0.00	\$0.10	\$0.00	\$48.15	\$64.95
Group 4	\$33.91		\$8.60	\$4.45	\$0.40	\$0.00	\$1.00	\$0.00	\$0.10	\$0.00	\$48.46	\$65.41
Apprentice	Percent											
0-1000 hrs	70.00	\$23.09	\$8.60	\$4.45	\$0.40	\$0.00	\$1.00	\$0.00	\$0.10	\$0.00	\$37.64	\$49.18
1001-2000 hrs	80.00	\$26.38	\$8.60	\$4.45	\$0.40	\$0.00	\$1.00	\$0.00	\$0.10	\$0.00	\$40.93	\$54.13
2001-3000 hrs	90.00	\$29.68	\$8.60	\$4.45	\$0.40	\$0.00	\$1.00	\$0.00	\$0.10	\$0.00	\$44.23	\$59.07
3001-4000 hrs	95.00	\$31.33	\$8.60	\$4.45	\$0.40	\$0.00	\$1.00	\$0.00	\$0.10	\$0.00	\$45.88	\$61.55
More than 4000 hrs	100.00	\$32.98	\$8.60	\$4.45	\$0.40	\$0.00	\$1.00	\$0.00	\$0.10	\$0.00	\$47.53	\$64.02

Special Calculation Note :

Ratio :

1 Journeymen to 1 Apprentice
4 Journeymen to 1 Apprentice

Jurisdiction (* denotes special jurisdictional note) :

FAIRFIELD, FAYETTE, FRANKLIN, HOCKING, LICKING, MADISON, PICKAWAY, UNION

Special Jurisdictional Note :

Details :

Group 1:

General Laborers, Carpenter Tender, Cathodic Protection, Cleaning Debris, Cleaning of all Material, General Clean-up including Vacuum Cleaning, Scraping and Cleaning of Walls and Floors, Landscape, Installation and Removal of Fencing, Sod Layers, All Portable Heaters, Flagman, Loading and Unloading of all Trucks, Handling and conveying all Materials, Washing of all Windows, Conveyer Belt, All Water Pumps up to and including three (3) inch intake, Watchman, Water Boy and Tool Room Attendant.

Group 1- Swimming Pools, Pool Decks, Surrounding Sidewalk and Parking Garages.

Group 2:

Skid Steer, Concrete Specialists, Brick Tender, Stone Mason Tender, Plaster Tender, Mortar Mixer and Operator, Cement Mason Tender, Construction Specialist, All Scaffold Builders (Swinging Scaffolds), Lagging, Bush Hammering, Jack Hammer Operator, Air or Electric Pneumatic Tool Operator, Power Driven Tools, Power Buggy Operators, Pouring and Placement of all concrete, Fork Lift Operators, Power Wheelbarrow Operators, Asphalt and Blacktop Rakers, Wrecker/Demolition, Sand Blasting and Chipping, Welders on Demolition, Grade Checkers, a person on a bucket pouring concrete, Guniting Nozzle man, Wagon and Churn Drill Operator, Concrete Saw Operator, Brush Feeders on pulverizers, Pipe Layers, Bottom Man, Laser Gun, Burners, Sand Blasting of concrete, Vibrator Man, Steward, Signal Man, Caisson, Caisson Bottom Man, Piledrivers, Asbestos and Lead Abatement Laborers.

Hazardous Waste (Level B): Any work requiring the following protective equipment must be paid at Group 2 rate,

A protective suit and an Air Purifying Respirator (APR) with the appropriate filter canisters. The ensemble is used when contaminants are reliably known not to be hazardous to the skin and not IDLH (Immediately Dangerous To Life or Health) and correct filter protection is available. This ensemble offers adequate protection for many jobs. Heat stress may be a problem due to inherent restrictions to breathing in an APR. Also, normal

job related injury risk will be nearly as high as for Level C Equipment.

Group 3 Hazardous (Level C:) Any work requiring the following protective equipment must be paid at Group 3 rate,

A chemically resistant splash suit and a (SCBA) or Airline Respirator. This ensemble is required when the situation is very hazardous, such as oxygen deficient atmospheres, IDLH atmospheres, or confined space entries, but the risk of skin exposure is not as great as in Level D situations. Then Level C ensemble gives the second highest level of protection, but also puts physical stress on the worker; primarily heat stress, reduced vision, dexterity and mobility directly attributable to wearing of the protective equipment. Therefore, in addition to the hazardous material, the hazard of the normal job related injuries is greatly increased.

Group 4 Hazardous Waste (Level D) requiring the following protective equipment must be paid at Group 4 rate, Protective equipment is required when the area has been known to contain extremely toxic contaminants or contaminants unknown but may be expected to be extremely toxic and /or Immediately Dangerous to Life and Health (IDLH). This ensemble includes fully encapsulated chemical suit (moon suit), Self Contained Breathing Apparatus (SCBA), or Airline Fed Respirator, and various types and numbers of boots and gloves, cool vests and voice activated radios are optional equipment sometimes worn. Level D ensembles provide the highest level of protection from contaminants but places the greatest physical and mental stress on the worker. The claustrophobic environment of the moon suit causes anxiety in most people, which greatly increases the already inherent heat stress problems. Also, this ensemble reduces vision, mobility, dexterity, and communication capacity, all of which increases the risk of normal job related injuries, ie., slips ,falls, caught between, etc

Hazardous Pay of \$0.25 per hour shall be paid in addition to classifications shown above

Swing Scaffolds (suspended by rope or pulley), and swing scaffolds for grain storage tank or grain elevators, when the work is performed at a height of fifty (50) feet or more above the foundations or grade level, whichever is higher. Caisson work and tunnel work (depth being 15 feet or deeper)

Hazardous Waste Removal & Lead Abatement Workers: Exclusive or "Hot" area with toxic or hazardous materials, when one of the following personal protective equipment ensembles will be required for necessary protection against toxic contaminants. All of the ensembles increase the risks of certain types of worker-related injuries. When Laborers complement another craft receiving premium rate of pay Laborers will also receive premium pay for this "HOT" type of work.